



Nitsch Engineering

April 6, 2022
Revised July 6, 2022

**STORMWATER
REPORT**

For

**EAST BEACH PARKING LOT
GREEN INFRASTRUCTURE RERTOFIT**
New Bedford, Massachusetts

Prepared for:

**CITY OF NEW BEDFORD
PARKS RECREATION & BEACHES**
181 Hillman Street, Building 3
New Bedford, MA 02740

Prepared by:

NITSCH ENGINEERING, INC.
2 Center Plaza, Suite 430
Boston, MA 02108

Nitsch Project #14850

NITSCH PROJECT #14850

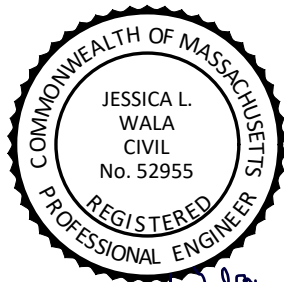

Jessica L. Wala
7/6/2022

TABLE OF CONTENTS

1.0	INTRODUCTION	1
2.0	EXISTING CONDITIONS.....	2
2.1	NRSC Soil Designations	3
2.2	On-Site Soil Investigations	3
2.3	Wetland Resource Areas	5
2.4	Total Maximum Daily Load (TMDL).....	5
3.0	NEW BEDFORD STORMWATER MANAGEMENT STANDARDS	6
4.0	PROPOSED CONDITIONS	7
4.1	Project Description.....	7
4.2	Proposed Green Infrastructure Improvements	8
4.3	Stormwater Management During Construction.....	10
5.0	STORMWATER MANAGEMENT ANALYSIS	11
5.1	Methodology	11
5.2	HydroCAD Version 10.00.....	11
6.0	WATER QUALITY VOLUME CALCULATIONS	11
7.0	MASSDEP STORMWATER MANAGEMENT STANDARDS	12
	Standard 1: No New Untreated Discharges.....	12
	Standard 2: Peak Rate Attenuation	13
	Standard 3: Groundwater Recharge.....	13
	Standard 4: Water Quality Treatment.....	13
	Standard 5: Land Uses with Higher Potential Pollutant Loads (LUHPPL).....	15
	Standard 6: Critical Areas	15
	Standard 7: Redevelopments.....	15

Standard 8: Construction Period Pollution Prevention and Sedimentation Control 15

Standard 9: Operation and Maintenance Plan..... 15

Standard 10: Prohibition of Illicit Discharges 15

8.0 CONCLUSION.....16

FIGURES

- DR-1A Existing Watershed Areas (30 Scale)
- DR-1B Existing Watershed Areas (100 Scale)
- DR-2A Proposed Watershed Areas (30 Scale)
- DR-2B Proposed Watershed Areas (100 Scale)

UPDATED 7/6/2022 TO
INCLUDE SEDIMENT
FOREBAY TRIBUTARY
AREA

APPENDICES

Appendix A Stormwater Management Standards Documentation

- MassDEP Checklist for Stormwater Report
- Standard 4: TSS Removal Calculations
- Phosphorous Removal Calculations
- Standard 4: Isolator Row Sizing Calculations
- Standard 10: Illicit Discharge Compliance Statement

Appendix B HydroCAD Calculations – Water Quality Storm (1.7-inch)

Appendix C HydroCAD – Existing Peak Runoff Rates

Appendix D HydroCAD – Proposed Peak Runoff Rates

**Appendix E Long-Term Pollution Prevention and Stormwater Operation and
Maintenance Plan**

Appendix F Soil Investigations

- NRCS Soil Maps and Descriptions
- Test Pit Information

UPDATED 7/6/2022 TO
INCLUDE LICENSED SOIL
EVALUATOR NUMBER

1.0 INTRODUCTION

Nitsch Engineering has prepared this Stormwater Report to support the Notice of Intent (NOI) to the New Bedford Conservation Commission for the proposed East Beach Parking Lot Green Infrastructure Retrofit project within the East Beach parking lots, which are located within jurisdictional wetland resource areas (subsequently referred to as the “Project”).

The Site consists of three (3) separate parking lots located along Rodney French Boulevard East. The improvements include reconstructing and greening the existing parking lot and providing water quality treatment through bioretention basins and subsurface infiltration systems.

The Project limit of work includes the following parcels:

- Parking Lot A: Map 4, Lot 100
- Parking Lot B: Map 4, Lot 101
- Parking Lot C: Map 4, Lot 102



Figure 1. Site Locus

The proposed stormwater improvements have been designed to comply with the requirements of the City of New Bedford Stormwater Management Rules & Regulations (New Bedford Stormwater Regulations) and the Massachusetts Department of Environmental Protection (DEP) Stormwater Management Standards. The Project has also been designed to meet the City of New Bedford Green Infrastructure Plan water quality volume goal, which exceeds the requirements put forth in the New Bedford Stormwater Regulations, per the direction of the Department of Public Infrastructure (DPI).

2.0 EXISTING CONDITIONS

The Project site consists of three (3) existing parking lots along Rodney French Boulevard East. The existing parking lots are entirely paved and are in poor surface condition. (Figure 1 – USGS Locus Map and Figure 2 – Aerial Locus Map).

- Parking Lot A:
 - 0.74 Acres
 - Bound by Rodney French Boulevard South to the south, Rodney French Boulevard East to the east, and Seymour Street to the north.
 - Flows to existing catch basins within Rodney French Boulevard South and Seymour Street.
- Parking Lot B:
 - 0.95 Acres
 - Bound by Seymour Street to the south, Rodney French Boulevard East to the east, and Hudson Street to the north.
 - Flows to existing catch basins within Seymour Street and Hudson Street.
- Parking Lot C:
 - 1.05 Acres
 - Bound by Hudson Street to the south, Rodney French Boulevard East to the east, and Portland Street to the north.
 - Flows to existing catch basin within Hudson Street and Portland Street.

There is no existing stormwater collection or treatment systems within the parking lots. There is an existing drain pipe and sewer pipe that run through Parking Lot A; however the parking lot does not appear to discharge to either pipe. These existing pipes will be maintained as part of the Project.

Stormwater runoff in Seymour Street, Rodney French Boulevard South, and the adjacent portion of East Rodney French Boulevard East is collected by a series of catch basins that flow west in East Rodney French Boulevard and connect to an existing 14-inch drain main which flows and outlets to the harbor via an outfall.

Stormwater runoff from Hudson Street, Portland Street, and the northern portion of East Rodney French Boulevard is collected by a closed drainage system which flows north and connects to a 15-inch storm drain main which outfalls to the harbor.



Figure 2: Existing Drainage Infrastructure

2.1 NRCS Soil Designations

The Soil Classification Summary (Table 1) outlines the Natural Resources Conservation Services (NRCS) designation of the soil series at the Site. The Site is located within urban land, which does not have a hydrologic soil rating (refer to the NRCS Soil Maps and Descriptions in Appendix E).

Table 1. NRCS Soil Classification Summary

Soil Unit	Soil Series	Hydrologic Soil Group
602	Urban Land	-

2.2 On-Site Soil Investigations

Nitsch Engineering, Inc. performed nine (9) test pits at the Site on 2/24/2022 and 3/3/2022. Site Evaluations were performed by Brian Biagini, EIT– Licensed Soil Evaluator Number 14419.

Three (3) test pits were performed within each parking lot. The eastern test pits, along Rodney French Boulevard East, encountered evidence of groundwater at depths ranging from 58-inches to 83-inches

below grade. The western test pits on the uphill side of the parking lots encountered groundwater depths ranging from 78-inches to 90-inches. Based on the test pits, Nitsch Engineering determined that infiltration is feasible at the up-hill portions of the parking lots (western), where a minimum of 2-ft groundwater separation can be achieved.

Based on the sandy loam conditions encountered at the approximately bottom of BMP elevations, the Project assumed a Rawls Rate of 1.02 inches/hour, associated with the texture class Sandy Loam.

Table 2. Test Pit Summary

Test Pit #	Soil Type	Groundwater Depth (inches)	Surface Elevation at Test Pit Location	Groundwater Elevation
1 [Lot A]	Sandy Loam	58	9.7	4.9
2 [Lot A]	Sandy Loam	72	10.4	4.4
3 [Lot B]	Sandy Loam	64	10.4	5.0
4 [Lot B]	Sandy Loam	64	10	4.7
5 [Lot C]	Sandy Loam	56	10	5.3
6 [Lot C]	Sandy Loam	83	9.7	2.8
7 [Lot A]	Sandy Loam	90	12	4.5
8 [Lot B]	Sandy Loam	85	11.5	4.4
9 [Lot C]	Sandy Loam	78	11.8	5.3



Figure 3: Test Pit Locations

2.3 Wetland Resource Areas

The Project site is bordered by residential parcels and public roadways and is located within Land Subject to Coastal Storm Flowage (LSCSF). The Project site is also located within the 100-foot Buffer Zone associated with the nearby coastal resource areas (i.e. the coastal beach). Refer to the Notice of Intent for additional information regarding the resource areas.

2.4 Total Maximum Daily Load (TMDL)

The sub-watershed has been identified as impaired/threatened per the Outer New Bedford Harbor, Category 5 (Impaired or threatened for one or more uses and requiring a TMDL). See Table 3 for a list of impairments.

Table 3. List of Impairments for Outer New Bedford Harbor

Water Body	Classification	Impairment(s)
Outer New Bedford Harbor (MA95-63_2008)	Category 5: Impaired or threatened for one or more uses and requiring a TMDL.	Metals Nonpriority organics Nutrients Organic enrichment/Low DO Pathogens Priority organics

The Site does not have stormwater treatment prior to discharge in the existing conditions. The proposed green infrastructure improvements are designed specifically to improve stormwater quality. The Project has been designed to reduce stormwater discharge and associated pathogen pollutants through filtration and infiltration to meet the intent of the TMDL.

3.0 NEW BEDFORD STORMWATER MANAGEMENT STANDARDS

The City of New Bedford requires stormwater management systems on redevelopment sites be designed to meet an average annual pollutant removal equivalent to:

- 80% of the average annual postconstruction load of Total Suspended Solids (TSS) related to the total postconstruction impervious area on the site, and
- 50% of the average annual load of Total Phosphorus (TP) related to the total post-construction impervious surface area on the site.

This treatment shall be achieved by retaining the volume of runoff equivalent to, or greater than, 0.8 inch multiplied by the total post-construction impervious surface area on the redeveloped site or meeting a combination of retention and treatment that achieves the above standards.

City of New Bedford Green Infrastructure Plan:

Nitsch Engineering understands that the City is in the process of developing and adopting a new city-wide green infrastructure strategy (the Green Infrastructure Master Strategy and Implementation Roadmap). Per coordination with the DPI, DPI indicated that the Project should align with the goal of this new plan, which will have a water quality treatment goal of 1.7-inches over the impervious area. This goal significantly exceeds state and local stormwater standards.

4.0 PROPOSED CONDITIONS

4.1 Project Description

The Project consists of the construction of new Best Management Practices (BMPs) that have been designed in accordance with the MassDEP Stormwater Management Standards and the City of New Bedford Stormwater Management Regulations. The systems are designed to provide water quality treatment prior to discharge to the existing drainage system, improving the water quality discharging to the Outer New Bedford Harbor. A summary of these improvements is provided below.

The Project will result in a net reduction in impervious area of 0.29 acres of impervious area (Table 4).

Table 4. Existing and proposed land cover

Land Use	Existing (acres)	Proposed (acres)	Change
Impervious Area	2.74	2.45	- 0.29
Landscape/Gravel Area	--	0.29	+ 0.29
Total	2.74	2.74	--

The Project includes the construction of bioretention basins designed to treat contributing impervious areas within the parking lot and the upstream residential parcels which flow overland into the parking lots. Where the bioretention basins cannot be sized to meet the full 1.7-inch water quality volume goal from the City of New Bedford Green Infrastructure Plan, the remaining runoff from the water quality volume will be directed to subgrade isolator rows to provide the remaining treatment prior to discharging to the City storm drain mains.

In addition, the Project will divert runoff from the adjacent Seymour Street, Hudson Street and Portland Street and direct runoff into the subsurface treatment and infiltration system located below the parking lots. The infiltration systems are sized to infiltrate the 1.7-inch water quality storm and bypass/overflow the larger storms.

The off-site contributing drainage areas are summarized below. See Figure DA-1 for a summary of the off-site contributing drainage areas.

Table 5. Contributing Watershed Areas (acres)

Land Use	Area (acres)
Roadways (Hudson, Seymour, Portland St)	0.86
Residential Parcels (38% Impervious) ^A	4.94
Total Contributing Watershed Area	5.80 ^B

A) The % imperviousness of the residential portions is calculated based on the Curve Number associated with 1/4 acre residential lots - see HydroCAD methodology for more information on the Curve Number calculations.

B) Does not include the Parking Lots

Overflow from the new stormwater management systems will discharge to the new closed drainage systems within the parking lots, which will connect to the existing city storm drain mains in Rodney French Boulevard East, which are described in Section 2.0.

4.2 Proposed Green Infrastructure Improvements

The Project includes the installation of green infrastructure stormwater improvements that have been designed to meet the MassDEP Stormwater Management Standards and City of New Bedford Stormwater Management Rules & Regulations. The Project is focused on improving the existing stormwater system by implementing environmentally-sensitive site design and LID techniques. This design prevents the generation of stormwater and non-point source pollution by reducing impervious surfaces with landscaping and permeable materials, disconnecting flow paths, treating and infiltrating stormwater at its source, and protecting natural processes. Stormwater systems have been designed to model natural hydrologic features, including promoting infiltration throughout the sites.

The proposed stormwater management system for the Project includes bioretention basins, isolator rows and subsurface infiltration systems. These system components are described below. Overflow from the proposed improvements will reconnect to the existing stormwater system and associated outfalls.

<p style="text-align: center;"><u>Treatment Train A</u> <u>Infiltrating Bioretention Basin</u> [BB#3A, BB#3B, BB#6B] Parking Lot Runoff + Contributing Residential Parcels → Sediment Forebay → Bioretention Basin</p> <p style="text-align: center;"><u>Treatment Train B</u> <u>Lined Biofiltration Basin</u> [BB#2A, BB#4A, BB#4B, BB#5A, BB#6A, BB#7A, BB#7B, BB#8A, BB#8B] Parking Lot Runoff + Contributing Residential Parcels → Biofiltration Basin</p> <p style="text-align: center;"><u>Treatment Train C</u> <u>Bioretention Basin, overflow to Isolator Rows</u> [BB#1, BB#2B, BB#5B, BB#9] Parking Lot Runoff + Contributing Residential Parcels → Bioretention Basin → Overflow to Isolator Row</p> <p style="text-align: center;"><u>Treatment Train D</u> <u>Upstream Watershed to Infiltration System</u> [CB1, CB3, CB4, CB5] Roadway and Residential Runoff → Isolator Row → Infiltration System</p>

Deep Sump and Hooded Catch Basins

Deep sump and hooded catch basins are proposed to provide pretreatment of the runoff from the roadways prior to discharging to the infiltration systems. Stormwater captured in the catch basins will be directed to additional pretreatment and then to the subsurface infiltration systems prior to discharge.

Subsurface Infiltration/Detention Systems

Stormwater runoff from the adjacent roadways will be collected and infiltrated using a subsurface infiltration system in each parking lot. The upstream diversion manhole will direct stormwater runoff from approximately the 1.7-inch storm event to the subsurface infiltration systems and bypass the larger storm events to the maximum extent practicable. The Isolator Rows will treat for phosphorous

and TSS. The systems are designed to, at minimum, infiltrate the 1.7-inch storm event water quality volume, and because of the added storage volume will reduce peak runoff rates in the larger storms. The larger storm events will overflow to the new closed drainage systems within the parking lots.

Roadway runoff that is tributary to these systems will be pretreated using deep sump and hooded catch basins and isolator rows to meet the 44% TSS removal prior to infiltration.

Subsurface Infiltration System #1 is proposed to collect runoff from the southern portion of Seymour Street. The system consists of StormTech SC-310 chambers enveloped by crushed stone.

Subsurface Infiltration System #2 is proposed to collect runoff from Hudson Street. The system consists of StormTech SC-370 chambers enveloped by crushed stone.

Subsurface Infiltration System #3 is proposed to collect runoff from the southern portion of Portland Street. The system consists of StormTech SC-310 chambers enveloped by crushed stone.

Infiltrating Bioretention Basins with Sediment Forebay

Bioretention basins are proposed to treat stormwater runoff from the parking lots and the residential areas from which runoff overland flows directly to the parking lots. Where groundwater separation can be achieved, the bioretention basins will be infiltrating (Bioretention Basins: BB#3A, BB#3B, BB#6B). Stormwater runoff will be treated as it flows through the bioretention soil media and the filter course layers, before reaching the crushed stone reservoir which will promote storage and infiltration into the subgrade.

The bioretention basins are sized to store and infiltrate the stormwater volume of 1.7-inches over the contributing impervious area. Overflow from larger storm events will be collected via overflow area drains within the basins that discharge to the new closed drainage system within the parking lots.

Pretreatment for the bioretention basin will be provided sediment forebays. The sediment forebays are designed in accordance with the MassDEP Stormwater Management Handbook to provide a water quality volume (WQV) equivalent to 0.1 inches per impervious acre.

Lined Bioretention Basins

Where groundwater separation **cannot** be achieved, the bioretention basins will be designed to treat stormwater runoff as it flows through the bioretention soil media and the filter course layers, before reaching the underdrain within the crushed stone reservoir which will connect to the new closed drainage system within the parking lots.

The bioretention basins are sized to store and filter the stormwater volume of 1.7-inches over the contributing impervious area through the bioretention basin section. Overflow from larger storm events will be collected via overflow area drains within the basins that discharge to the new closed drainage system within the parking lots.

Isolator Rows

The Isolator Rows consist of plastic chambers, wrapped in a geotextile fabric within a crushed stone reservoir. Runoff slowly passes from the chambers through a woven geotextile fabric and into the crushed stone reservoir below the system. The runoff passes through the fabric, leaving behind sediments and associated contaminants through the physical unit operations of filtration and sedimentation. As an organic filter cake develops over the fabric, phosphorus is also removed via the chemical process or sorption.

Subsurface Infiltration System Pretreatment:

Isolator Rows are proposed to provide pretreatment of the stormwater runoff from roadway areas prior to discharging to the adjacent chambers within the subsurface infiltration systems. The use of Isolator Rows is preferred over other proprietary structures because they provide a higher level of pollutant removal based on research at the University of New Hampshire Stormwater Center.

Non-Infiltrative Water Quality Treatment

Overflow from the 1.7-inch water quality volume storm within Bioretention Basins #1, #2B, #5B and #9 will be directed to a subsurface isolator row system wrapped in an impermeable liner with an underdrain. These systems are sized to treat the remainder of the water quality flow rate that could not be managed in these upstream bioretention basins due to space constraints. Stormwater will be treated by the isolator rows and then collected by the underdrains below the chambers, which will discharge to the new closed drainage system within the parking lots.

4.3 Peak Flow Rates

The proposed stormwater management system is expected to reduce the proposed peak runoff rates to at or below the existing rates for the follow design points:

- DP-1: Rodney French Boulevard South 14-inch Outfall
- DP-2: Portland Street 15-inch Outfall

Table 6 below summarize the existing and proposed hydrologic analyses for the site at each design point.

Table 6 – Peak Rates of Runoff in Cubic Feet per Second (cfs)

	Storm Event	1.7-Inch	2-year	10-year	25-year	100-year
DP-1	Existing	2.23	5.86	9.38	11.57	14.90
	Proposed	0.75	4.33	7.62	9.46	14.00
DP-2	Existing	6.88	18.76	30.51	37.90	49.10
	Proposed	3.42	1625	29.37	36.20	47.29

4.4 Stormwater Management During Construction

The Site Contractor will be responsible for stormwater management of the active construction site and is required to provide construction period erosion and sediment controls as provided in the Project plans and specifications.

5.0 STORMWATER MANAGEMENT ANALYSIS

5.1 Methodology

Nitsch Engineering completed a hydrologic analysis of the existing project site utilizing Soil Conservation Service (SCS) Runoff Curve Number (CN) methodology. The SCS method calculates the rate at which the runoff reaches the design point considering several factors: the slope and flow lengths of the subcatchment area, the soil type of the subcatchment area, and the type of surface cover in the subcatchment area. HydroCAD Version 10.00 computer modeling software was used in conjunction with the SCS method to determine the peak runoff rates and runoff volumes for the 2-, 10-, 25-, and 100-year, 24-hour storm events. The proposed project site is being analyzed with the same methodology.

The Site was divided into multiple drainage areas, or subcatchments, which drain to the design points along the property boundary and within the site. For each subcatchment area, SCS Runoff Curve Numbers (CNs) were selected by using the cover type and hydrologic soil group of each area. The peak runoff rates and runoff volumes for the 2-, 10-, 25- and 100-year 24-hour storm events were then determined by inputting the drainage areas, CNs, and time of concentration (T_c) paths into the HydroCAD model.

The National Oceanic and Atmospheric Administration Atlas 14 precipitation frequency estimates were used to calculate the 2-, 10-, 25-, and 100- year 24-hour storm events in HydroCAD. Refer to the HydroCAD calculations in Appendix B and C for rainfall information.

5.2 HydroCAD Version 10.00

The HydroCAD computer program uses SCS and TR-20 methods to model drainage systems. TR-20 (Technical Release 20) was developed by the Soil Conservation Service to estimate runoff and peak discharges in small watersheds. TR-20 is generally accepted by engineers and reviewing authorities as the standard method for estimating runoff and peak discharges.

HydroCAD Version 10.00 uses up to four types of components to analyze the hydrology of a given site: subcatchments, reaches, basins, and links. Subcatchments are areas of land that produce surface runoff. The area, weighted CN, and T_c characterize each individual subcatchment area. Reaches are generally uniform streams, channels, or pipes that convey water from one point to another. A basin is any impoundment that fills with water from one or more sources and empties via an outlet structure. Links are used to introduce hydrographs into a project from another source or to provide a junction for more than one hydrograph within a project. The time span for the model was set for 0-72 hours in order to prevent truncation of the hydrograph.

6.0 WATER QUALITY VOLUME CALCULATIONS

As described, the Project is designed to treat the first 1.7-inches of runoff from the parking lots and the adjacent roadway sections. The Project provides water quality treatment via infiltration of the 1.7-inch water quality volume where separation from groundwater is feasible. Where infiltration is not

feasible, the bioretention basins and the isolator rows are designed to treat the water quality volume via filtration.

The BMPs are designed to treat the 1.7-inch water quality storm to remove on average:

- 80% of the average annual postconstruction load of Total Suspended Solids (TSS) related to the total postconstruction impervious area of the contributing runoff;
- 50% of the average annual load of Total Phosphorus (TP) related to the total post-construction impervious area of the contributing runoff.

Treatment Train A: Bioretention Basins

TSS Removal	TP Removal
90% ^A	60% ^B

Treatment Train B: Lined Bioretention Basin

TSS Removal	TP Removal
90% ^A	60% ^B

Treatment Train C: Bioretention Basin to Isolator Row

TSS Removal	TP Removal
81% ^A	60% ^B

Treatment Train D: Subsurface Infiltration System with Isolator Row

TSS Removal	TP Removal
80% ^A	99% ^B

A) See TSS Removal Worksheet in Appendix A

B) See Phosphorous Removal Charts in Appendix A

See *Appendix B: HydroCAD Calculations – Water Quality Storm (1.7-inches)* for the analysis of the BMPs during the 1.7-inch rainfall event. As shown, each system is designed so that it fully infiltrates or treats the 1.7-inch rainfall event.

Bioretention Basins BB#1, BB#2B, BB#5B, BB#9 cannot feasibly treat the full 1.7-inch water quality volume due to space constraints; therefore, the systems include overflow grates that direct the remainder of the water quality volume to subsurface isolator row systems.

7.0 MassDEP Stormwater Management Standards

The Project is considered a **redevelopment** under the DEP Stormwater Management Standards. As such, the Project is required to meet Standards 2, 3, and the pretreatment and structural best management practice requirements of Standards 4, 5, and 6 only to the maximum extent practicable. Existing stormwater discharges need to comply with Standard 1 only to the maximum extent practicable. The Project will comply with all other Standards. The Site will be designed to meet or meet to the maximum extent practicable the MassDEP Stormwater Management Standards as summarized below:

Standard 1: No New Untreated Discharges

The Project will not discharge any untreated stormwater directly to or cause erosion in wetlands or waters of the Commonwealth. Stormwater from the Site will be collected and treated in accordance with the MassDEP Stormwater Management Standards and stormwater outfalls will be stabilized to prevent erosion.

Standard 2: Peak Rate Attenuation

The proposed stormwater management system will be designed so that the post-development peak discharge rates do not exceed pre-development peak discharge rates. To prevent storm damage and downstream flooding, the proposed stormwater management practices will mitigate peak runoff rates for the 2-, 10-, 25- and 100-year, 24-hour storm events. Refer to Table 6 for a pre- and post-development peak runoff rate comparison.

Standard 3: Groundwater Recharge

The Site was designed using environmentally sensitive site design, low impact development techniques, and green infrastructure stormwater treatment trains to increase annual recharge to groundwater. The annual recharge from the post-development site will approximate the annual recharge from pre-development conditions based on soil type using the guidelines provided in the MassDEP Stormwater Management Handbook.

Impervious Area in HSG A = 2.4 Acres (Parking Lots)
 Rv (Recharge Volume) = 2.4 ac x 43,560 sf/ac x 0.6 in. / (12 inches/ft)
 = 5,227 cubic feet

The infiltration BMPs are sized to exceed the recharge volume required under the MassDEP Stormwater Management Standards (Table 5). The recharge volume shown in Table 7 represents the static storage below the outlet as provided in HydroCAD.

Table 7 – Proposed Recharge Volumes for Stormwater BMPs

Infiltration BMP	Recharge Volume (cf) ^A
Subsurface Infiltration System #1	1,626
Subsurface Infiltration System #2	2,512
Subsurface Infiltration System #3	897
Bioretention Basin #1	270
Bioretention Basin #3A	281
Bioretention Basin #3B	141
Bioretention Basin #6B	223
TOTAL	5,950

a) The recharge volume is based on the static method analysis, which does not consider volume recharged via infiltration. The volume reflected is the storage volume below the outlet.

The HydroCAD reports provided in Appendix C indicate that all proposed infiltration BMPs will drain within 48 hours for the 2-, 10-, 25-, and 100-year storm events, meeting the 72-hour MassDEP drawdown requirement.

Standard 4: Water Quality Treatment

As detailed in Section 3.3., the proposed green infrastructure stormwater improvements have been designed to remove greater than 80% of the average annual post-construction load of Total Suspended Solids (TSS). Structural stormwater BMPs including deep sump and hooded catch basins, Isolator Rows, bioretention areas, and subsurface infiltration systems are sized to capture the required water quality volume (1 inch over the project site) and remove a minimum of 80% of total suspended solids.

Pretreatment for the infiltration basins meet or exceed the 44% TSS removal requirement. Pretreatment for the proposed infiltration basin will be provided using a treatment train that includes a sediment forebay. The sediment forebays were designed in accordance with the MassDEP Stormwater Management Handbook to provide a water quality volume (WQV) equivalent to 0.1-inches per impervious acre (see Section 5.0, Standard 4: Water Quality Treatment). Refer to Figure DR-2A for forebay tributary areas locations.

Basin	Forebay ID	Tributary Impervious Area (SF)	Required Water Quality Volume (CF) *	Volume Provided (CF)
BB-1	BB-1.1	4,485	37	38
	BB-1.2	2,527	21	21
	BB-1.3	2,140	18	35
	BB-1.4	553	5	21
BB-3A	BB-3A.1	1,549	13	38
	BB-3A.2	1,443	12	21
	BB-3A.3	1,160	10	21
BB-3B	BB-3B.1	2,052	17	21
	BB-3B.2	980	8	21
BB-6B	BB-6B.1	1,855	15	21
	BB-6B.2	1,949	16	21
	BB-6B.3	803	7	21

* Required Water Quality Volume is equal to 0.1 inches of rainfall over the impervious area.

The proposed water quality treatment BMPs are subject to the 44% TSS removal pretreatment requirement and the 1-inch rule for calculating water quality volumes to the maximum extent practicable because the site discharges to a bathing beach. Pretreatment prior to infiltration will meet

the 44% TSS removal requirement to the maximum extent practicable using deep sump and hooded catch basins, Isolator Rows, sediment forebays, and the filtration course of the bioretention basins.

TSS removal calculation spreadsheets are provided in Appendix A.

Source control and pollution prevention measures, such as vacuum cleaning, street sweeping, proper snow management, and stabilization of eroded surfaces, are included in the Long-Term Pollution Prevention Plan and Operation and Maintenance Plan (Appendix E).

Standard 5: Land Uses with Higher Potential Pollutant Loads (LUHPPL)

The Project is not considered a LUHPPL and therefore, this standard is not applicable.

Standard 6: Critical Areas

The Project is subject to Standard #6 as it discharges to a bathing beach. The proposed water quality treatment BMPs are subject to the 44% TSS removal pretreatment requirement and the 1-inch water quality volume.

The Project meets these standards to the maximum extent practicable.

Standard 7: Redevelopments

Due to the overall reduction in impervious area, the Project is considered a redevelopment under the MassDEP Stormwater Management Standards. Therefore, the Project is required to meet Standard 2, Standard 3, and the pretreatment and structural stormwater BMP requirements of Standards 4, 5, and 6 to the maximum extent practicable. The Project should comply with all other requirements of the Stormwater Management Standards and improve existing conditions.

The Project meets this standard.

Standard 8: Construction Period Pollution Prevention and Sedimentation Control

A plan to control construction-related impacts, including erosion, sedimentation, and other pollutant sources during construction and land disturbance activities (construction period erosion, sedimentation, and pollution prevention plan) will be developed and implemented during the Notice of Intent permitting process. The contractor will be required to implement construction-period erosion and sediment controls as documented in the Project plan and specifications. These requirements include erosion and sediment controls (stabilization practices and structural practices), temporary and permanent stormwater management measures, materials management, waste disposal, off-site vehicle tracking, and spill prevention and response.

Standard 9: Operation and Maintenance Plan

A post-construction operation and maintenance plan has been prepared and will be implemented to ensure that stormwater management systems function as designed. Source control and stormwater BMP operation requirements for the site are summarized in the Long-Term Pollution Prevention Plan and Operation and Maintenance Plan provided in Appendix E.

Standard 10: Prohibition of Illicit Discharges

There will be no illicit discharges to the stormwater management system associated with the Project. An Illicit Discharge Compliance Statement is provided in Appendix A.

8.0 CONCLUSION

In conclusion, the Project is providing significant improvements to stormwater being discharged to East Beach through the implementation of green infrastructure and water quality treatment BMPs including bioretention basins, increased vegetation, and infiltration. The proposed stormwater improvements will reduce peak runoff rates and volumes and improve the water quality of stormwater being discharged from the Site. The Project has been designed to meet and exceed the MassDEP Stormwater Management Standards and the City of New Bedford Stormwater Management Rules and Regulations. The Project was also designed to align with the City of New Bedford Green Infrastructure Plan stormwater quality volume goals.

FIGURES

DR-1A	Existing Watershed Areas (30 Scale)
DR-1B	Existing Watershed Areas (100 Scale)
DR-2A	Proposed Watershed Areas (30 Scale)
DR-2B	Proposed Watershed Areas (100 Scale)

4/16/2022 9:18 AM
 G:\10000-14850-eastbeachpark\p\main\14850-eastbeachpark\p\main\14850-eastbeachpark\14850-cda-1.7.dwg

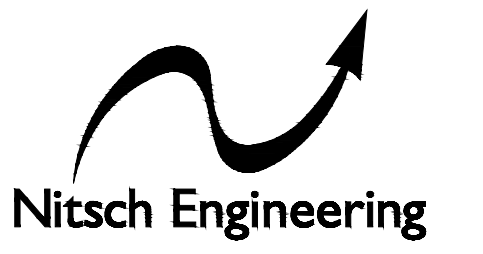
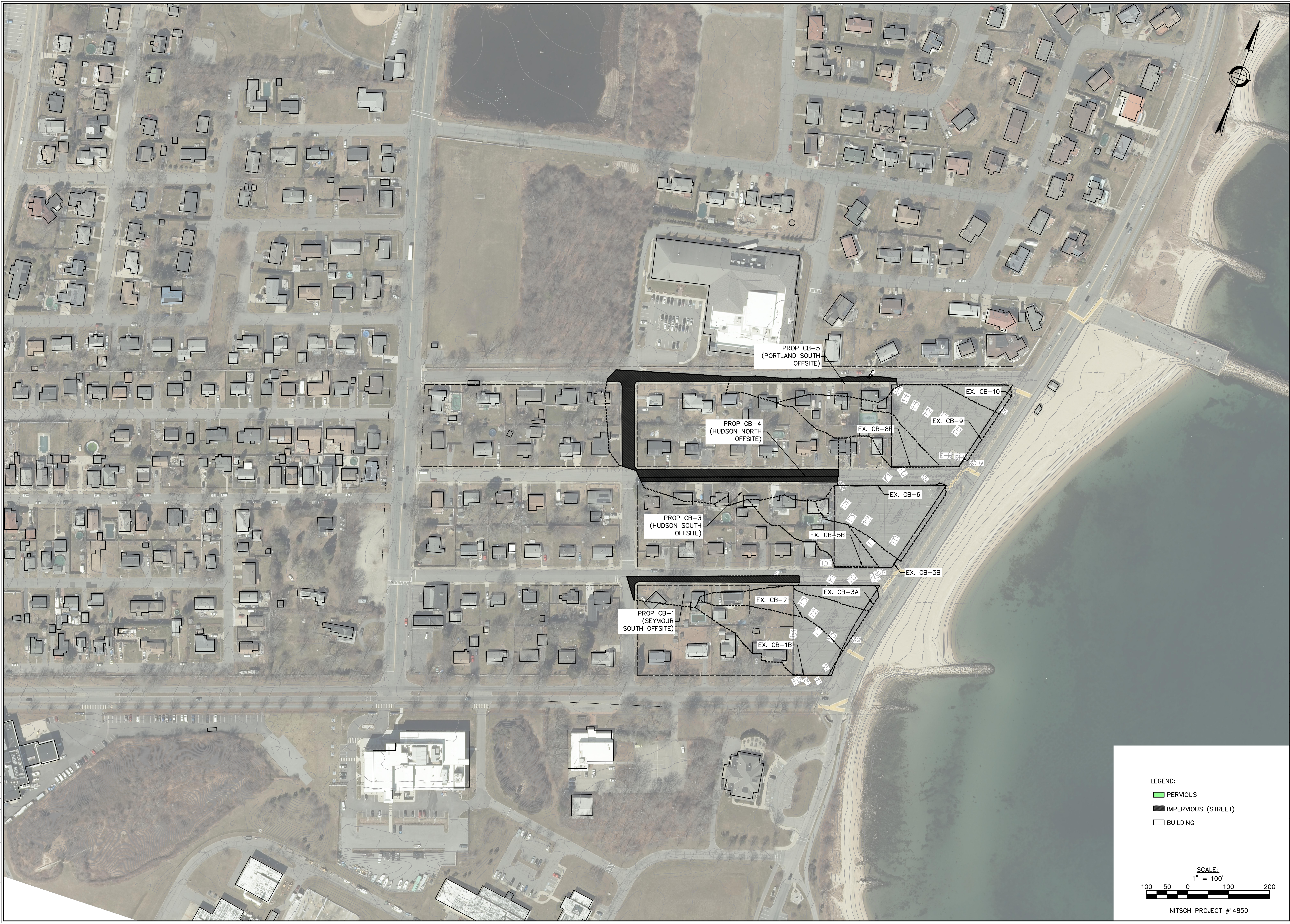

Nitsch Engineering
www.nitscheng.com
 2 Center Plaza, Suite 430
 Boston, MA 02108
 T: (617) 338-0063
 F: (617) 338-6472

- ▶ Civil Engineering
- ▶ Land Surveying
- ▶ Transportation Engineering
- ▶ Structural Engineering
- ▶ Green Infrastructure
- ▶ Planning
- ▶ GIS

EXISTING DRAINAGE AREAS
 EAST BEACH PARKING LOT GREEN INFRASTRUCTURE RETROFIT
 WS EAST RODNEY FRENCH BOULEVARD, NEW BEDFORD, MA 02744

PREPARED FOR:
CITY OF NEW BEDFORD
 181 HILLMAN STREET #3, NEW BEDFORD, MA 02740

REV.	COMMENTS	DATE

NITSCH PROJECT # 14850
 FILE: 14850-CDA-1.7.DWG
 SCALE: 1"=100'
 DATE: 04/06/2022
 PROJECT MANAGER: BC
 SURVEYOR:
 DRAFTED BY: KLK
 CHECKED BY: JW

SHEET:
DR-1A
 OF REV.

- LEGEND:
- PERVIOUS
 - IMPERVIOUS (STREET)
 - BUILDING

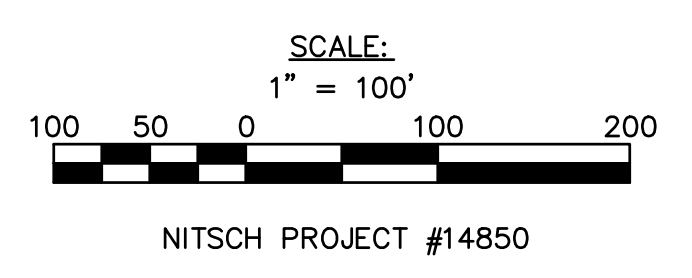

4/22/2022 9:22 PM

D:\10000-14850-eastbeachpark\p\main\14850-eastbeachpark\p\main\14850-cda-1.7.dwg

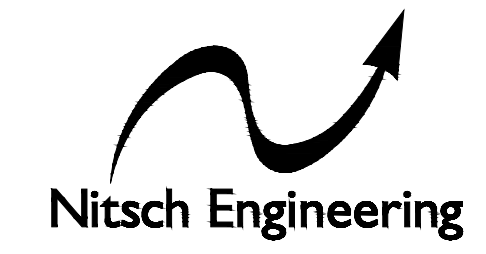

Nitsch Engineering
 www.nitscheng.com
 2 Center Plaza, Suite 430
 Boston, MA 02108
 T: (617) 338-0063
 F: (617) 338-6472

- ▶ Civil Engineering
- ▶ Land Surveying
- ▶ Transportation Engineering
- ▶ Structural Engineering
- ▶ Green Infrastructure
- ▶ Planning
- ▶ GIS

PROPOSED DRAINAGE AREAS
 EAST BEACH PARKING LOT GREEN INFRASTRUCTURE RETROFIT
 WS EAST RODNEY FRENCH BOULEVARD, NEW BEDFORD, MA 02744

PREPARED FOR:
CITY OF NEW BEDFORD
 181 HILLMAN STREET #3, NEW BEDFORD, MA 02740

REV.	COMMENTS	DATE

NITSCH PROJECT # 14850
 FILE: 14850-CDA-1.7.DWG
 SCALE: 1"=100'
 DATE: 04/06/2022
 PROJECT MANAGER: BC
 SURVEYOR:
 DRAFTED BY: KLK
 CHECKED BY: JW

SHEET:
DR-2A
 OF REV.

LEGEND:
■ PERVIOUS
 IMPERVIOUS (STREET)
 BUILDING

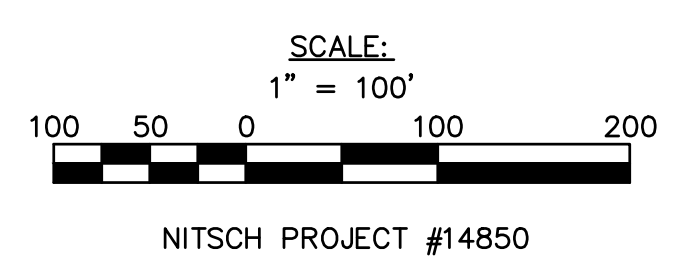

APPENDIX A

Stormwater Management Standards Documentation

MassDEP Checklist for Stormwater Report

Standard 4: TSS Removal Calculations

Phosphorous Removal Calculations

Standard 4: Isolator Row Sizing Calculations

Standard 10: Illicit Discharge Compliance Statement





Checklist for Stormwater Report

B. Stormwater Checklist and Certification

The following checklist is intended to serve as a guide for applicants as to the elements that ordinarily need to be addressed in a complete Stormwater Report. The checklist is also intended to provide conservation commissions and other reviewing authorities with a summary of the components necessary for a comprehensive Stormwater Report that addresses the ten Stormwater Standards.

Note: Because stormwater requirements vary from project to project, it is possible that a complete Stormwater Report may not include information on some of the subjects specified in the Checklist. If it is determined that a specific item does not apply to the project under review, please note that the item is not applicable (N.A.) and provide the reasons for that determination.

A complete checklist must include the Certification set forth below signed by the Registered Professional Engineer who prepared the Stormwater Report.

Registered Professional Engineer's Certification

I have reviewed the Stormwater Report, including the soil evaluation, computations, Long-term Pollution Prevention Plan, the Construction Period Erosion and Sedimentation Control Plan (if included), the Long-term Post-Construction Operation and Maintenance Plan, the Illicit Discharge Compliance Statement (if included) and the plans showing the stormwater management system, and have determined that they have been prepared in accordance with the requirements of the Stormwater Management Standards as further elaborated by the Massachusetts Stormwater Handbook. I have also determined that the information presented in the Stormwater Checklist is accurate and that the information presented in the Stormwater Report accurately reflects conditions at the site as of the date of this permit application.

Registered Professional Engineer Block and Signature

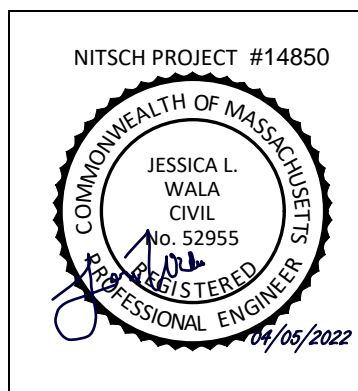

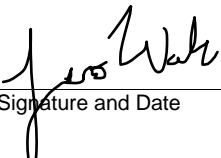
 4/5/22
Signature and Date

Checklist

Project Type: Is the application for new development, redevelopment, or a mix of new and redevelopment?

- New development
- Redevelopment
- Mix of New Development and Redevelopment



Checklist for Stormwater Report

Checklist (continued)

LID Measures: Stormwater Standards require LID measures to be considered. Document what environmentally sensitive design and LID Techniques were considered during the planning and design of the project:

- No disturbance to any Wetland Resource Areas
 - Site Design Practices (e.g. clustered development, reduced frontage setbacks)
 - Reduced Impervious Area (Redevelopment Only)
 - Minimizing disturbance to existing trees and shrubs
 - LID Site Design Credit Requested:
 - Credit 1
 - Credit 2
 - Credit 3
 - Use of “country drainage” versus curb and gutter conveyance and pipe
 - Bioretention Cells (includes Rain Gardens)
 - Constructed Stormwater Wetlands (includes Gravel Wetlands designs)
 - Treebox Filter
 - Water Quality Swale
 - Grass Channel
 - Green Roof
 - Other (describe): Subsurface Infiltration System
-

Standard 1: No New Untreated Discharges

- No new untreated discharges
- Outlets have been designed so there is no erosion or scour to wetlands and waters of the Commonwealth
- Supporting calculations specified in Volume 3 of the Massachusetts Stormwater Handbook included.



Checklist for Stormwater Report

Checklist (continued)

Standard 2: Peak Rate Attenuation

- Standard 2 waiver requested because the project is located in land subject to coastal storm flowage and stormwater discharge is to a wetland subject to coastal flooding.
- Evaluation provided to determine whether off-site flooding increases during the 100-year 24-hour storm.
- Calculations provided to show that post-development peak discharge rates do not exceed pre-development rates for the 2-year and 10-year 24-hour storms. If evaluation shows that off-site flooding increases during the 100-year 24-hour storm, calculations are also provided to show that post-development peak discharge rates do not exceed pre-development rates for the 100-year 24-hour storm.

Standard 3: Recharge

- Soil Analysis provided.
- Required Recharge Volume calculation provided.
- Required Recharge volume reduced through use of the LID site Design Credits.
- Sizing the infiltration, BMPs is based on the following method: Check the method used.
 - Static
 - Simple Dynamic
 - Dynamic Field¹
- Runoff from all impervious areas at the site discharging to the infiltration BMP.
- Runoff from all impervious areas at the site is *not* discharging to the infiltration BMP and calculations are provided showing that the drainage area contributing runoff to the infiltration BMPs is sufficient to generate the required recharge volume.
- Recharge BMPs have been sized to infiltrate the Required Recharge Volume.
- Recharge BMPs have been sized to infiltrate the Required Recharge Volume *only* to the maximum extent practicable for the following reason:
 - Site is comprised solely of C and D soils and/or bedrock at the land surface
 - M.G.L. c. 21E sites pursuant to 310 CMR 40.0000
 - Solid Waste Landfill pursuant to 310 CMR 19.000
 - Project is otherwise subject to Stormwater Management Standards only to the maximum extent practicable.
- Calculations showing that the infiltration BMPs will drain in 72 hours are provided.
- Property includes a M.G.L. c. 21E site or a solid waste landfill and a mounding analysis is included.

¹ 80% TSS removal is required prior to discharge to infiltration BMP if Dynamic Field method is used.



Checklist for Stormwater Report

Checklist (continued)

Standard 3: Recharge (continued)

- The infiltration BMP is used to attenuate peak flows during storms greater than or equal to the 10-year 24-hour storm and separation to seasonal high groundwater is less than 4 feet and a mounding analysis is provided.
- Documentation is provided showing that infiltration BMPs do not adversely impact nearby wetland resource areas.

Standard 4: Water Quality

The Long-Term Pollution Prevention Plan typically includes the following:

- Good housekeeping practices;
 - Provisions for storing materials and waste products inside or under cover;
 - Vehicle washing controls;
 - Requirements for routine inspections and maintenance of stormwater BMPs;
 - Spill prevention and response plans;
 - Provisions for maintenance of lawns, gardens, and other landscaped areas;
 - Requirements for storage and use of fertilizers, herbicides, and pesticides;
 - Pet waste management provisions;
 - Provisions for operation and management of septic systems;
 - Provisions for solid waste management;
 - Snow disposal and plowing plans relative to Wetland Resource Areas;
 - Winter Road Salt and/or Sand Use and Storage restrictions;
 - Street sweeping schedules;
 - Provisions for prevention of illicit discharges to the stormwater management system;
 - Documentation that Stormwater BMPs are designed to provide for shutdown and containment in the event of a spill or discharges to or near critical areas or from LUHPPL;
 - Training for staff or personnel involved with implementing Long-Term Pollution Prevention Plan;
 - List of Emergency contacts for implementing Long-Term Pollution Prevention Plan.
- A Long-Term Pollution Prevention Plan is attached to Stormwater Report and is included as an attachment to the Wetlands Notice of Intent.
 - Treatment BMPs subject to the 44% TSS removal pretreatment requirement and the one inch rule for calculating the water quality volume are included, and discharge:
 - is within the Zone II or Interim Wellhead Protection Area
 - is near or to other critical areas
 - is within soils with a rapid infiltration rate (greater than 2.4 inches per hour)
 - involves runoff from land uses with higher potential pollutant loads.
 - The Required Water Quality Volume is reduced through use of the LID site Design Credits.
 - Calculations documenting that the treatment train meets the 80% TSS removal requirement and, if applicable, the 44% TSS removal pretreatment requirement, are provided.



Checklist for Stormwater Report

Checklist (continued)

Standard 4: Water Quality (continued)

- The BMP is sized (and calculations provided) based on:
 - The ½" or 1" Water Quality Volume or
 - The equivalent flow rate associated with the Water Quality Volume and documentation is provided showing that the BMP treats the required water quality volume.
- The applicant proposes to use proprietary BMPs, and documentation supporting use of proprietary BMP and proposed TSS removal rate is provided. This documentation may be in the form of the propriety BMP checklist found in Volume 2, Chapter 4 of the Massachusetts Stormwater Handbook and submitting copies of the TARP Report, STEP Report, and/or other third party studies verifying performance of the proprietary BMPs.
- A TMDL exists that indicates a need to reduce pollutants other than TSS and documentation showing that the BMPs selected are consistent with the TMDL is provided.

Standard 5: Land Uses With Higher Potential Pollutant Loads (LUHPPLs)

- The NPDES Multi-Sector General Permit covers the land use and the Stormwater Pollution Prevention Plan (SWPPP) has been included with the Stormwater Report.
- The NPDES Multi-Sector General Permit covers the land use and the SWPPP will be submitted **prior to** the discharge of stormwater to the post-construction stormwater BMPs.
- The NPDES Multi-Sector General Permit does **not** cover the land use.
- LUHPPLs are located at the site and industry specific source control and pollution prevention measures have been proposed to reduce or eliminate the exposure of LUHPPLs to rain, snow, snow melt and runoff, and been included in the long term Pollution Prevention Plan.
- All exposure has been eliminated.
- All exposure has **not** been eliminated and all BMPs selected are on MassDEP LUHPPL list.
- The LUHPPL has the potential to generate runoff with moderate to higher concentrations of oil and grease (e.g. all parking lots with >1000 vehicle trips per day) and the treatment train includes an oil grit separator, a filtering bioretention area, a sand filter or equivalent.

Standard 6: Critical Areas

- The discharge is near or to a critical area and the treatment train includes only BMPs that MassDEP has approved for stormwater discharges to or near that particular class of critical area.
- Critical areas and BMPs are identified in the Stormwater Report.



Checklist for Stormwater Report

Checklist (continued)

Standard 7: Redevelopments and Other Projects Subject to the Standards only to the maximum extent practicable

- The project is subject to the Stormwater Management Standards only to the maximum Extent Practicable as a:
- Limited Project
 - Small Residential Projects: 5-9 single family houses or 5-9 units in a multi-family development provided there is no discharge that may potentially affect a critical area.
 - Small Residential Projects: 2-4 single family houses or 2-4 units in a multi-family development with a discharge to a critical area
 - Marina and/or boatyard provided the hull painting, service and maintenance areas are protected from exposure to rain, snow, snow melt and runoff
 - Bike Path and/or Foot Path
 - Redevelopment Project
 - Redevelopment portion of mix of new and redevelopment.
- Certain standards are not fully met (Standard No. 1, 8, 9, and 10 must always be fully met) and an explanation of why these standards are not met is contained in the Stormwater Report.
- The project involves redevelopment and a description of all measures that have been taken to improve existing conditions is provided in the Stormwater Report. The redevelopment checklist found in Volume 2 Chapter 3 of the Massachusetts Stormwater Handbook may be used to document that the proposed stormwater management system (a) complies with Standards 2, 3 and the pretreatment and structural BMP requirements of Standards 4-6 to the maximum extent practicable and (b) improves existing conditions.

Standard 8: Construction Period Pollution Prevention and Erosion and Sedimentation Control

A Construction Period Pollution Prevention and Erosion and Sedimentation Control Plan must include the following information:

- Narrative;
 - Construction Period Operation and Maintenance Plan;
 - Names of Persons or Entity Responsible for Plan Compliance;
 - Construction Period Pollution Prevention Measures;
 - Erosion and Sedimentation Control Plan Drawings;
 - Detail drawings and specifications for erosion control BMPs, including sizing calculations;
 - Vegetation Planning;
 - Site Development Plan;
 - Construction Sequencing Plan;
 - Sequencing of Erosion and Sedimentation Controls;
 - Operation and Maintenance of Erosion and Sedimentation Controls;
 - Inspection Schedule;
 - Maintenance Schedule;
 - Inspection and Maintenance Log Form.
- A Construction Period Pollution Prevention and Erosion and Sedimentation Control Plan containing the information set forth above has been included in the Stormwater Report.



Checklist for Stormwater Report

Checklist (continued)

Standard 8: Construction Period Pollution Prevention and Erosion and Sedimentation Control (continued)

- The project is highly complex and information is included in the Stormwater Report that explains why it is not possible to submit the Construction Period Pollution Prevention and Erosion and Sedimentation Control Plan with the application. A Construction Period Pollution Prevention and Erosion and Sedimentation Control has **not** been included in the Stormwater Report but will be submitted **before** land disturbance begins.
- The project is **not** covered by a NPDES Construction General Permit.
- The project is covered by a NPDES Construction General Permit and a copy of the SWPPP is in the Stormwater Report.
- The project is covered by a NPDES Construction General Permit but no SWPPP been submitted. The SWPPP will be submitted BEFORE land disturbance begins.

Standard 9: Operation and Maintenance Plan

- The Post Construction Operation and Maintenance Plan is included in the Stormwater Report and includes the following information:
 - Name of the stormwater management system owners;
 - Party responsible for operation and maintenance;
 - Schedule for implementation of routine and non-routine maintenance tasks;
 - Plan showing the location of all stormwater BMPs maintenance access areas;
 - Description and delineation of public safety features;
 - Estimated operation and maintenance budget; and
 - Operation and Maintenance Log Form.
- The responsible party is **not** the owner of the parcel where the BMP is located and the Stormwater Report includes the following submissions:
 - A copy of the legal instrument (deed, homeowner's association, utility trust or other legal entity) that establishes the terms of and legal responsibility for the operation and maintenance of the project site stormwater BMPs;
 - A plan and easement deed that allows site access for the legal entity to operate and maintain BMP functions.

Standard 10: Prohibition of Illicit Discharges

- The Long-Term Pollution Prevention Plan includes measures to prevent illicit discharges;
- An Illicit Discharge Compliance Statement is attached;
- NO Illicit Discharge Compliance Statement is attached but will be submitted **prior to** the discharge of any stormwater to post-construction BMPs.

**EAST BEACH, NEW BEDFORD, MA
TSS REMOVAL – WATER QUALITY TREATMENT SUMMARY**

Nitsch Engineering has prepared this Water Quality Treatment Summary for the proposed East Beach in New Bedford, MA. In compliance with MassDEP Stormwater Management Standard #4, the proposed stormwater management system is designed to remove at least 80% of the average annual post-construction load of TSS prior to discharge. The stormwater management system is designed to remove at least 44% of the average annual post-construction TSS load prior to discharge to the infiltration systems to the maximum extent practicable.

A summary of treatment trains proposed to provide water quantity control and water quality improvement at the proposed project site is provided below.

Treatment Train A
Infiltration Bioretention Basin
[BB#3A, BB#3B, BB#6B]

Parking Lot Runoff + Contributing Residential Parcels → Sediment Forebay → Bioretention Basin

Treatment Train B
Lined Biofiltration Basin
[BB#2A, BB#4A, BB#4B, BB#5A, BB#6A, BB#7A, BB#7B, BB#8A, BB#8B]
Parking Lot Runoff + Contributing Residential Parcels → Biofiltration Basin

Treatment Train C
Bioretention Basin, overflow to Isolator Rows
[BB#1, BB#2B, BB#5B, BB#9]
Parking Lot Runoff + Contributing Residential Parcels → Overflow to Isolator Row

Treatment Train D
Upstream Watershed to Infiltration System
[CB1, CB3, CB4, CB5]
Roadway and Residential Runoff → Isolator Row → Infiltration System



Treatment Train A

Parking Lot Runoff + Contributing Residential Parcels → Sediment Forebay → Bioretention Basin

Pretreatment Spreadsheet

B	C	D	E	F
BMP	TSS Removal Rate	Starting TSS Load	Amount Removed (C*D)	Remaining Load (D-E)
Sediment Forebay	0.25	1.00	0.25	0.75

Total TSS Removal =

25%

**Project is a
 Redevelopment –
 Meets standard to
 maximum extent
 practicable**

Treatment Spreadsheet

B	C	D	E	F
BMP	TSS Removal Rate	Starting TSS Load	Amount Removed (C*D)	Remaining Load (D-E)
Bioretention Basin	0.90	1.00	0.90	0.10

Total TSS Removal =

90%

**Meets 80% TSS
 removal requirement**

Treatment Train B

Parking Lot Runoff + Contributing Residential Parcels → Lined Biofiltration Basin

Treatment Spreadsheet

B BMP	C TSS Removal Rate	D Starting TSS Load	E Amount Removed (C*D)	F Remaining Load (D-E)
Bioretention Basin	0.90	1.00	0.90	0.10

Total TSS Removal =

90%

**Meets 80% TSS
removal requirement**



Treatment Train C

Parking Lot Runoff + Contributing Residential Parcels → Overflow to Isolator Row

Treatment Spreadsheet

B BMP	C TSS Removal Rate	D Starting TSS Load	E Amount Removed (C*D)	F Remaining Load (D-E)
Isolator Row	0.81	1.00	0.82	0.19

Total TSS Removal =

81%

**Meets 80% TSS
removal requirement**



Treatment Train D

Parking Lot Runoff + Contributing Residential Parcels → Sediment Forebay → Bioretention Basin

Pretreatment Spreadsheet

B BMP	C TSS Removal Rate	D Starting TSS Load	E Amount Removed (C*D)	F Remaining Load (D-E)
Deep Sump & Hooded Manhole	0.25	1.00	0.25	0.75
Isolator Row	0.81	0.75	0.61	0.14

Total TSS Removal =

86%

Meets 44% TSS removal pretreatment requirement

Treatment Spreadsheet

B BMP	C TSS Removal Rate	D Starting TSS Load	E Amount Removed (C*D)	F Remaining Load (D-E)
Infiltration System	0.80	1.00	0.80	0.20

Total TSS Removal =

80%

Meets 80% TSS removal requirement



University of New Hampshire
Stormwater Center



2009 BIENNIAL REPORT

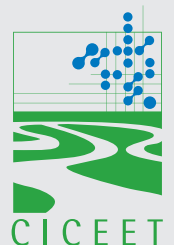

Contents

- 3 Directors' Message
- 4 Highlights
- 8 Field Research Site
- 10 Applying UNHSC Research
- 12 Reading this Report
- 14–30 Stormwater Treatment System Data
 - 14 Porous Asphalt
 - 16 Pervious Concrete
 - 18 Subsurface Gravel Wetland
 - 20 Bioretention Systems
 - 22 Tree Box Filter
 - 24 StormTech Isolator Row
 - 26 Retention Ponds
 - 28 Deep Sump Catch Basins
 - 30 Filter Berm Swales
- 32–34 Targeted Research
- 35 Administration

Workshop at UNHSC field site



About the Center

The University of New Hampshire Stormwater Center (UNHSC) is dedicated to the protection of water resources through effective stormwater management.

Center researchers evaluate and enhance the ability of stormwater treatment systems to treat the pollution in stormwater runoff and reduce the flooding that it can cause. The Center provides information on performance, cost, design, and maintenance to people who select, review, permit, design, install, and maintain stormwater management systems. The research is integrated with an evolving outreach

program that supports a wide range of stormwater managers and professionals who seek to build programs that protect water quality, preserve environmental values, and reduce the impact of stormwater runoff.

The Center receives its primary funding and program support from the Cooperative Institute for Coastal and Estuarine Environmental Technology (CICEET), a partnership of UNH and the National Oceanic and Atmospheric Administration (NOAA). It is housed within the University's Environmental Research Group, a division of the College of Engineering and Physical Sciences.

Resources for Stormwater Managers

The Center's research has served as the foundation for a range of outreach products—from best management practice (BMP) workshops geared to support municipal decision makers and stormwater engineers to peer-reviewed publications that explore the frontiers of stormwater science. Learn more about these resources at www.unh.edu/erg/cstev.



- BMP Fact Sheets
- Data Reports
- Design Drawings
- Design Specs
- Journal Articles
- Web Resources

Directors' Message



UNH Stormwater Center
field site

These economic times challenge all of us to make difficult choices about what we can and cannot afford. For state and local governments facing budget shortfalls, the University of New Hampshire Stormwater Center has some welcome news: when it comes to effective stormwater management, you do not have to choose between affordability and healthy waters.

People often tell us that they think they do have to choose, that even if Low Impact Development (LID) stormwater techniques do a better job of protecting water quality, they are too costly to install and maintain. Yet our research is demonstrating that this is not the case. Since 2004 we have monitored the ability of 23 stormwater systems to treat pollution and reduce the volume of runoff. We have worked with hundreds of municipal officials, regulators, engineers, contractors, and educators on dozens of stormwater demonstration and education projects.

In the process, we have found that projects that use LID approaches to managing stormwater runoff can be both more effective in treating pollution and in some instances less expensive to install than those that rely on curbs, pipes, and ponds. LID systems do require maintenance to function properly, but so do all of the commonly used systems that are believed to require little or no attention. In particular, our research has demonstrated that when retention ponds are not adequately maintained, they not only fail to remove pollutants from runoff; they can magnify the negative impact of polluted stormwater on receiving waters.

Using LID approaches for stormwater management involves decentralizing runoff and maximizing infiltration, which ultimately reduces the stress on urban stormwater infrastructure. Metropolitan areas like Portland, OR., are already seeing the economic benefits of using LID to reduce the runoff flowing through their combined sewers. These savings extend to residential and commercial development and redevelopment projects. Homeowners that use techniques like rain barrels, drought resistant rain gardens, and porous pavements can save on water utility bills and help prevent flooded basements.

By allowing for these less familiar but more effective techniques in stormwater ordinances, municipalities can help insure these benefits at every level. In so doing, they anticipate the inevitable. Federal laws requiring LID-style approaches to stormwater are already in place as part of Phase II of the Clean Water Act. It is only a matter of time before all municipalities will have to comply with mandates to clean up impaired waters, and our research is showing that in many cases an LID approach to stormwater management is essential in meeting that goal.

A proactive response to federal regulations has the added benefit of preparing us for the impacts of climate change. Whether climate change has brought severe storms or drought to a community, LID stormwater techniques can help mitigate the flooding associated with impervious surfaces, can allow rainfall to replenish aquifers, and can be powerful tools for adaptive management.

This report is one of many tools we use to communicate our work in a way that we hope stormwater managers from many backgrounds will find useful. We welcome your comments and questions, about this report and all of the work we do.

Sincerely,

Handwritten signature of Robert Roseen in black ink.

Robert Roseen
Director

Handwritten signature of Thomas Ballestero in black ink.

Thomas Ballestero
Senior Scientist

Handwritten signature of Jamie Houle in black ink.

Jamie Houle
Program Manager
and Outreach Coordinator

StormTech Isolator Row



The StormTech Isolator Row is an effective filtration/infiltration system best suited to locations where space is at a premium and the system's relatively expensive installation cost can be offset by increasing available space for development.

About the StormTech Isolator Row

The StormTech Isolator Row is a manufactured system designed to provide subsurface water quality treatment and easy access for maintenance. It is typically used to remove pollution from runoff before it flows into unlined infiltration chambers designed for detention and water quantity control. The Isolator Row consists of a series of StormTech chambers installed over a layer of woven geotextile, which sits on a crushed stone infiltration bed surrounded with filter fabric. The bed is directly connected to an upstream manhole for maintenance access and large storm bypass. At UNHSC, the Isolator Row has met a TSS median annual removal standard of 80 percent, and exhibited an enhanced capacity to remove phosphorus. The Isolator Row is well suited for urban environments where space is at a premium.

Implementation

The StormTech Isolator Row is part of a class of manufactured, subsurface filtration/infiltration systems that are being used more and more throughout the United States. In general, these systems are best suited to locations where above ground space is at a premium. They are often used in urban areas, where they are located beneath parking lots and other

infrastructure. As with any infiltration system, care must be taken when locating these systems near pollution hotspots, or where seasonal high groundwater levels may lead to groundwater contamination. In such cases, if installed, the systems should be lined to prevent infiltration into groundwater, and outfitted with subdrains that discharge to the surface. Designs for the StormTech Isolator Row are available from the manufacturer.

System Performance

Cost & Maintenance

While subsurface HDPE systems such as the Isolator Row tend to be more expensive than conventional stormwater treatments like retention ponds, the costs are ameliorated by the increase in available space for development. The cost to install a StormTech Isolator Row system large enough to treat runoff from one acre of impervious surface was \$34,000 in 2006.

In more than two years of operation, the system is at less than 50 percent of its recommended maintenance trigger point. Maintenance should be conducted when the sediment in the chambers reaches approximately three inches in depth according to recommendations from the manufacturer. Sediment accumulation can be monitored through inspection ports. When maintenance is needed, the entire row can be

CATEGORY / BMP TYPE	Water Quality: Physical (Sedimentation, Filtration) & Chemical (Sorption)	SPECIFICATIONS	MAINTENANCE
Filtration, Infiltration, Manufactured Treatment Device		Catchment Area: 1 acre	Maintenance Sensitivity: Low
UNIT OPERATIONS & PROCESSES	DESIGN SOURCE: StormTech, LLC	Water Quality Flow: 1 cfs	Inspections: High
Hydrologic (Flow Alteration)	BASIC DIMENSIONS: Chamber: 51" wide X 30" high X 85.4" long	Water Quality Volume: 3,300 cf	Sediment Removal: Moderate
		INSTALLATION COST: \$34,000 per acre treated	

Fast Facts

How the System Works

WATER QUALITY TREATMENT PROCESS

1. Runoff flows into the Isolator Row chambers from a catchbasin or pipe.
2. Runoff slowly passes from the chambers through a woven geotextile fabric and into the crushed stone reservoir below the system. The runoff passes through the fabric, leaving behind sediments and associated contaminants through the physical unit operations of filtration and sedimentation. As an organic filter cake develops over the fabric, phosphorus is also removed via the chemical process of sorption.
3. Filtered runoff collects in a perforated subdrain and returns to a storm drain system, infiltrates into the subgrade, or is discharged to the surface.

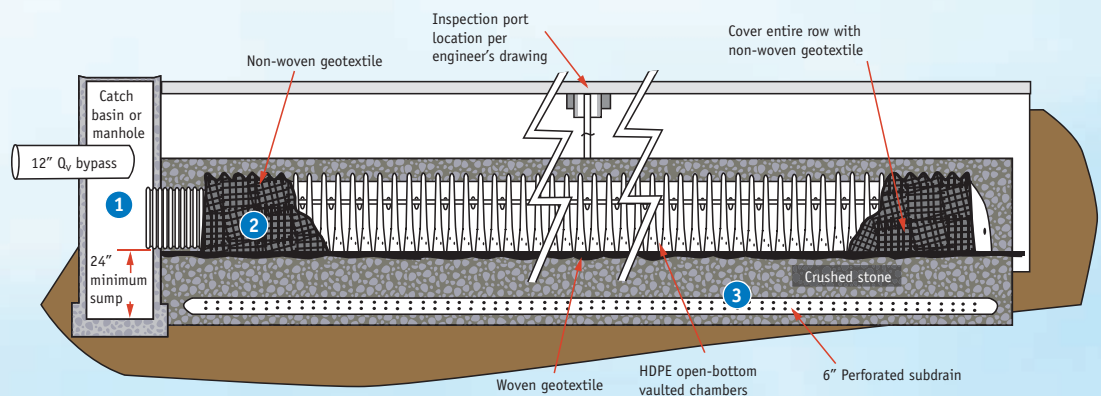

washed clean through an access manhole and by a hydro-jet with sediment removed by vactoring (vacuuming). Entry into the system is considered a confined space entry and requires trained personnel and equipment.

During two years of evaluation at UNHSC, the Isolator Row has accumulated, at most, one and one half inches of sediment in its chambers. As a result, researchers have not performed maintenance on the system. The Isolator Row presents an interesting opportunity to study the relationship between maintenance and performance. Researchers have observed enhanced phosphorus removal as the system develops an organic filter cake between the chambers and the woven geotextile fabric that lies beneath them. This enhancement is tempered by the likelihood that, as the filter cake continues to grow, hydraulic efficiency will decline and more runoff will bypass the system untreated until maintenance is performed. Analyses are underway to develop maintenance recommendations that balance and optimize the water quality and water quantity management abilities of this system.

Cold Climate

This system's water quality treatment and volume control capacity remained strong in all seasons, reinforcing the conclusion that filtration and infiltration systems perform well, even in cold climates.

Water Quality Treatment

The StormTech Isolator Row system does a good job of reducing the concentration of common pollutants associated with stormwater performance assessment with the exception of nitrogen. It generally meets EPA's recommended level of removal for total suspended solids, and meets regional ambient water quality criteria for heavy metals and petroleum hydrocarbons. The system has a capacity to achieve modest levels of total phosphorus removal, which may be enhanced over time. (See Cost & Maintenance Section.) The lack of nitrogen treatment is typical for non-vegetated aerobic systems. Nutrient load reduction would be further increased through volume reduction by infiltration. Like all other systems monitored at UNHSC, it does not provide chloride removal.

The chart at top right reflects the system's performance in removing total suspended solids, total petroleum hydrocarbons, dissolved inorganic nitrogen, total phosphorus, and zinc. Values represent results recorded over a two-year monitoring period, with the data further divided into summer and winter components.

Water Quantity Control

Like other infiltration and filtration systems, the StormTech Isolator Row system exhibits the capacity to reduce peak flows and could be used to reduce runoff volume in appropriate soils, such as those belonging to groups "A" or "B." The figure at bottom right provides information on peak flow reduction and lag times for the system.

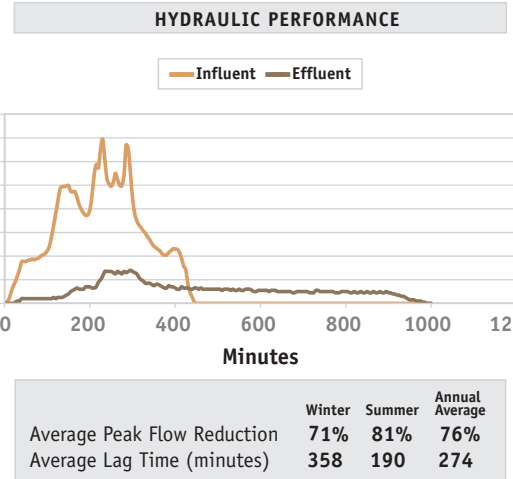
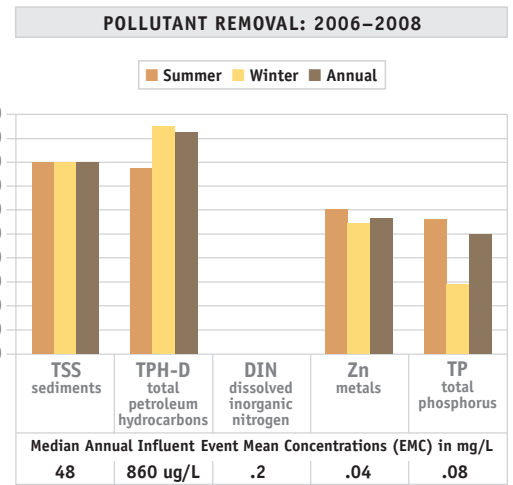

SYSTEM DESIGN ▼

The StormTech Isolator Row is designed to provide subsurface water quality treatment for small storms. The manufacturer adapts the system's design in accordance with local watershed conditions and target treatment objectives.

Chamber units are made of high-density polyethylene (HDPE) pipe and are designed to bear loads consistent with those experienced by parking lots. The UNHSC chamber dimensions are 51 x 30 x 85.4 inches and can be linked together to form linear rows up to 200 feet long. The chambers are laid over woven geotextile, which rests on an infiltration base composed of one foot of three quarter inch crushed stone. The entire excavation is then wrapped in nonwoven geotextile to protect the system from the migration of fine particles from the surrounding soil.

A three- to five-foot separation from seasonal high groundwater table (as designated by regulations) is necessary to minimize the potential for groundwater contamination. Stormwater flows of

up to one cubic foot per second (cfs) enter the system through an upstream manhole or other flow diverter. This is representative of flow-based sizing of a BMP common for devices that have limited detention or storage. Such devices are often better described by a maximum treatable flow rate as opposed to a treatment volume.

A bypass is incorporated in the StormTech system where flows exceeding the design rate are bypassed around the device and flow directly into adjacent chambers that can be sized to treat the C_p and Q_p . Because of the bypass design, maintenance requirements are extremely important. A poorly maintained device would bypass prematurely into the unlined chamber systems and eventually clog subsurface soils resulting in system failure.

Table 3-18: Bio-filtration BMP Performance Table

Bio-filtration BMP Performance Table: Long-Term Phosphorus & Nitrogen Load Reduction								
BMP Capacity: Depth of Runoff from Impervious Area (inches)	0.1	0.2	0.4	0.6	0.8	1.0	1.5	2.0
Cumulative Phosphorus Load Reduction	14%	25%	37%	44%	48%	53%	58%	63%
Cumulative Nitrogen Load Reduction	9%	16%	23%	28%	31%	32%	37%	40%

Figure 3- 13: BMP Performance Curve: Bio-filtration

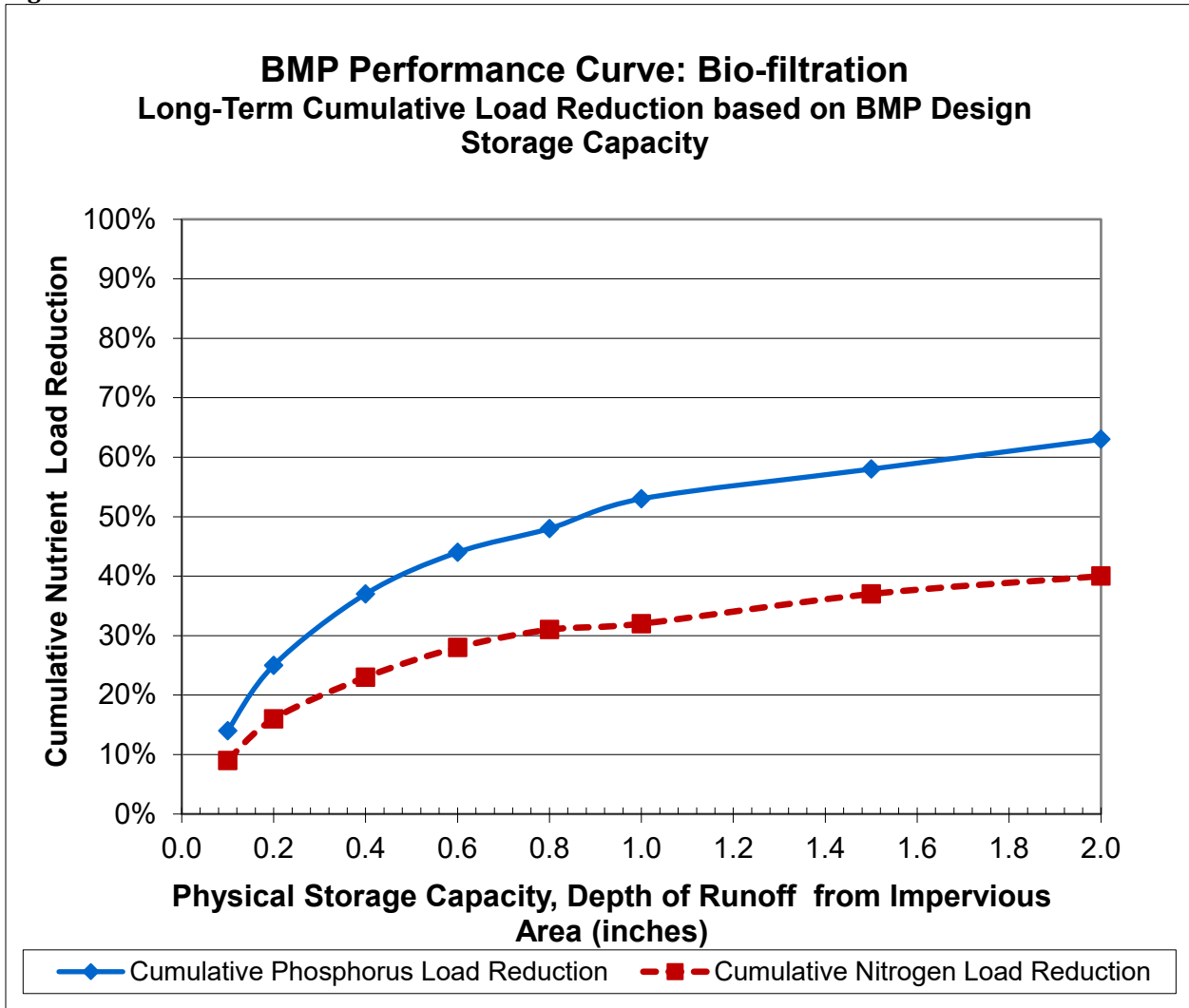
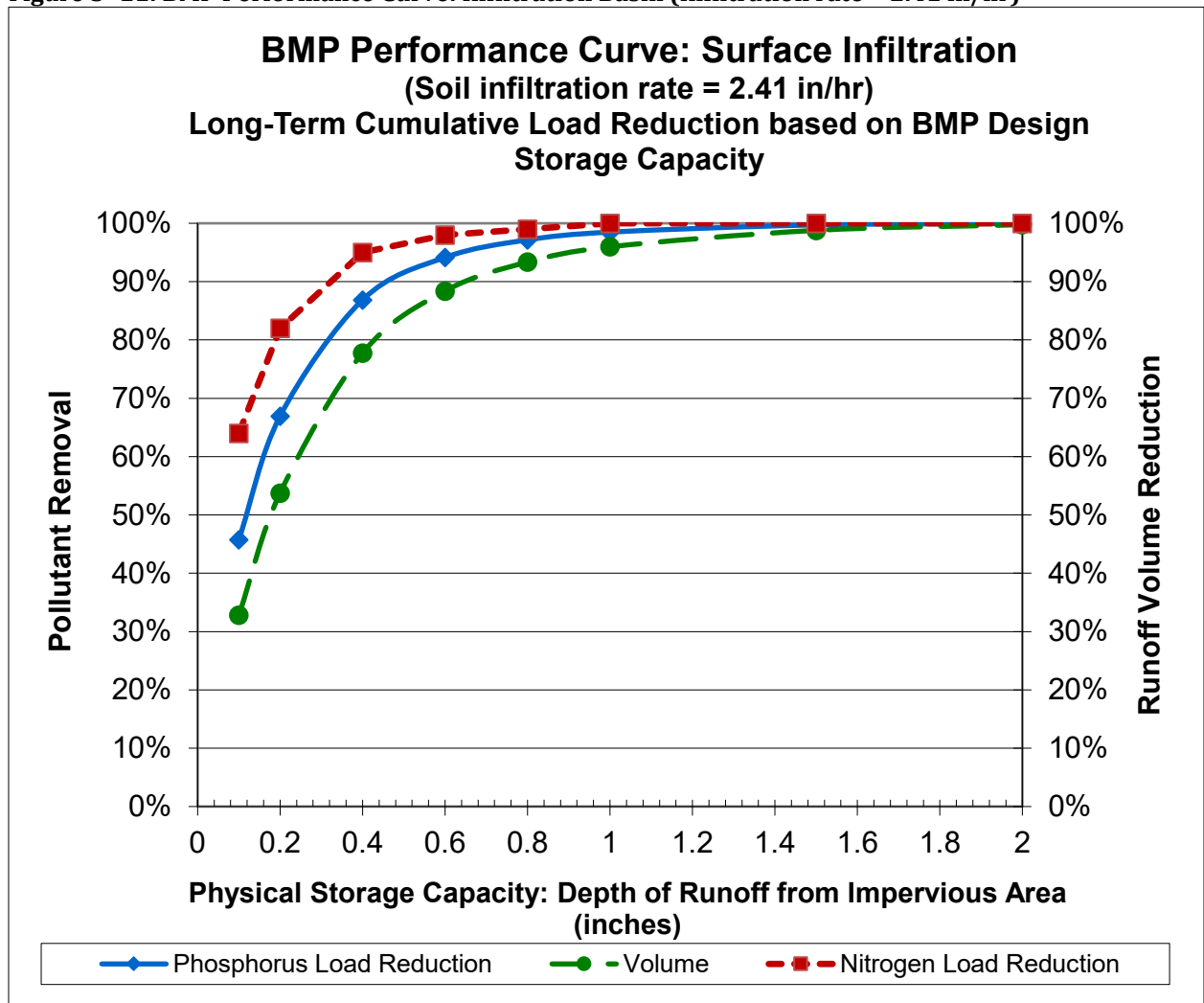

Table 3- 16: Surface Infiltration (2.41 in/hr) BMP Performance Table

Surface Infiltration (2.41 in/hr) BMP Performance Table: Long-Term Phosphorus Load Reduction								
BMP Capacity: Depth of Runoff from Impervious Area (inches)	0.1	0.2	0.4	0.6	0.8	1.0	1.5	2.0
Runoff Volume Reduction	32.8%	53.8%	77.8%	88.4%	93.4%	96.0%	98.8%	99.8%
Cumulative Phosphorus Load Reduction	46%	67%	87%	94%	97%	98%	100%	100%
Cumulative Nitrogen Load Reduction	64%	82%	95%	98%	99%	100%	100%	100%

Figure 3- 11: BMP Performance Curve: Infiltration Basin (infiltration rate = 2.41 in/hr)





STORMTECH ISOLATOR ROW SIZING CHART					
	SC-310	SC-740	DC-780	MC-3500	MC-4500
Chamber Area (Sq.Ft.)	20	27.8	27.8	43.2	30.1
Treated Flow Rate per chamber (CFS)	0.11	0.15	0.15	0.24	0.17

NOTE: Testing of the Isolator Row completed by Tennessee Tech has been verified by NJCAT and it has shown to have a TSS removal efficiency of 84% for SIL-CO-SIL 250
 NJCAT verified Treated Flow Rate (GPM / Sq.Ft.) 2.5

NON-INFILTRATIVE ISOLATOR ROWS

PARKING LOT A

BMP-1 OVERFLOW: 0.43 CFS
 4 SC-310 CHAMBERS

BMP-2 OVERFLOW: 0.70 CFS
 7 SC-310 CHAMBERS

TOTAL: 11 CHAMBERS

PARKING LOT B

BMP-5b OVERFLOW: 0.79 CFS
 8 SC-310 CHAMBERS

PARKING LOT C

BMP-9 OVERFLOW: 1.00 CFS
 10 SC-310 CHAMBERS

SUBSURFACE INFILTRATION SYSTEM ISOLATOR ROWS

SUBSURFACE INFILTRATION SYSTEM #1

1.7-inch WQF: 0.42 cfs
 5 SC-310 Chambers

SUBSURFACE INFILTRATION SYSTEM #2

1.7-inch WQF: 2.62
 18 SC-740 Chambers

SUBSURFACE INFILTRATION SYSTEM #3

1.7-inch WQF: 0.36 cfs
 4 SC-310 Chambers

STANDARD 10: Illicit Discharge Compliance Statement

Project Name: East Beach Green Infrastructure Project	Nitsch Project #: 14850
Location: New Bedford, MA	Checked by: JJ
Prepared by: JW	Sheet No. 1 of 1
Date: 4/5/22	

Standard 10 states: All illicit discharges to the stormwater management system are prohibited.

This is to verify:

1. Based on the information available there are no known or suspected illicit discharges to the stormwater management system at East Beach site in New Bedford, MA as defined in the MassDEP Stormwater Handbook.
2. The design of the stormwater system includes no proposed illicit discharges.

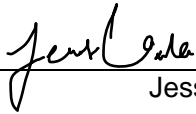

 Jessica Wala, PE

4/5/22

 Date

APPENDIX B

1.7-inch Water Quality Volume Analysis – HydroCAD Calculations

1.7-INCH WATER QUALITY VOLUME ANALYSIS

6/15/22

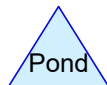
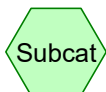
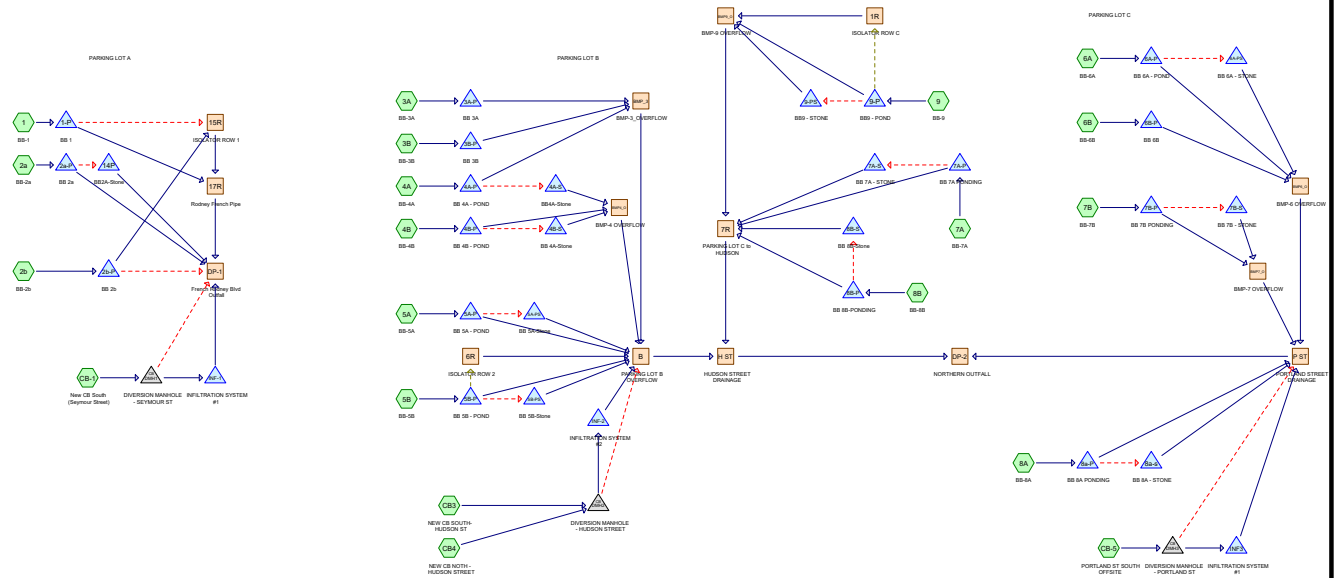

Routing Diagram for 14850_Proposed-Drainage-Areas_220609
 Prepared by {enter your company name here}, Printed 6/16/2022
 HydroCAD® 10.10-7a s/n 00546 © 2021 HydroCAD Software Solutions LLC

14850_Proposed-Drainage-Areas_220609

Prepared by {enter your company name here}

HydroCAD® 10.10-7a s/n 00546 © 2021 HydroCAD Software Solutions LLC

Printed 6/16/2022

Page 2

Rainfall Events Listing (selected events)

Event#	Event Name	Storm Type	Curve	Mode	Duration (hours)	B/B	Depth (inches)	AMC
1	1.7-in	NOAA 24-hr	C	Default	24.00	1	1.70	2

Time span=0.00-72.00 hrs, dt=0.05 hrs, 1441 points
Runoff by SCS TR-20 method, UH=SCS, Weighted-CN
Reach routing by Stor-Ind+Trans method - Pond routing by Stor-Ind method

Pond 1-P: BB 1 Peak Elev=9.90' Storage=630 cf Inflow=0.71 cfs 2,036 cf
Discarded=0.04 cfs 1,515 cf Primary=0.00 cfs 0 cf Secondary=0.23 cfs 521 cf Outflow=0.27 cfs 2,036 cf

Pond 2a-P: BB 2a Peak Elev=8.95' Storage=107 cf Inflow=0.11 cfs 334 cf
Primary=0.00 cfs 0 cf Secondary=0.02 cfs 334 cf Outflow=0.02 cfs 334 cf

Pond 2b-P: BB 2b Peak Elev=8.14' Storage=52 cf Inflow=0.65 cfs 1,868 cf
Primary=0.63 cfs 1,868 cf Secondary=0.00 cfs 0 cf Outflow=0.63 cfs 1,868 cf

Pond 3A-P: BB 3A Peak Elev=10.89' Storage=302 cf Inflow=0.24 cfs 668 cf
Discarded=0.02 cfs 668 cf Primary=0.00 cfs 0 cf Outflow=0.02 cfs 668 cf

Pond 3B-P: BB 3B Peak Elev=12.74' Storage=177 cf Inflow=0.14 cfs 395 cf
Discarded=0.01 cfs 395 cf Primary=0.00 cfs 0 cf Outflow=0.01 cfs 395 cf

Pond 4A-P: BB 4A - POND Peak Elev=9.91' Storage=151 cf Inflow=0.16 cfs 484 cf
Primary=0.00 cfs 0 cf Secondary=0.03 cfs 484 cf Outflow=0.03 cfs 484 cf

Pond 4A-S: BB4A-Stone Peak Elev=7.11' Storage=25 cf Inflow=0.03 cfs 484 cf
Outflow=0.03 cfs 467 cf

Pond 4B-P: BB 4B - POND Peak Elev=10.92' Storage=96 cf Inflow=0.10 cfs 305 cf
Primary=0.00 cfs 0 cf Secondary=0.02 cfs 305 cf Outflow=0.02 cfs 305 cf

Pond 4B-S: BB 4A-Stone Peak Elev=7.84' Storage=15 cf Inflow=0.02 cfs 305 cf
Outflow=0.02 cfs 294 cf

Pond 5A-P: BB 5A - POND Peak Elev=8.89' Storage=45 cf Inflow=0.09 cfs 249 cf
Primary=0.00 cfs 0 cf Secondary=0.03 cfs 249 cf Outflow=0.03 cfs 249 cf

Pond 5A-PS: BB 5A-Stone Peak Elev=5.91' Storage=52 cf Inflow=0.03 cfs 249 cf
Outflow=0.03 cfs 213 cf

Pond 5B-P: BB 5B - POND Peak Elev=8.85' Storage=506 cf Inflow=0.92 cfs 2,623 cf
Primary=0.00 cfs 0 cf Secondary=0.08 cfs 1,755 cf Tertiary=0.69 cfs 868 cf Outflow=0.76 cfs 2,623 cf

Pond 5B-PS: BB 5B-Stone Peak Elev=5.44' Storage=90 cf Inflow=0.08 cfs 1,755 cf
Outflow=0.07 cfs 1,704 cf

Pond 6A-P: BB 6A - POND Peak Elev=10.72' Storage=242 cf Inflow=0.26 cfs 736 cf
Primary=0.00 cfs 0 cf Secondary=0.04 cfs 736 cf Outflow=0.04 cfs 736 cf

Pond 6A-PS: BB 6A - STONE Peak Elev=7.38' Storage=33 cf Inflow=0.04 cfs 736 cf
Outflow=0.04 cfs 714 cf

Pond 6B-P: BB 6B Peak Elev=11.90' Storage=269 cf Inflow=0.20 cfs 564 cf
Discarded=0.02 cfs 564 cf Primary=0.00 cfs 0 cf Outflow=0.02 cfs 564 cf

Pond 7A-P: BB 7A PONDING	Peak Elev=9.84' Storage=108 cf Inflow=0.11 cfs 316 cf Primary=0.00 cfs 0 cf Secondary=0.02 cfs 316 cf Outflow=0.02 cfs 316 cf
Pond 7A-S: BB 7A - STONE	Peak Elev=5.18' Storage=4 cf Inflow=0.02 cfs 316 cf Outflow=0.02 cfs 316 cf
Pond 7B-P: BB 7B PONDING	Peak Elev=10.47' Storage=162 cf Inflow=0.17 cfs 494 cf Primary=0.00 cfs 0 cf Secondary=0.03 cfs 494 cf Outflow=0.03 cfs 494 cf
Pond 7B-S: BB 7B - STONE	Peak Elev=7.61' Storage=16 cf Inflow=0.03 cfs 494 cf Outflow=0.03 cfs 483 cf
Pond 8a-P: BB 8A PONDING	Peak Elev=8.71' Storage=87 cf Inflow=0.12 cfs 346 cf Primary=0.00 cfs 0 cf Secondary=0.03 cfs 346 cf Outflow=0.03 cfs 346 cf
Pond 8a-s: BB 8A - STONE	Peak Elev=5.61' Storage=28 cf Inflow=0.03 cfs 346 cf Outflow=0.03 cfs 328 cf
Pond 8B-P: BB 8B-PONDING	Peak Elev=9.60' Storage=186 cf Inflow=0.19 cfs 559 cf Primary=0.00 cfs 0 cf Secondary=0.03 cfs 559 cf Outflow=0.03 cfs 559 cf
Pond 8B-S: BB 8B-Stone	Peak Elev=6.32' Storage=38 cf Inflow=0.03 cfs 559 cf Outflow=0.03 cfs 532 cf
Pond 9-P: BB9 - POND	Peak Elev=8.66' Storage=253 cf Inflow=0.84 cfs 2,402 cf Primary=0.00 cfs 0 cf Secondary=0.04 cfs 1,207 cf Tertiary=0.77 cfs 1,195 cf Outflow=0.81 cfs 2,402 cf
Pond 9-PS: BB9 - STONE	Peak Elev=5.38' Storage=21 cf Inflow=0.04 cfs 1,207 cf Outflow=0.04 cfs 1,193 cf
Pond 14P: BB2A-Stone	Peak Elev=5.59' Storage=5 cf Inflow=0.02 cfs 334 cf Outflow=0.02 cfs 334 cf
Pond DMH1: DIVERSION MANHOLE - SEYMOUR ST	Peak Elev=9.36' Inflow=0.42 cfs 1,191 cf Primary=0.31 cfs 1,130 cf Secondary=0.11 cfs 61 cf Outflow=0.42 cfs 1,191 cf
Pond DMH2: DIVERSION MANHOLE - HUDSON STREET	Peak Elev=11.81' Inflow=2.62 cfs 7,514 cf Primary=0.93 cfs 6,224 cf Secondary=1.70 cfs 1,290 cf Outflow=2.62 cfs 7,514 cf
Pond DMH3: DIVERSION MANHOLE - PORTLANDST	Peak Elev=11.31' Inflow=0.36 cfs 1,035 cf Primary=0.31 cfs 1,012 cf Secondary=0.05 cfs 23 cf Outflow=0.36 cfs 1,035 cf
Pond INF-1: INFILTRATIONSYSTEM #1	Peak Elev=8.33' Storage=364 cf Inflow=0.31 cfs 1,130 cf Discarded=0.05 cfs 1,130 cf Primary=0.00 cfs 0 cf Outflow=0.05 cfs 1,130 cf
Pond INF-2: INFILTRATIONSYSTEM #2	Peak Elev=9.46' Storage=2,921 cf Inflow=0.93 cfs 6,224 cf Discarded=0.11 cfs 6,224 cf Primary=0.00 cfs 0 cf Outflow=0.11 cfs 6,224 cf
Pond INF3: INFILTRATIONSYSTEM #1	Peak Elev=8.82' Storage=385 cf Inflow=0.31 cfs 1,012 cf Discarded=0.04 cfs 1,012 cf Primary=0.00 cfs 0 cf Outflow=0.04 cfs 1,012 cf

Summary for Pond 1-P: BB 1

Inflow Area = 38,826 sf, 51.66% Impervious, Inflow Depth = 0.63" for 1.7-in event
 Inflow = 0.71 cfs @ 12.14 hrs, Volume= 2,036 cf
 Outflow = 0.27 cfs @ 12.33 hrs, Volume= 2,036 cf, Atten= 63%, Lag= 11.6 min
 Discarded = 0.04 cfs @ 12.33 hrs, Volume= 1,515 cf
 Primary = 0.00 cfs @ 0.00 hrs, Volume= 0 cf
 Routed to Reach 17R : Rodney French Pipe
 Secondary = 0.23 cfs @ 12.33 hrs, Volume= 521 cf
 Routed to Reach 15R : ISOLATOR ROW 1

INFILTRATION

NO UNTREATED OVERFLOW

ALL OVERFLOW TO ISOLATOR ROW

Routing by Stor-Ind method, Time Span= 0.00-72.00 hrs, dt= 0.05 hrs
 Peak Elev= 9.90' @ 12.33 hrs Surf.Area= 1,388 sf Storage= 630 cf

Plug-Flow detention time= 155.8 min calculated for 2,034 cf (100% of inflow)
 Center-of-Mass det. time= 155.8 min (1,013.2 - 857.3)

Volume	Invert	Avail.Storage	Storage Description
#1	9.20'	1,114 cf	Custom Stage Data (Prismatic) Listed below (Recalc)

Elevation (feet)	Surf.Area (sq-ft)	Inc.Store (cubic-feet)	Cum.Store (cubic-feet)
9.20	490	0	0
9.50	800	194	194
10.20	1,830	920	1,114

Device	Routing	Invert	Outlet Devices
#1	Primary	8.00'	12.0" Round Culvert L= 10.0' CPP, square edge headwall, Ke= 0.500 Inlet / Outlet Invert= 8.00' / 7.90' S= 0.0100 '/ Cc= 0.900 n= 0.013, Flow Area= 0.79 sf
#2	Discarded	9.20'	1.020 in/hr Exfiltration over Surface area Conductivity to Groundwater Elevation = 6.00'
#3	Device 1	10.00'	24inch-Dome Grate Capacity X 2.00
#4	Secondary	9.83'	15inch-Dome Grate Capacity

Discarded OutFlow Max=0.04 cfs @ 12.33 hrs HW=9.90' (Free Discharge)
 ↑2=Exfiltration (Controls 0.04 cfs)

Primary OutFlow Max=0.00 cfs @ 0.00 hrs HW=9.20' (Free Discharge)
 ↑1=Culvert (Passes 0.00 cfs of 2.86 cfs potential flow)
 ↑3=24inch-Dome Grate Capacity (Controls 0.00 cfs)

Secondary OutFlow Max=0.23 cfs @ 12.33 hrs HW=9.90' (Free Discharge)
 ↑4=15inch-Dome Grate Capacity (Custom Controls 0.23 cfs)

Summary for Pond 2a-P: BB 2a

Inflow Area = 3,116 sf, 92.62% Impervious, Inflow Depth = 1.29" for 1.7-in event
 Inflow = 0.11 cfs @ 12.13 hrs, Volume= 334 cf
 Outflow = 0.02 cfs @ 12.60 hrs, Volume= 334 cf, Atten= 84%, Lag= 28.3 min
 Primary = 0.00 cfs @ 0.00 hrs, Volume= 0 cf
 Routed to Reach DP-1 : French Rodney Blvd Outfall
 Secondary = 0.02 cfs @ 12.60 hrs, Volume= 334 cf
 Routed to Pond 14P : BB2A-Stone

NO OVERFLOW

FLOW THROUGH
 BIORETENTION
 TREATMENT SECTION

Routing by Stor-Ind method, Time Span= 0.00-72.00 hrs, dt= 0.05 hrs
 Peak Elev= 8.95' @ 12.60 hrs Surf.Area= 300 sf Storage= 107 cf

Plug-Flow detention time= 46.0 min calculated for 334 cf (100% of inflow)
 Center-of-Mass det. time= 46.0 min (842.6 - 796.7)

Volume	Invert	Avail.Storage	Storage Description
#1	8.50'	462 cf	Custom Stage Data (Prismatic) Listed below (Recalc)

Elevation (feet)	Surf.Area (sq-ft)	Inc.Store (cubic-feet)	Cum.Store (cubic-feet)
8.50	180	0	0
9.80	530	462	462

Device	Routing	Invert	Outlet Devices
#1	Primary	7.80'	10.0" Round Culvert L= 10.0' CPP, square edge headwall, Ke= 0.500 Inlet / Outlet Invert= 7.80' / 7.70' S= 0.0100 '/ Cc= 0.900 n= 0.013, Flow Area= 0.55 sf
#2	Device 1	9.30'	24inch-Dome Grate Capacity
#3	Secondary	8.50'	2.410 in/hr Exfiltration over Surface area Conductivity to Groundwater Elevation = 4.60'

Primary OutFlow Max=0.00 cfs @ 0.00 hrs HW=8.50' (Free Discharge)

- ↑1=Culvert (Passes 0.00 cfs of 1.12 cfs potential flow)
- ↑2=24inch-Dome Grate Capacity (Controls 0.00 cfs)

Secondary OutFlow Max=0.02 cfs @ 12.60 hrs HW=8.95' (Free Discharge)

- ↑3=Exfiltration (Controls 0.02 cfs)

Summary for Pond 2b-P: BB 2b

Inflow Area = 21,490 sf, 80.50% Impervious, Inflow Depth = 1.04" for 1.7-in event
 Inflow = 0.65 cfs @ 12.13 hrs, Volume= 1,868 cf
 Outflow = 0.63 cfs @ 12.15 hrs, Volume= 1,868 cf, Atten= 3%, Lag= 1.0 min
 Primary = 0.63 cfs @ 12.15 hrs, Volume= 1,868 cf
 Routed to Reach 15R : ISOLATOR ROW 1
 Secondary = 0.00 cfs @ 0.00 hrs, Volume= 0 cf
 Routed to Reach DP-1 : French Rodney Blvd Outfall

NO OVERFLOW TO
CLOSE DRAINAGE
SYSTEM

ALL OVERFLOW TO
ISOLATOR ROW

Routing by Stor-Ind method, Time Span= 0.00-72.00 hrs, dt= 0.05 hrs
 Peak Elev= 8.14' @ 12.15 hrs Surf.Area= 428 sf Storage= 52 cf

Plug-Flow detention time= 2.0 min calculated for 1,866 cf (100% of inflow)
 Center-of-Mass det. time= 2.0 min (821.8 - 819.8)

Volume	Invert	Avail.Storage	Storage Description
#1	8.00'	710 cf	Custom Stage Data (Prismatic) Listed below (Recalc)

Elevation (feet)	Surf.Area (sq-ft)	Inc.Store (cubic-feet)	Cum.Store (cubic-feet)
8.00	320	0	0
9.00	1,100	710	710

Device	Routing	Invert	Outlet Devices
#1	Secondary	7.00'	12.0" Round Culvert L= 10.0' CPP, square edge headwall, Ke= 0.500 Inlet / Outlet Invert= 7.00' / 6.90' S= 0.0100 '/ Cc= 0.900 n= 0.013, Flow Area= 0.79 sf
#2	Device 1	8.50'	24inch-Dome Grate Capacity X 2.00
#3	Primary	8.00'	15inch-Dome Grate Capacity

Primary OutFlow Max=0.63 cfs @ 12.15 hrs HW=8.14' (Free Discharge)
 ↑3=15inch-Dome Grate Capacity (Custom Controls 0.63 cfs)

Secondary OutFlow Max=0.00 cfs @ 0.00 hrs HW=8.00' (Free Discharge)
 ↑1=Culvert (Passes 0.00 cfs of 2.27 cfs potential flow)
 ↑2=24inch-Dome Grate Capacity (Controls 0.00 cfs)

Summary for Pond 3A-P: BB 3A

Inflow Area = 10,987 sf, 58.16% Impervious, Inflow Depth = 0.73" for 1.7-in event
 Inflow = 0.24 cfs @ 12.13 hrs, Volume= 668 cf
 Outflow = 0.02 cfs @ 13.36 hrs, Volume= 668 cf, Atten= 92%, Lag= 73.4 min
 Discarded = 0.02 cfs @ 13.36 hrs, Volume= 668 cf
 Primary = 0.00 cfs @ 0.00 hrs, Volume= 0 cf

INFILTRATION

NO OVERFLOW

Routed to Reach BMP_3 : BMP-3_OVERFLOW

Routing by Stor-Ind method, Time Span= 0.00-72.00 hrs, dt= 0.05 hrs
 Peak Elev= 10.89' @ 13.36 hrs Surf.Area= 737 sf Storage= 302 cf

Plug-Flow detention time= 183.8 min calculated for 668 cf (100% of inflow)
 Center-of-Mass det. time= 183.8 min (1,031.3 - 847.5)

Volume	Invert	Avail.Storage	Storage Description
#1	10.25'	622 cf	Custom Stage Data (Prismatic) Listed below (Recalc)
Elevation (feet)	Surf.Area (sq-ft)	Inc.Store (cubic-feet)	Cum.Store (cubic-feet)
10.25	271	0	0
10.45	350	62	62
11.25	1,050	560	622

Device	Routing	Invert	Outlet Devices
#1	Primary	9.30'	10.0" Round Culvert L= 10.0' CPP, square edge headwall, Ke= 0.500 Inlet / Outlet Invert= 9.30' / 9.20' S= 0.0100 '/ Cc= 0.900 n= 0.013, Flow Area= 0.55 sf
#2	Discarded	10.25'	1.020 in/hr Exfiltration over Surface area Conductivity to Groundwater Elevation = 7.30'
#3	Primary	11.15'	5.0' long Sharp-Crested Rectangular Weir 2 End Contraction(s)
#4	Device 1	10.90'	24inch-Dome Grate Capacity

Discarded OutFlow Max=0.02 cfs @ 13.36 hrs HW=10.89' (Free Discharge)
 ↑ **2=Exfiltration** (Controls 0.02 cfs)

Primary OutFlow Max=0.00 cfs @ 0.00 hrs HW=10.25' (Free Discharge)
 ↑ **1=Culvert** (Passes 0.00 cfs of 1.72 cfs potential flow)
 ↑ **4=24inch-Dome Grate Capacity** (Controls 0.00 cfs)
 ↑ **3=Sharp-Crested Rectangular Weir** (Controls 0.00 cfs)

Summary for Pond 3B-P: BB 3B

Inflow Area = 4,545 sf, 77.34% Impervious, Inflow Depth = 1.04" for 1.7-in event
 Inflow = 0.14 cfs @ 12.13 hrs, Volume= 395 cf
 Outflow = 0.01 cfs @ 13.11 hrs, Volume= 395 cf, Atten= 91%, Lag= 59.0 min
 Discarded = 0.01 cfs @ 13.11 hrs, Volume= 395 cf
 Primary = 0.00 cfs @ 0.00 hrs, Volume= 0 cf

INFILTRATION

NO OVERFLOW

Routed to Reach BMP_3 : BMP-3_OVERFLOW

Routing by Stor-Ind method, Time Span= 0.00-72.00 hrs, dt= 0.05 hrs
 Peak Elev= 12.74' @ 13.11 hrs Surf.Area= 479 sf Storage= 177 cf

Plug-Flow detention time= 150.1 min calculated for 395 cf (100% of inflow)
 Center-of-Mass det. time= 150.1 min (969.8 - 819.8)

Volume	Invert	Avail.Storage	Storage Description
#1	12.20'	263 cf	Custom Stage Data (Prismatic) Listed below (Recalc)
Elevation (feet)	Surf.Area (sq-ft)	Inc.Store (cubic-feet)	Cum.Store (cubic-feet)
12.20	180	0	0
12.90	570	263	263

Device	Routing	Invert	Outlet Devices
#1	Primary	10.70'	10.0" Round Culvert L= 10.0' CPP, square edge headwall, Ke= 0.500 Inlet / Outlet Invert= 10.70' / 10.60' S= 0.0100 '/' Cc= 0.900 n= 0.013, Flow Area= 0.55 sf
#2	Discarded	12.20'	1.020 in/hr Exfiltration over Surface area Conductivity to Groundwater Elevation = 8.70'
#3	Device 1	12.80'	24inch-Dome Grate Capacity
#4	Primary	12.85'	5.0' long Sharp-Crested Rectangular Weir 2 End Contraction(s)

Discarded OutFlow Max=0.01 cfs @ 13.11 hrs HW=12.74' (Free Discharge)
 ↑ **2=Exfiltration** (Controls 0.01 cfs)

Primary OutFlow Max=0.00 cfs @ 0.00 hrs HW=12.20' (Free Discharge)
 ↑ **1=Culvert** (Passes 0.00 cfs of 2.73 cfs potential flow)
 ↑ **3=24inch-Dome Grate Capacity** (Controls 0.00 cfs)
 ↑ **4=Sharp-Crested Rectangular Weir** (Controls 0.00 cfs)

Summary for Pond 4A-P: BB 4A - POND

Inflow Area = 4,843 sf, 86.37% Impervious, Inflow Depth = 1.20" for 1.7-in event
 Inflow = 0.16 cfs @ 12.13 hrs, Volume= 484 cf
 Outflow = 0.03 cfs @ 12.58 hrs, Volume= 484 cf, Atten= 82%, Lag= 26.8 min
 Primary = 0.00 cfs @ 0.00 hrs, Volume= 0 cf
 Routed to Reach BMP 3 : BMP-3 OVERFLOW
 Secondary = 0.03 cfs @ 12.58 hrs, Volume= 484 cf
 Routed to Pond 4A-S : BB4A-Stone

NO OVERFLOW

FLOW THROUGH
 BIORETENTION
 TREATMENT SECTION

Routing by Stor-Ind method, Time Span= 0.00-72.00 hrs, dt= 0.05 hrs
 Peak Elev= 9.91' @ 12.58 hrs Surf.Area= 491 sf Storage= 151 cf

Plug-Flow detention time= 40.5 min calculated for 484 cf (100% of inflow)
 Center-of-Mass det. time= 40.5 min (845.9 - 805.4)

Volume	Invert	Avail.Storage	Storage Description
#1	9.50'	320 cf	Custom Stage Data (Prismatic) Listed below (Recalc)

Elevation (feet)	Surf.Area (sq-ft)	Inc.Store (cubic-feet)	Cum.Store (cubic-feet)
9.50	250	0	0
10.20	664	320	320

Device	Routing	Invert	Outlet Devices
#1	Primary	8.00'	12.0" Round Culvert L= 10.0' CPP, square edge headwall, Ke= 0.500 Inlet / Outlet Invert= 8.00' / 7.90' S= 0.0100 '/ Cc= 0.900 n= 0.013, Flow Area= 0.79 sf
#2	Secondary	9.50'	2.410 in/hr Exfiltration over Surface area Conductivity to Groundwater Elevation = 6.00'
#3	Primary	10.10'	5.0' long Sharp-Crested Rectangular Weir 2 End Contraction(s)
#4	Device 1	9.95'	24inchDome Grate Capacity Head (feet) 0.00 0.05 0.10 0.15 0.20 0.25 0.30 0.35 0.40 0.45 0.50 0.55 0.60 0.65 0.70 0.75 0.80 0.85 0.90 0.95 1.00 1.05 1.10 Disch. (cfs) 0.000 0.180 0.460 0.850 1.360 1.830 2.420 3.100 3.600 3.800 4.000 4.200 4.380 4.600 4.750 4.900 5.100 5.200 5.350 5.450 5.650 5.800 5.950

Primary OutFlow Max=0.00 cfs @ 0.00 hrs HW=9.50' (Free Discharge)

- 1=Culvert (Passes 0.00 cfs of 3.62 cfs potential flow)
- 4=24inchDome Grate Capacity (Controls 0.00 cfs)
- 3=Sharp-Crested Rectangular Weir(Controls 0.00 cfs)

Secondary OutFlow Max=0.03 cfs @ 12.58 hrs HW=9.91' (Free Discharge)

- 2=Exfiltration (Controls 0.03 cfs)

Summary for Pond 4A-S: BB4A-Stone

Inflow = 0.03 cfs @ 12.58 hrs, Volume= 484 cf
 Outflow = 0.03 cfs @ 12.61 hrs, Volume= 467 cf, Atten= 0%, Lag= 2.1 min
 Primary = 0.03 cfs @ 12.61 hrs, Volume= 467 cf
 Routed to Reach BMP4_O : BMP-4 OVERFLOW

Routing by Stor-Ind method, Time Span= 0.00-72.00 hrs, dt= 0.05 hrs
 Peak Elev= 7.11' @ 12.61 hrs Surf.Area= 230 sf Storage= 25 cf

Plug-Flow detention time= 39.5 min calculated for 467 cf (96% of inflow)
 Center-of-Mass det. time= 19.6 min (865.4 - 845.9)

Volume	Invert	Avail.Storage	Storage Description
#1	6.75'	138 cf	Custom Stage Data (Prismatic) Listed below (Recalc) 460 cf Overall x 30.0% Voids

Elevation (feet)	Surf.Area (sq-ft)	Inc.Store (cubic-feet)	Cum.Store (cubic-feet)
6.75	230	0	0
8.75	230	460	460

Device	Routing	Invert	Outlet Devices
#1	Primary	7.00'	4.0" Vert. Orifice/Grate C= 0.600 Limited to weir flow at low heads

Primary OutFlow Max=0.03 cfs @ 12.61 hrs HW=7.11' (Free Discharge)
 ↑1=Orifice/Grate (Orifice Controls 0.03 cfs @ 1.14 fps)

Summary for Pond 4B-P: BB 4B - POND

Inflow Area = 3,048 sf, 86.09% Impervious, Inflow Depth = 1.20" for 1.7-in event
 Inflow = 0.10 cfs @ 12.13 hrs, Volume= 305 cf
 Outflow = 0.02 cfs @ 12.57 hrs, Volume= 305 cf, Atten= 82%, Lag= 26.6 min
 Primary = 0.00 cfs @ 0.00 hrs, Volume= 0 cf
 Routed to Reach BMP4 O : BMP-4 OVERFLOW
 Secondary = 0.02 cfs @ 12.57 hrs, Volume= 305 cf
 Routed to Pond 4B-S : BB 4A-Stone

NO OVERFLOW

FLOW THROUGH
 BIORETENTION
 TREATMENT SECTION

Routing by Stor-Ind method, Time Span= 0.00-72.00 hrs, dt= 0.05 hrs
 Peak Elev= 10.92' @ 12.57 hrs Surf.Area= 312 sf Storage= 96 cf

Plug-Flow detention time= 41.2 min calculated for 305 cf (100% of inflow)
 Center-of-Mass det. time= 41.2 min (846.6 - 805.4)

Volume	Invert	Avail.Storage	Storage Description
#1	10.50'	199 cf	Custom Stage Data (Prismatic) Listed below (Recalc)

Elevation (feet)	Surf.Area (sq-ft)	Inc.Store (cubic-feet)	Cum.Store (cubic-feet)
10.50	144	0	0
11.20	424	199	199

Device	Routing	Invert	Outlet Devices
#1	Primary	9.00'	12.0" Round Culvert L= 10.0' CPP, square edge headwall, Ke= 0.500 Inlet / Outlet Invert= 9.00' / 8.90' S= 0.0100 '/ Cc= 0.900 n= 0.013, Flow Area= 0.79 sf
#2	Secondary	10.50'	2.410 in/hr Exfiltration over Surface area Conductivity to Groundwater Elevation = 7.00'
#3	Primary	11.10'	5.0' long Sharp-Crested Rectangular Weir 2 End Contraction(s)
#4	Device 1	10.95'	24inch-Dome Grate Capacity

Primary OutFlow Max=0.00 cfs @ 0.00 hrs HW=10.50' (Free Discharge)

- 1=Culvert (Passes 0.00 cfs of 3.62 cfs potential flow)
- 4=24inch-Dome Grate Capacity (Controls 0.00 cfs)
- 3=Sharp-Crested Rectangular Weir (Controls 0.00 cfs)

Secondary OutFlow Max=0.02 cfs @ 12.57 hrs HW=10.92' (Free Discharge)

- 2=Exfiltration (Controls 0.02 cfs)

Summary for Pond 4B-S: BB 4A-Stone

Inflow = 0.02 cfs @ 12.57 hrs, Volume= 305 cf
 Outflow = 0.02 cfs @ 12.60 hrs, Volume= 294 cf, Atten= 0%, Lag= 1.8 min
 Primary = 0.02 cfs @ 12.60 hrs, Volume= 294 cf
 Routed to Reach BMP4_O : BMP-4 OVERFLOW

Routing by Stor-Ind method, Time Span= 0.00-72.00 hrs, dt= 0.05 hrs
 Peak Elev= 7.84' @ 12.60 hrs Surf.Area= 145 sf Storage= 15 cf

Plug-Flow detention time= 37.5 min calculated for 293 cf (96% of inflow)
 Center-of-Mass det. time= 18.0 min (864.6 - 846.6)

Volume	Invert	Avail.Storage	Storage Description
#1	7.50'	87 cf	Custom Stage Data (Prismatic) Listed below (Recalc) 290 cf Overall x 30.0% Voids

Elevation (feet)	Surf.Area (sq-ft)	Inc.Store (cubic-feet)	Cum.Store (cubic-feet)
7.50	145	0	0
9.50	145	290	290

Device	Routing	Invert	Outlet Devices
#1	Primary	7.75'	4.0" Vert. Orifice/Grate C= 0.600 Limited to weir flow at low heads

Primary OutFlow Max=0.02 cfs @ 12.60 hrs HW=7.84' (Free Discharge)
 ↑1=Orifice/Grate (Orifice Controls 0.02 cfs @ 1.01 fps)

Summary for Pond 5A-P: BB 5A - POND

Inflow Area = 3,072 sf, 73.44% Impervious, Inflow Depth = 0.97" for 1.7-in event
 Inflow = 0.09 cfs @ 12.13 hrs, Volume= 249 cf
 Outflow = 0.03 cfs @ 12.33 hrs, Volume= 249 cf, Atten= 66%, Lag= 12.1 min
 Primary = 0.00 cfs @ 0.00 hrs, Volume= 0 cf
 Routed to Reach B : PARKING LOT B OVERFLOW
 Secondary = 0.03 cfs @ 12.33 hrs, Volume= 249 cf
 Routed to Pond 5A-PS : BB 5A-Stone

NO OVERFLOW

FLOW THROUGH
 BIORETENTION
 TREATMENT SECTION

Routing by Stor-Ind method, Time Span= 0.00-72.00 hrs, dt= 0.05 hrs
 Peak Elev= 8.89' @ 12.33 hrs Surf.Area= 510 sf Storage= 45 cf

Plug-Flow detention time= 10.7 min calculated for 249 cf (100% of inflow)
 Center-of-Mass det. time= 10.7 min (836.7 - 826.0)

Volume	Invert	Avail.Storage	Storage Description
#1	8.80'	645 cf	Custom Stage Data (Prismatic) Listed below (Recalc)

Elevation (feet)	Surf.Area (sq-ft)	Inc.Store (cubic-feet)	Cum.Store (cubic-feet)
8.80	480	0	0
9.80	810	645	645

Device	Routing	Invert	Outlet Devices
#1	Primary	7.60'	12.0" Round Culvert L= 10.0' CPP, square edge headwall, Ke= 0.500 Inlet / Outlet Invert= 7.60' / 7.50' S= 0.0100 '/ Cc= 0.900 n= 0.013, Flow Area= 0.79 sf
#2	Secondary	8.80'	2.410 in/hr Exfiltration over Surface area Conductivity to Groundwater Elevation = 5.60'
#3	Device 1	9.50'	24inch-Dome Grate Capacity

Primary OutFlow Max=0.00 cfs @ 0.00 hrs HW=8.80' (Free Discharge)

- ↑1=Culvert (Passes 0.00 cfs of 2.86 cfs potential flow)
- ↑3=24inch-Dome Grate Capacity (Controls 0.00 cfs)

Secondary OutFlow Max=0.03 cfs @ 12.33 hrs HW=8.89' (Free Discharge)

- ↑2=Exfiltration (Controls 0.03 cfs)

Summary for Pond 5A-PS: BB 5A-Stone

Inflow = 0.03 cfs @ 12.33 hrs, Volume= 249 cf
 Outflow = 0.03 cfs @ 12.51 hrs, Volume= 213 cf, Atten= 1%, Lag= 10.8 min
 Primary = 0.03 cfs @ 12.51 hrs, Volume= 213 cf
 Routed to Reach B : PARKING LOT B OVERFLOW

Routing by Stor-Ind method, Time Span= 0.00-72.00 hrs, dt= 0.05 hrs
 Peak Elev= 5.91' @ 12.51 hrs Surf.Area= 480 sf Storage= 52 cf

Plug-Flow detention time= 111.9 min calculated for 213 cf (85% of inflow)
 Center-of-Mass det. time= 47.0 min (883.7 - 836.7)

Volume	Invert	Avail.Storage	Storage Description
#1	5.55'	288 cf	Custom Stage Data (Prismatic) Listed below (Recalc) 960 cf Overall x 30.0% Voids

Elevation (feet)	Surf.Area (sq-ft)	Inc.Store (cubic-feet)	Cum.Store (cubic-feet)
5.55	480	0	0
7.55	480	960	960

Device	Routing	Invert	Outlet Devices
#1	Primary	5.80'	4.0" Vert. Orifice/Grate C= 0.600 Limited to weir flow at low heads

Primary OutFlow Max=0.03 cfs @ 12.51 hrs HW=5.91' (Free Discharge)
 ↑1=Orifice/Grate (Orifice Controls 0.03 cfs @ 1.14 fps)

Summary for Pond 5B-P: BB 5B - POND

Inflow Area = 34,755 sf, 71.39% Impervious, Inflow Depth = 0.91" for 1.7-in event
 Inflow = 0.92 cfs @ 12.13 hrs, Volume= 2,623 cf
 Outflow = 0.76 cfs @ 12.18 hrs, Volume= 2,623 cf, Atten= 17%, Lag= 2.9 min

Primary	=	0.00 cfs @ 0.00 hrs, Volume=	0 cf
Routed to Reach B : PARKING LOT B OVERFLOW			
Secondary	=	0.08 cfs @ 12.18 hrs, Volume=	1,755 cf
Routed to Pond 5B-PS : BB 5B-Stone			
Tertiary	=	0.69 cfs @ 12.18 hrs, Volume=	868 cf
Routed to Reach 6R : ISOLATOR ROW 2			

NO OVERFLOW

FLOW THROUGH
 BIORETENTION
 TREATMENT SECTION

OVERFLOW TO
 ISOLATOR ROW FOR
 TREATMENT

Routing by Stor-Ind method, Time Span= 0.00-72.00 hrs, dt= 0.05 hrs
 Peak Elev= 8.85' @ 12.18 hrs Surf.Area= 1,236 sf Storage= 506 cf

Plug-Flow detention time= 38.5 min calculated for 2,622 cf (100% of inflow)
 Center-of-Mass det. time= 38.5 min (870.3 - 831.8)

Volume	Invert	Avail.Storage	Storage Description
#1	8.20'	711 cf	Custom Stage Data (Prismatic) Listed below (Recalc)
Elevation (feet)	Surf.Area (sq-ft)	Inc.Store (cubic-feet)	Cum.Store (cubic-feet)
8.20	327	0	0
9.00	1,450	711	711

Device	Routing	Invert	Outlet Devices
#1	Primary	7.00'	12.0" Round Culvert L= 10.0' CPP, square edge headwall, Ke= 0.500 Inlet / Outlet Invert= 7.00' / 6.90' S= 0.0100 '/' Cc= 0.900 n= 0.013, Flow Area= 0.79 sf
#2	Secondary	8.20'	2.410 in/hr Exfiltration over Surface area Conductivity to Groundwater Elevation = 5.00'
#3	Device 1	8.90'	24inch Dome Grate Capacity X 2.00 Head (feet) 0.00 0.05 0.10 0.15 0.20 0.25 0.30 0.35 0.40 0.45 0.50 0.55 0.60 0.65 0.70 0.75 0.80 0.85 0.90 0.95 1.00 1.05 1.10 Disch. (cfs) 0.000 0.180 0.460 0.850 1.360 1.830 2.420 3.100 3.600 3.800 4.000 4.200 4.380 4.600 4.750 4.900 5.100 5.200 5.350 5.450 5.650 5.800 5.950
#4	Tertiary	8.70'	15inch-Dome Grate Capacity

Primary OutFlow Max=0.00 cfs @ 0.00 hrs HW=8.20' (Free Discharge)
 ↑1=Culvert (Passes 0.00 cfs of 2.86 cfs potential flow)
 ↑3=24inch Dome Grate Capacity (Controls 0.00 cfs)

Secondary OutFlow Max=0.08 cfs @ 12.18 hrs HW=8.84' (Free Discharge)
 ↑2=Exfiltration (Controls 0.08 cfs)

Tertiary OutFlow Max=0.67 cfs @ 12.18 hrs HW=8.84' (Free Discharge)
 ↑4=15inch-Dome Grate Capacity (Custom Controls 0.67 cfs)

Summary for Pond 5B-PS: BB 5B-Stone

Inflow = 0.08 cfs @ 12.18 hrs, Volume= 1,755 cf
 Outflow = 0.07 cfs @ 12.28 hrs, Volume= 1,704 cf, Atten= 4%, Lag= 5.7 min
 Primary = 0.07 cfs @ 12.28 hrs, Volume= 1,704 cf
 Routed to Reach B : PARKING LOT B OVERFLOW

Routing by Stor-Ind method, Time Span= 0.00-72.00 hrs, dt= 0.05 hrs
 Peak Elev= 5.44' @ 12.28 hrs Surf.Area= 690 sf Storage= 90 cf

Plug-Flow detention time= 36.9 min calculated for 1,703 cf (97% of inflow)
 Center-of-Mass det. time= 22.5 min (955.9 - 933.4)

Volume	Invert	Avail.Storage	Storage Description
#1	5.00'	414 cf	Custom Stage Data (Prismatic) Listed below (Recalc) 1,380 cf Overall x 30.0% Voids

Elevation (feet)	Surf.Area (sq-ft)	Inc.Store (cubic-feet)	Cum.Store (cubic-feet)
5.00	690	0	0
7.00	690	1,380	1,380

Device	Routing	Invert	Outlet Devices
#1	Primary	5.25'	4.0" Vert. Orifice/Grate C= 0.600 Limited to weir flow at low heads

Primary OutFlow Max=0.07 cfs @ 12.28 hrs HW=5.44' (Free Discharge)
 ↑1=Orifice/Grate (Orifice Controls 0.07 cfs @ 1.47 fps)

Summary for Pond 6A-P: BB 6A - POND

Inflow Area = 15,148 sf, 46.97% Impervious, Inflow Depth = 0.58" for 1.7-in event
 Inflow = 0.26 cfs @ 12.14 hrs, Volume= 736 cf
 Outflow = 0.04 cfs @ 12.87 hrs, Volume= 736 cf, Atten= 86%, Lag= 44.1 min
 Primary = 0.00 cfs @ 0.00 hrs, Volume= 0 cf
 Routed to Reach BMP6 O : BMP-6 OVERFLOW
 Secondary = 0.04 cfs @ 12.87 hrs, Volume= 736 cf
 Routed to Pond 6A-PS : BB 6A - STONE

NO OVERFLOW

FLOW THROUGH
 BIORETENTION
 TREATMENT SECTION

Routing by Stor-Ind method, Time Span= 0.00-72.00 hrs, dt= 0.05 hrs
 Peak Elev= 10.72' @ 12.87 hrs Surf.Area= 576 sf Storage= 242 cf

Plug-Flow detention time= 60.3 min calculated for 736 cf (100% of inflow)
 Center-of-Mass det. time= 60.2 min (922.4 - 862.2)

Volume	Invert	Avail.Storage	Storage Description
#1	10.20'	491 cf	Custom Stage Data (Prismatic) Listed below (Recalc)

Elevation (feet)	Surf.Area (sq-ft)	Inc.Store (cubic-feet)	Cum.Store (cubic-feet)
10.20	350	0	0
11.10	740	491	491

Device	Routing	Invert	Outlet Devices
#1	Primary	9.00'	12.0" Round Culvert L= 10.0' CPP, square edge headwall, Ke= 0.500 Inlet / Outlet Invert= 9.00' / 8.90' S= 0.0100 '/ Cc= 0.900 n= 0.013, Flow Area= 0.79 sf
#2	Secondary	10.20'	2.410 in/hr Exfiltration over Surface area Conductivity to Groundwater Elevation = 7.00'
#3	Device 1	10.80'	24inch-Dome Grate Capacity
#4	Primary	11.00'	5.0' long Sharp-Crested Rectangular Weir 2 End Contraction(s)

Primary OutFlow Max=0.00 cfs @ 0.00 hrs HW=10.20' (Free Discharge)

- 1=Culvert (Passes 0.00 cfs of 2.86 cfs potential flow)
- 3=24inch-Dome Grate Capacity (Controls 0.00 cfs)
- 4=Sharp-Crested Rectangular Weir (Controls 0.00 cfs)

Secondary OutFlow Max=0.04 cfs @ 12.87 hrs HW=10.72' (Free Discharge)

- 2=Exfiltration (Controls 0.04 cfs)

Summary for Pond 6A-PS: BB 6A - STONE

Inflow = 0.04 cfs @ 12.87 hrs, Volume= 736 cf
 Outflow = 0.04 cfs @ 12.92 hrs, Volume= 714 cf, Atten= 0%, Lag= 2.8 min
 Primary = 0.04 cfs @ 12.92 hrs, Volume= 714 cf
 Routed to Reach BMP6_O : BMP-6 OVERFLOW

Routing by Stor-Ind method, Time Span= 0.00-72.00 hrs, dt= 0.05 hrs
 Peak Elev= 7.38' @ 12.92 hrs Surf.Area= 290 sf Storage= 33 cf

Plug-Flow detention time= 29.3 min calculated for 714 cf (97% of inflow)
 Center-of-Mass det. time= 14.0 min (936.4 - 922.4)

Volume	Invert	Avail.Storage	Storage Description
#1	7.00'	174 cf	Custom Stage Data (Prismatic) Listed below (Recalc) 580 cf Overall x 30.0% Voids

Elevation (feet)	Surf.Area (sq-ft)	Inc.Store (cubic-feet)	Cum.Store (cubic-feet)
7.00	290	0	0
9.00	290	580	580

Device	Routing	Invert	Outlet Devices
#1	Primary	7.25'	4.0" Vert. Orifice/Grate C= 0.600 Limited to weir flow at low heads

Primary OutFlow Max=0.04 cfs @ 12.92 hrs HW=7.38' (Free Discharge)
 ↑1=Orifice/Grate (Orifice Controls 0.04 cfs @ 1.21 fps)

Summary for Pond 6B-P: BB 6B

Inflow Area = 6,495 sf, 77.45% Impervious, Inflow Depth = 1.04" for 1.7-in event
 Inflow = 0.20 cfs @ 12.13 hrs, Volume= 564 cf
 Outflow = 0.02 cfs @ 13.26 hrs, Volume= 564 cf, Atten= 92%, Lag= 68.0 min
 Discarded = 0.02 cfs @ 13.26 hrs, Volume= 564 cf
 Primary = 0.00 cfs @ 0.00 hrs, Volume= 0 cf
 Routed to Reach BMP6_O : BMP-6 OVERFLOW

INFILTRATION

NO OVERFLOW

Routing by Stor-Ind method, Time Span= 0.00-72.00 hrs, dt= 0.05 hrs
 Peak Elev= 11.90' @ 13.26 hrs Surf.Area= 579 sf Storage= 269 cf

Plug-Flow detention time= 194.1 min calculated for 564 cf (100% of inflow)
 Center-of-Mass det. time= 194.0 min (1,013.8 - 819.8)

Volume	Invert	Avail.Storage	Storage Description
#1	11.20'	394 cf	Custom Stage Data (Prismatic) Listed below (Recalc)
Elevation (feet)	Surf.Area (sq-ft)	Inc.Store (cubic-feet)	Cum.Store (cubic-feet)
11.20	185	0	0
12.10	690	394	394

Device	Routing	Invert	Outlet Devices
#1	Primary	10.10'	12.0" Round Culvert L= 10.0' CPP, square edge headwall, Ke= 0.500 Inlet / Outlet Invert= 10.10' / 10.00' S= 0.0100 '/' Cc= 0.900 n= 0.013, Flow Area= 0.79 sf
#2	Discarded	11.20'	1.020 in/hr Exfiltration over Surface area Conductivity to Groundwater Elevation = 8.10'
#3	Device 1	11.95'	24inch-Dome Grate Capacity

Discarded OutFlow Max=0.02 cfs @ 13.26 hrs HW=11.90' (Free Discharge)
 ↑2=Exfiltration (Controls 0.02 cfs)

Primary OutFlow Max=0.00 cfs @ 0.00 hrs HW=11.20' (Free Discharge)
 ↑1=Culvert (Passes 0.00 cfs of 2.58 cfs potential flow)
 ↑3=24inch-Dome Grate Capacity (Controls 0.00 cfs)

Summary for Pond 7A-P: BB 7A PONDING

Inflow Area = 3,165 sf, 87.74% Impervious, Inflow Depth = 1.20" for 1.7-in event
 Inflow = 0.11 cfs @ 12.13 hrs, Volume= 316 cf
 Outflow = 0.02 cfs @ 12.61 hrs, Volume= 316 cf, Atten= 84%, Lag= 28.7 min
 Primary = 0.00 cfs @ 0.00 hrs, Volume= 0 cf
 Routed to Reach 7R : PARKING LOT C to HUDSON
 Secondary = 0.02 cfs @ 12.61 hrs, Volume= 316 cf
 Routed to Pond 7A-S : BB 7A - STONE

NO UNTREATED OVERFLOW

FLOW THROUGH
 BIORETENTION
 TREATMENT SECTION

Routing by Stor-Ind method, Time Span= 0.00-72.00 hrs, dt= 0.05 hrs
 Peak Elev= 9.84' @ 12.61 hrs Surf.Area= 281 sf Storage= 108 cf

Plug-Flow detention time= 53.4 min calculated for 316 cf (100% of inflow)
 Center-of-Mass det. time= 53.4 min (858.7 - 805.4)

Volume	Invert	Avail.Storage	Storage Description
#1	9.30'	227 cf	Custom Stage Data (Prismatic) Listed below (Recalc)

Elevation (feet)	Surf.Area (sq-ft)	Inc.Store (cubic-feet)	Cum.Store (cubic-feet)
9.30	115	0	0
10.20	390	227	227

Device	Routing	Invert	Outlet Devices
#1	Primary	8.10'	12.0" Round Culvert L= 10.0' CPP, square edge headwall, Ke= 0.500 Inlet / Outlet Invert= 8.10' / 8.00' S= 0.0100 '/ Cc= 0.900 n= 0.013, Flow Area= 0.79 sf
#2	Secondary	9.30'	2.410 in/hr Exfiltration over Surface area Conductivity to Groundwater Elevation = 6.10'
#3	Device 1	9.90'	24inch-Dome Grate Capacity
#4	Primary	10.10'	5.0' long Sharp-Crested Rectangular Weir 2 End Contraction(s)

Primary OutFlow Max=0.00 cfs @ 0.00 hrs HW=9.30' (Free Discharge)

- 1=Culvert (Passes 0.00 cfs of 2.86 cfs potential flow)
- 3=24inch-Dome Grate Capacity (Controls 0.00 cfs)
- 4=Sharp-Crested Rectangular Weir (Controls 0.00 cfs)

Secondary OutFlow Max=0.02 cfs @ 12.61 hrs HW=9.84' (Free Discharge)

- 2=Exfiltration (Controls 0.02 cfs)

Summary for Pond 7A-S: BB 7A - STONE

Inflow = 0.02 cfs @ 12.61 hrs, Volume= 316 cf
 Outflow = 0.02 cfs @ 12.64 hrs, Volume= 316 cf, Atten= 0%, Lag= 2.0 min
 Primary = 0.02 cfs @ 12.64 hrs, Volume= 316 cf
 Routed to Reach 7R : PARKING LOT C to HUDSON

Routing by Stor-Ind method, Time Span= 0.00-72.00 hrs, dt= 0.05 hrs
 Peak Elev= 5.18' @ 12.64 hrs Surf.Area= 150 sf Storage= 4 cf

Plug-Flow detention time= 5.7 min calculated for 316 cf (100% of inflow)
 Center-of-Mass det. time= 5.7 min (864.5 - 858.7)

Volume	Invert	Avail.Storage	Storage Description
#1	5.10'	90 cf	Custom Stage Data (Prismatic) Listed below (Recalc) 300 cf Overall x 30.0% Voids

Elevation (feet)	Surf.Area (sq-ft)	Inc.Store (cubic-feet)	Cum.Store (cubic-feet)
5.10	150	0	0
7.10	150	300	300

Device	Routing	Invert	Outlet Devices
#1	Primary	5.10'	4.0" Vert. Orifice/Grate C= 0.600 Limited to weir flow at low heads

Primary OutFlow Max=0.02 cfs @ 12.64 hrs HW=5.18' (Free Discharge)
 ↑1=Orifice/Grate (Orifice Controls 0.02 cfs @ 0.99 fps)

Summary for Pond 7B-P: BB 7B PONDING

Inflow Area = 4,942 sf, 88.73% Impervious, Inflow Depth = 1.20" for 1.7-in event
 Inflow = 0.17 cfs @ 12.13 hrs, Volume= 494 cf
 Outflow = 0.03 cfs @ 12.61 hrs, Volume= 494 cf, Atten= 84%, Lag= 28.9 min
 Primary = 0.00 cfs @ 0.00 hrs, Volume= 0 cf
 Routed to Reach BMP7 O : BMP-7 OVERFLOW
 Secondary = 0.03 cfs @ 12.61 hrs, Volume= 494 cf
 Routed to Pond 7B-S : BB 7B - STONE

NO UNTREATED OVERFLOW

FLOW THROUGH
 BIORETENTION
 TREATMENT SECTION

Routing by Stor-Ind method, Time Span= 0.00-72.00 hrs, dt= 0.05 hrs
 Peak Elev= 10.47' @ 12.61 hrs Surf.Area= 434 sf Storage= 162 cf

Plug-Flow detention time= 48.4 min calculated for 493 cf (100% of inflow)
 Center-of-Mass det. time= 48.4 min (853.7 - 805.4)

Volume	Invert	Avail.Storage	Storage Description
#1	10.00'	324 cf	Custom Stage Data (Prismatic) Listed below (Recalc)

Elevation (feet)	Surf.Area (sq-ft)	Inc.Store (cubic-feet)	Cum.Store (cubic-feet)
10.00	250	0	0
10.80	560	324	324

Device	Routing	Invert	Outlet Devices
#1	Primary	8.90'	12.0" Round Culvert L= 10.0' CPP, square edge headwall, Ke= 0.500 Inlet / Outlet Invert= 8.90' / 8.80' S= 0.0100 '/ Cc= 0.900 n= 0.013, Flow Area= 0.79 sf
#2	Secondary	10.00'	2.410 in/hr Exfiltration over Surface area Conductivity to Groundwater Elevation = 6.90'
#3	Device 1	10.60'	24inch-Dome Grate Capacity

Primary OutFlow Max=0.00 cfs @ 0.00 hrs HW=10.00' (Free Discharge)

- ↑1=Culvert (Passes 0.00 cfs of 2.58 cfs potential flow)
- ↑3=24inch-Dome Grate Capacity (Controls 0.00 cfs)

Secondary OutFlow Max=0.03 cfs @ 12.61 hrs HW=10.47' (Free Discharge)

- ↑2=Exfiltration (Controls 0.03 cfs)

Summary for Pond 7B-S: BB 7B - STONE

Inflow = 0.03 cfs @ 12.61 hrs, Volume= 494 cf
 Outflow = 0.03 cfs @ 12.64 hrs, Volume= 483 cf, Atten= 0%, Lag= 1.9 min
 Primary = 0.03 cfs @ 12.64 hrs, Volume= 483 cf
 Routed to Reach BMP7_O : BMP-7 OVERFLOW

Routing by Stor-Ind method, Time Span= 0.00-72.00 hrs, dt= 0.05 hrs
 Peak Elev= 7.61' @ 12.64 hrs Surf.Area= 150 sf Storage= 16 cf

Plug-Flow detention time= 26.1 min calculated for 482 cf (98% of inflow)
 Center-of-Mass det. time= 13.5 min (867.2 - 853.7)

Volume	Invert	Avail.Storage	Storage Description
#1	7.25'	90 cf	Custom Stage Data (Prismatic) Listed below (Recalc) 300 cf Overall x 30.0% Voids

Elevation (feet)	Surf.Area (sq-ft)	Inc.Store (cubic-feet)	Cum.Store (cubic-feet)
7.25	150	0	0
9.25	150	300	300

Device	Routing	Invert	Outlet Devices
#1	Primary	7.50'	4.0" Vert. Orifice/Grate C= 0.600 Limited to weir flow at low heads

Primary OutFlow Max=0.03 cfs @ 12.64 hrs HW=7.61' (Free Discharge)
 ↑1=Orifice/Grate (Orifice Controls 0.03 cfs @ 1.11 fps)

Summary for Pond 8a-P: BB 8A PONDING

Inflow Area = 3,978 sf, 79.99% Impervious, Inflow Depth = 1.04" for 1.7-in event
 Inflow = 0.12 cfs @ 12.13 hrs, Volume= 346 cf
 Outflow = 0.03 cfs @ 12.49 hrs, Volume= 346 cf, Atten= 78%, Lag= 21.9 min
 Primary = 0.00 cfs @ 0.00 hrs, Volume= 0 cf
 Routed to Reach P ST : PORTLAND STREET DRAINAGE
 Secondary = 0.03 cfs @ 12.49 hrs, Volume= 346 cf
 Routed to Pond 8a-s : BB 8A - STONE

NO UNTREATED OVERFLOW
 FLOW THROUGH
 BIORETENTION
 TREATMENT SECTION

Routing by Stor-Ind method, Time Span= 0.00-72.00 hrs, dt= 0.05 hrs
 Peak Elev= 8.71' @ 12.49 hrs Surf.Area= 452 sf Storage= 87 cf

Plug-Flow detention time= 22.8 min calculated for 345 cf (100% of inflow)
 Center-of-Mass det. time= 22.8 min (842.6 - 819.8)

Volume	Invert	Avail.Storage	Storage Description
#1	8.50'	575 cf	Custom Stage Data (Prismatic) Listed below (Recalc)

Elevation (feet)	Surf.Area (sq-ft)	Inc.Store (cubic-feet)	Cum.Store (cubic-feet)
8.50	360	0	0
9.50	790	575	575

Device	Routing	Invert	Outlet Devices
#1	Primary	7.40'	12.0" Round Culvert L= 10.0' CPP, square edge headwall, Ke= 0.500 Inlet / Outlet Invert= 7.40' / 7.30' S= 0.0100 '/ Cc= 0.900 n= 0.013, Flow Area= 0.79 sf
#2	Secondary	8.50'	2.410 in/hr Exfiltration over Surface area Conductivity to Groundwater Elevation = 5.40'
#3	Device 1	9.00'	24inch-Dome Grate Capacity
#4	Primary	9.40'	5.0' long Sharp-Crested Rectangular Weir 2 End Contraction(s)

Primary OutFlow Max=0.00 cfs @ 0.00 hrs HW=8.50' (Free Discharge)

- 1=Culvert (Passes 0.00 cfs of 2.58 cfs potential flow)
- 3=24inch-Dome Grate Capacity (Controls 0.00 cfs)
- 4=Sharp-Crested Rectangular Weir (Controls 0.00 cfs)

Secondary OutFlow Max=0.03 cfs @ 12.49 hrs HW=8.71' (Free Discharge)

- 2=Exfiltration (Controls 0.03 cfs)

Summary for Pond 8a-s: BB 8A - STONE

Inflow = 0.03 cfs @ 12.49 hrs, Volume= 346 cf
 Outflow = 0.03 cfs @ 12.55 hrs, Volume= 328 cf, Atten= 0%, Lag= 3.5 min
 Primary = 0.03 cfs @ 12.55 hrs, Volume= 328 cf
 Routed to Reach P ST : PORTLAND STREET DRAINAGE

Routing by Stor-Ind method, Time Span= 0.00-72.00 hrs, dt= 0.05 hrs
 Peak Elev= 5.61' @ 12.55 hrs Surf.Area= 300 sf Storage= 28 cf

Plug-Flow detention time= 51.9 min calculated for 328 cf (95% of inflow)
 Center-of-Mass det. time= 23.5 min (866.1 - 842.6)

Volume	Invert	Avail.Storage	Storage Description
#1	5.30'	180 cf	Custom Stage Data (Prismatic) Listed below (Recalc) 600 cf Overall x 30.0% Voids

Elevation (feet)	Surf.Area (sq-ft)	Inc.Store (cubic-feet)	Cum.Store (cubic-feet)
5.30	300	0	0
7.30	300	600	600

Device	Routing	Invert	Outlet Devices
#1	Primary	5.50'	4.0" Vert. Orifice/Grate C= 0.600 Limited to weir flow at low heads

Primary OutFlow Max=0.03 cfs @ 12.55 hrs HW=5.61' (Free Discharge)
 ↑ **1=Orifice/Grate** (Orifice Controls 0.03 cfs @ 1.11 fps)

Summary for Pond 8B-P: BB 8B-PONDING

Inflow Area = 5,598 sf, 87.78% Impervious, Inflow Depth = 1.20" for 1.7-in event
 Inflow = 0.19 cfs @ 12.13 hrs, Volume= 559 cf
 Outflow = 0.03 cfs @ 12.58 hrs, Volume= 559 cf, Atten= 82%, Lag= 27.2 min

Primary = 0.00 cfs @ 0.00 hrs, Volume= 0 cf
 Routed to Reach 7R : PARKING LOT C to HUDSON

Secondary = 0.03 cfs @ 12.58 hrs, Volume= 559 cf
 Routed to Pond 8B-S : BB 8B-Stone

NO UNTREATED OVERFLOW

FLOW THROUGH
 BIORETENTION
 TREATMENT SECTION

Routing by Stor-Ind method, Time Span= 0.00-72.00 hrs, dt= 0.05 hrs
 Peak Elev= 9.60' @ 12.58 hrs Surf.Area= 547 sf Storage= 186 cf

Plug-Flow detention time= 48.0 min calculated for 559 cf (100% of inflow)
 Center-of-Mass det. time= 48.0 min (853.4 - 805.4)

Volume	Invert	Avail.Storage	Storage Description
#1	9.10'	306 cf	Custom Stage Data (Prismatic) Listed below (Recalc)

Elevation (feet)	Surf.Area (sq-ft)	Inc.Store (cubic-feet)	Cum.Store (cubic-feet)
9.10	190	0	0
9.80	685	306	306

Device	Routing	Invert	Outlet Devices
#1	Primary	7.90'	12.0" Round Culvert L= 10.0' CPP, square edge headwall, Ke= 0.500 Inlet / Outlet Invert= 7.90' / 7.80' S= 0.0100 '/ Cc= 0.900 n= 0.013, Flow Area= 0.79 sf
#2	Secondary	9.10'	2.410 in/hr Exfiltration over Surface area Conductivity to Groundwater Elevation = 5.90'
#3	Device 1	9.65'	24inch-Dome Grate Capacity X 2.00

Primary OutFlow Max=0.00 cfs @ 0.00 hrs HW=9.10' (Free Discharge)

- ↑1=Culvert (Passes 0.00 cfs of 2.86 cfs potential flow)
- ↑3=24inch-Dome Grate Capacity (Controls 0.00 cfs)

Secondary OutFlow Max=0.03 cfs @ 12.58 hrs HW=9.60' (Free Discharge)

- ↑2=Exfiltration (Controls 0.03 cfs)

Summary for Pond 8B-S: BB 8B-Stone

Inflow = 0.03 cfs @ 12.58 hrs, Volume= 559 cf
 Outflow = 0.03 cfs @ 12.63 hrs, Volume= 532 cf, Atten= 0%, Lag= 2.8 min
 Primary = 0.03 cfs @ 12.63 hrs, Volume= 532 cf
 Routed to Reach 7R : PARKING LOT C to HUDSON

Routing by Stor-Ind method, Time Span= 0.00-72.00 hrs, dt= 0.05 hrs
 Peak Elev= 6.32' @ 12.63 hrs Surf.Area= 300 sf Storage= 38 cf

Plug-Flow detention time= 50.0 min calculated for 532 cf (95% of inflow)
 Center-of-Mass det. time= 24.8 min (878.2 - 853.4)

Volume	Invert	Avail.Storage	Storage Description
#1	5.90'	180 cf	Custom Stage Data (Prismatic) Listed below (Recalc) 600 cf Overall x 30.0% Voids

Elevation (feet)	Surf.Area (sq-ft)	Inc.Store (cubic-feet)	Cum.Store (cubic-feet)
5.90	300	0	0
7.90	300	600	600

Device	Routing	Invert	Outlet Devices
#1	Primary	6.20'	4.0" Vert. Orifice/Grate C= 0.600 Limited to weir flow at low heads

Primary OutFlow Max=0.03 cfs @ 12.63 hrs HW=6.32' (Free Discharge)
 ↑**1=Orifice/Grate** (Orifice Controls 0.03 cfs @ 1.18 fps)

Summary for Pond 9-P: BB9 - POND

Inflow Area = 29,651 sf, 74.77% Impervious, Inflow Depth = 0.97" for 1.7-in event
 Inflow = 0.84 cfs @ 12.13 hrs, Volume= 2,402 cf
 Outflow = 0.81 cfs @ 12.15 hrs, Volume= 2,402 cf, Atten= 4%, Lag= 1.2 min

Primary = 0.00 cfs @ 0.00 hrs, Volume= 0 cf
 Routed to Reach BMP9 O : BMP-9 OVERFLOW

Secondary = 0.04 cfs @ 12.15 hrs, Volume= 1,207 cf
 Routed to Pond 9-PS : BB9 - STONE

Tertiary = 0.77 cfs @ 12.15 hrs, Volume= 1,195 cf
 Routed to Reach 1R : ISOLATOR ROW C

NO UNTREATED OVERFLOW

FLOW THROUGH
 BIORETENTION
 TREATMENT SECTION

REMAINING FLOW TO
 ISOLATOR ROW

Routing by Stor-Ind method, Time Span= 0.00-72.00 hrs, dt= 0.05 hrs
 Peak Elev= 8.66' @ 12.15 hrs Surf.Area= 579 sf Storage= 253 cf

Plug-Flow detention time= 34.9 min calculated for 2,400 cf (100% of inflow)
 Center-of-Mass det. time= 34.9 min (860.9 - 826.0)

Volume	Invert	Avail.Storage	Storage Description
#1	8.00'	485 cf	Custom Stage Data (Prismatic) Listed below (Recalc)

Elevation (feet)	Surf.Area (sq-ft)	Inc.Store (cubic-feet)	Cum.Store (cubic-feet)
8.00	190	0	0
9.00	780	485	485

Device	Routing	Invert	Outlet Devices
#1	Primary	7.00'	12.0" Round Culvert L= 10.0' CPP, square edge headwall, Ke= 0.500 Inlet / Outlet Invert= 7.00' / 6.90' S= 0.0100 '/' Cc= 0.900 n= 0.013, Flow Area= 0.79 sf
#2	Secondary	8.00'	2.410 in/hr Exfiltration over Surface area Conductivity to Groundwater Elevation = 5.00'
#3	Device 1	8.80'	24inchDome Grate Capacity Head (feet) 0.00 0.05 0.10 0.15 0.20 0.25 0.30 0.35 0.40 0.45 0.50 0.55 0.60 0.65 0.70 0.75 0.80 0.85 0.90 0.95 1.00 1.05 1.10 Disch. (cfs) 0.000 0.180 0.460 0.850 1.360 1.830 2.420 3.100 3.600 3.800 4.000 4.200 4.380 4.600 4.750 4.900 5.100 5.200 5.350 5.450 5.650 5.800 5.950
#4	Tertiary	8.50'	15inch-Dome Grate Capacity

Primary OutFlow Max=0.00 cfs @ 0.00 hrs HW=8.00' (Free Discharge)
 ↑1=Culvert (Passes 0.00 cfs of 2.27 cfs potential flow)
 ↑3=24inchDome Grate Capacity (Controls 0.00 cfs)

Secondary OutFlow Max=0.04 cfs @ 12.15 hrs HW=8.66' (Free Discharge)
 ↑2=Exfiltration (Controls 0.04 cfs)

Tertiary OutFlow Max=0.77 cfs @ 12.15 hrs HW=8.66' (Free Discharge)
 ↑4=15inch-Dome Grate Capacity (Custom Controls 0.77 cfs)

Summary for Pond 9-PS: BB9 - STONE

Inflow = 0.04 cfs @ 12.15 hrs, Volume= 1,207 cf
 Outflow = 0.04 cfs @ 12.18 hrs, Volume= 1,193 cf, Atten= 1%, Lag= 1.8 min
 Primary = 0.04 cfs @ 12.18 hrs, Volume= 1,193 cf
 Routed to Reach BMP9_O : BMP-9 OVERFLOW

Routing by Stor-Ind method, Time Span= 0.00-72.00 hrs, dt= 0.05 hrs
 Peak Elev= 5.38' @ 12.18 hrs Surf.Area= 190 sf Storage= 21 cf

Plug-Flow detention time= 16.2 min calculated for 1,193 cf (99% of inflow)
 Center-of-Mass det. time= 9.6 min (986.1 - 976.5)

Volume	Invert	Avail.Storage	Storage Description
#1	5.00'	114 cf	Custom Stage Data (Prismatic) Listed below (Recalc) 380 cf Overall x 30.0% Voids

Elevation (feet)	Surf.Area (sq-ft)	Inc.Store (cubic-feet)	Cum.Store (cubic-feet)
5.00	190	0	0
7.00	190	380	380

Device	Routing	Invert	Outlet Devices
#1	Primary	5.25'	4.0" Vert. Orifice/Grate C= 0.600 Limited to weir flow at low heads

Primary OutFlow Max=0.04 cfs @ 12.18 hrs HW=5.38' (Free Discharge)
 ↑1=Orifice/Grate (Orifice Controls 0.04 cfs @ 1.21 fps)

Summary for Pond 14P: BB2A-Stone

Inflow = 0.02 cfs @ 12.60 hrs, Volume= 334 cf
 Outflow = 0.02 cfs @ 12.64 hrs, Volume= 334 cf, Atten= 0%, Lag= 2.3 min
 Primary = 0.02 cfs @ 12.64 hrs, Volume= 334 cf
 Routed to Reach DP-1 : French Rodney Blvd Outfall

Routing by Stor-Ind method, Time Span= 0.00-72.00 hrs, dt= 0.05 hrs
 Peak Elev= 5.59' @ 12.64 hrs Surf.Area= 180 sf Storage= 5 cf

Plug-Flow detention time= 6.8 min calculated for 334 cf (100% of inflow)
 Center-of-Mass det. time= 6.8 min (849.4 - 842.6)

Volume	Invert	Avail.Storage	Storage Description
#1	5.50'	108 cf	Custom Stage Data (Prismatic) Listed below (Recalc) 360 cf Overall x 30.0% Voids

Elevation (feet)	Surf.Area (sq-ft)	Inc.Store (cubic-feet)	Cum.Store (cubic-feet)
5.50	180	0	0
7.50	180	360	360

Device	Routing	Invert	Outlet Devices
#1	Primary	5.50'	4.0" Vert. Orifice/Grate C= 0.600 Limited to weir flow at low heads

Primary OutFlow Max=0.02 cfs @ 12.64 hrs HW=5.59' (Free Discharge)
 ↑1=Orifice/Grate (Orifice Controls 0.02 cfs @ 1.00 fps)

Summary for Pond DMH1: DIVERSION MANHOLE - SEYMOUR ST

[57] Hint: Peaked at 9.36' (Flood elevation advised)

Inflow Area = 19,582 sf, 58.17% Impervious, Inflow Depth = 0.73" for 1.7-in event
 Inflow = 0.42 cfs @ 12.13 hrs, Volume= 1,191 cf
 Outflow = 0.42 cfs @ 12.13 hrs, Volume= 1,191 cf, Atten= 0%, Lag= 0.0 min
 Primary = 0.31 cfs @ 12.13 hrs, Volume= 1,130 cf
 Routed to Pond INF-1 : INFILTRATION SYSTEM #1
 Secondary = 0.11 cfs @ 12.13 hrs, Volume= 61 cf
 Routed to Reach DP-1 : French Rodney Blvd Outfall

Routing by Stor-Ind method, Time Span= 0.00-72.00 hrs, dt= 0.05 hrs
 Peak Elev= 9.36' @ 12.13 hrs

Device	Routing	Invert	Outlet Devices
#1	Primary	9.00'	6.0" Vert. WATER QUALITY STORM DIVERSION C= 0.600 Limited to weir flow at low heads
#2	Secondary	9.20'	12.0" Vert. LARGE STORM OVEFLOW C= 0.600 Limited to weir flow at low heads

Primary OutFlow Max=0.30 cfs @ 12.13 hrs HW=9.35' (Free Discharge)
 ↖1=**WATER QUALITY STORM DIVERSION**(Orifice Controls 0.30 cfs @ 2.02 fps)

Secondary OutFlow Max=0.10 cfs @ 12.13 hrs HW=9.35' (Free Discharge)
 ↖2=**LARGE STORM OVEFLOW**(Orifice Controls 0.10 cfs @ 1.34 fps)

Summary for Pond DMH2: DIVERSION MANHOLE - HUDSON STREET

[57] Hint: Peaked at 11.81' (Flood elevation advised)

Inflow Area = 143,309 sf, 49.69% Impervious, Inflow Depth = 0.63" for 1.7-in event
 Inflow = 2.62 cfs @ 12.14 hrs, Volume= 7,514 cf
 Outflow = 2.62 cfs @ 12.14 hrs, Volume= 7,514 cf, Atten= 0%, Lag= 0.0 min
 Primary = 0.93 cfs @ 12.14 hrs, Volume= 6,224 cf
 Routed to Pond INF-2 : INFILTRATION SYSTEM #2
 Secondary = 1.70 cfs @ 12.14 hrs, Volume= 1,290 cf
 Routed to Reach B : PARKING LOT B OVERFLOW

Routing by Stor-Ind method, Time Span= 0.00-72.00 hrs, dt= 0.05 hrs
 Peak Elev= 11.81' @ 12.14 hrs

Device	Routing	Invert	Outlet Devices
#1	Primary	10.60'	6.0" Vert. WATER QUALITY STORM DIVERSION C= 0.600 Limited to weir flow at low heads
#2	Secondary	11.10'	12.0" Vert. LARGE STORM OVERFLOW C= 0.600 Limited to weir flow at low heads

Primary OutFlow Max=0.91 cfs @ 12.14 hrs HW=11.78' (Free Discharge)
 ↖1=**WATER QUALITY STORM DIVERSION**(Orifice Controls 0.91 cfs @ 4.65 fps)

Secondary OutFlow Max=1.61 cfs @ 12.14 hrs HW=11.78' (Free Discharge)
 ↖2=**LARGE STORM OVERFLOW**(Orifice Controls 1.61 cfs @ 2.82 fps)

Summary for Pond DMH3: DIVERSION MANHOLE - PORTLAND ST

[57] Hint: Peaked at 11.31' (Flood elevation advised)

Inflow Area = 19,743 sf, 50.83% Impervious, Inflow Depth = 0.63" for 1.7-in event
 Inflow = 0.36 cfs @ 12.14 hrs, Volume= 1,035 cf
 Outflow = 0.36 cfs @ 12.14 hrs, Volume= 1,035 cf, Atten= 0%, Lag= 0.0 min
 Primary = 0.31 cfs @ 12.14 hrs, Volume= 1,012 cf
 Routed to Pond INF3 : INFILTRATION SYSTEM #1
 Secondary = 0.05 cfs @ 12.14 hrs, Volume= 23 cf
 Routed to Reach P ST : PORTLAND STREET DRAINAGE

Routing by Stor-Ind method, Time Span= 0.00-72.00 hrs, dt= 0.05 hrs
 Peak Elev= 11.31' @ 12.14 hrs

Device	Routing	Invert	Outlet Devices
#1	Primary	11.00'	8.0" Vert. WATER QUALITY DIVERSION C= 0.600 Limited to weir flow at low heads
#2	Secondary	11.20'	10.0" Vert. LARGE STORM OVERFLOW C= 0.600 Limited to weir flow at low heads

Primary OutFlow Max=0.30 cfs @ 12.14 hrs HW=11.31' (Free Discharge)
 ↳1=**WATER QUALITY DIVERSION**(Orifice Controls 0.30 cfs @ 1.89 fps)

Secondary OutFlow Max=0.05 cfs @ 12.14 hrs HW=11.31' (Free Discharge)
 ↳2=**LARGE STORM OVERFLOW**(Orifice Controls 0.05 cfs @ 1.13 fps)

Summary for Pond INF-1: INFILTRATION SYSTEM #1

Inflow Area = 19,582 sf, 58.17% Impervious, Inflow Depth = 0.69" for 1.7-in event
 Inflow = 0.31 cfs @ 12.13 hrs, Volume= 1,130 cf
 Outflow = 0.05 cfs @ 12.92 hrs, Volume= 1,130 cf, Atten= 83%, Lag= 46.9 min
 Discarded = 0.05 cfs @ 12.92 hrs, Volume= 1,130 cf
 Primary = 0.00 cfs @ 0.00 hrs, Volume= 0 cf
 Routed to Reach DP-1 : French Rodney Blvd Outfall

INFILTRATION

NO OVERFLOW

Routing by Stor-Ind method, Time Span= 0.00-72.00 hrs, dt= 0.05 hrs
 Peak Elev= 8.33' @ 12.92 hrs Surf.Area= 1,772 sf Storage= 364 cf

Plug-Flow detention time= 60.0 min calculated for 1,130 cf (100% of inflow)
 Center-of-Mass det. time= 59.9 min (913.9 - 854.0)

Volume	Invert	Avail.Storage	Storage Description
#1A	7.80'	1,091 cf	21.50'W x 81.52'L x 2.33'H Field A 4,090 cf Overall - 973 cf Embedded = 3,117 cf x 35.0% Voids
#2A	8.30'	973 cf	ADS_StormTech SC-310 +Cap x 66 Inside #1 Effective Size= 28.9"W x 16.0"H => 2.07 sf x 7.12'L = 14.7 cf Overall Size= 34.0"W x 16.0"H x 7.56'L with 0.44' Overlap 66 Chambers in 6 Rows
#3	7.80'	137 cf	5.00'D x 7.00'H Vertical Cone/Cylinder
		2,201 cf	Total Available Storage

Storage Group A created with Chamber Wizard

Device	Routing	Invert	Outlet Devices
#1	Discarded	7.80'	1.020 in/hr Exfiltration over Surface area Conductivity to Groundwater Elevation = 5.80'
#2	Primary	8.10'	10.0" Round Culvert L= 10.0' CPP, square edge headwall, Ke= 0.500 Inlet / Outlet Invert= 8.10' / 8.00' S= 0.0100 '/' Cc= 0.900 n= 0.012 Corrugated PP, smooth interior, Flow Area= 0.55 sf
#3	Device 2	9.40'	5.0' long Sharp-Crested Rectangular Weir 2 End Contraction(s)

Discarded OutFlow Max=0.05 cfs @ 12.92 hrs HW=8.33' (Free Discharge)
 ↑1=Exfiltration (Controls 0.05 cfs)

Primary OutFlow Max=0.00 cfs @ 0.00 hrs HW=7.80' (Free Discharge)
 ↑2=Culvert (Controls 0.00 cfs)
 ↑3=Sharp-Crested Rectangular Weir(Controls 0.00 cfs)

Summary for Pond INF-2: INFILTRATION SYSTEM #2

Inflow Area = 143,309 sf, 49.69% Impervious, Inflow Depth = 0.52" for 1.7-in event
 Inflow = 0.93 cfs @ 12.14 hrs, Volume= 6,224 cf
 Outflow = 0.11 cfs @ 15.09 hrs, Volume= 6,224 cf, Atten= 89%, Lag= 177.2 min
 Discarded = 0.11 cfs @ 15.09 hrs, Volume= 6,224 cf
 Primary = 0.00 cfs @ 0.00 hrs, Volume= 0 cf
 Routed to Reach B : PARKING LOT B OVERFLOW

INFILTRATION

NO OVERFLOW

Routing by Stor-Ind method, Time Span= 0.00-72.00 hrs, dt= 0.05 hrs
 Peak Elev= 9.46' @ 15.09 hrs Surf.Area= 2,268 sf Storage= 2,921 cf

Plug-Flow detention time= 338.9 min calculated for 6,220 cf (100% of inflow)
 Center-of-Mass det. time= 339.0 min (1,222.8 - 883.8)

Volume	Invert	Avail.Storage	Storage Description
#1A	7.50'	1,790 cf	25.25'W x 89.06'L x 3.50'H Field A 7,870 cf Overall - 2,756 cf Embedded = 5,114 cf x 35.0% Voids
#2A	8.00'	2,756 cf	ADS_StormTech SC-740 +Cap x 60 Inside #1 Effective Size= 44.6"W x 30.0"H => 6.45 sf x 7.12'L = 45.9 cf Overall Size= 51.0"W x 30.0"H x 7.56'L with 0.44' Overlap 60 Chambers in 5 Rows
#3	7.50'	137 cf	5.00'D x 7.00'H Vertical Cone/Cylinder
		4,684 cf	Total Available Storage

Storage Group A created with Chamber Wizard

Device	Routing	Invert	Outlet Devices
#1	Discarded	7.50'	1.020 in/hr Exfiltration over Surface area Conductivity to Groundwater Elevation = 5.50'
#2	Primary	8.00'	10.0" Round Culvert L= 10.0' CPP, square edge headwall, Ke= 0.500 Inlet / Outlet Invert= 8.00' / 7.90' S= 0.0100 '/' Cc= 0.900 n= 0.012 Corrugated PP, smooth interior, Flow Area= 0.55 sf
#3	Device 2	9.50'	5.0' long Sharp-Crested Rectangular Weir 2 End Contraction(s)

Discarded OutFlow Max=0.11 cfs @ 15.09 hrs HW=9.46' (Free Discharge)
 ↑1=Exfiltration (Controls 0.11 cfs)

Primary OutFlow Max=0.00 cfs @ 0.00 hrs HW=7.50' (Free Discharge)
 ↑2=Culvert (Controls 0.00 cfs)
 ↑3=Sharp-Crested Rectangular Weir(Controls 0.00 cfs)

Summary for Pond INF3: INFILTRATION SYSTEM #1

Inflow Area = 19,743 sf, 50.83% Impervious, Inflow Depth = 0.62" for 1.7-in event
 Inflow = 0.31 cfs @ 12.14 hrs, Volume= 1,012 cf
 Outflow = 0.04 cfs @ 13.22 hrs, Volume= 1,012 cf, Atten= 88%, Lag= 64.8 min
 Discarded = 0.04 cfs @ 13.22 hrs, Volume= 1,012 cf
 Primary = 0.00 cfs @ 0.00 hrs, Volume= 0 cf
 Routed to Reach P ST : PORTLAND STREET DRAINAGE

INFILTRATION

NO OVERFLOW

Routing by Stor-Ind method, Time Span= 0.00-72.00 hrs, dt= 0.05 hrs
 Peak Elev= 8.82' @ 13.22 hrs Surf.Area= 1,113 sf Storage= 385 cf

Plug-Flow detention time= 100.5 min calculated for 1,011 cf (100% of inflow)
 Center-of-Mass det. time= 100.5 min (960.8 - 860.3)

Volume	Invert	Avail.Storage	Storage Description
#1A	8.10'	686 cf	18.17'W x 60.16'L x 2.33'H Field A 2,550 cf Overall - 590 cf Embedded = 1,960 cf x 35.0% Voids
#2A	8.60'	590 cf	ADS_StormTech SC-310 +Cap x 40 Inside #1 Effective Size= 28.9"W x 16.0"H => 2.07 sf x 7.12'L = 14.7 cf Overall Size= 34.0"W x 16.0"H x 7.56'L with 0.44' Overlap 40 Chambers in 5 Rows
#3	8.10'	137 cf	5.00'D x 7.00'H Vertical Cone/Cylinder
		1,413 cf	Total Available Storage

Storage Group A created with Chamber Wizard

Device	Routing	Invert	Outlet Devices
#1	Discarded	8.10'	1.020 in/hr Exfiltration over Surface area Conductivity to Groundwater Elevation = 6.10'
#2	Primary	8.40'	10.0" Round Culvert L= 10.0' CPP, square edge headwall, Ke= 0.500 Inlet / Outlet Invert= 8.40' / 8.30' S= 0.0100 '/ Cc= 0.900 n= 0.012 Corrugated PP, smooth interior, Flow Area= 0.55 sf
#3	Device 2	9.50'	5.0' long Sharp-Crested Rectangular Weir 2 End Contraction(s)

Discarded OutFlow Max=0.04 cfs @ 13.22 hrs HW=8.82' (Free Discharge)
 ↑1=Exfiltration (Controls 0.04 cfs)

Primary OutFlow Max=0.00 cfs @ 0.00 hrs HW=8.10' (Free Discharge)
 ↑2=Culvert (Controls 0.00 cfs)
 ↑3=Sharp-Crested Rectangular Weir(Controls 0.00 cfs)

APPENDIX C

Pre-Development Conditions – HydroCAD Calculations

EXISTING HYDROCAD ANALYSIS

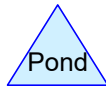
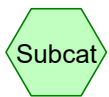
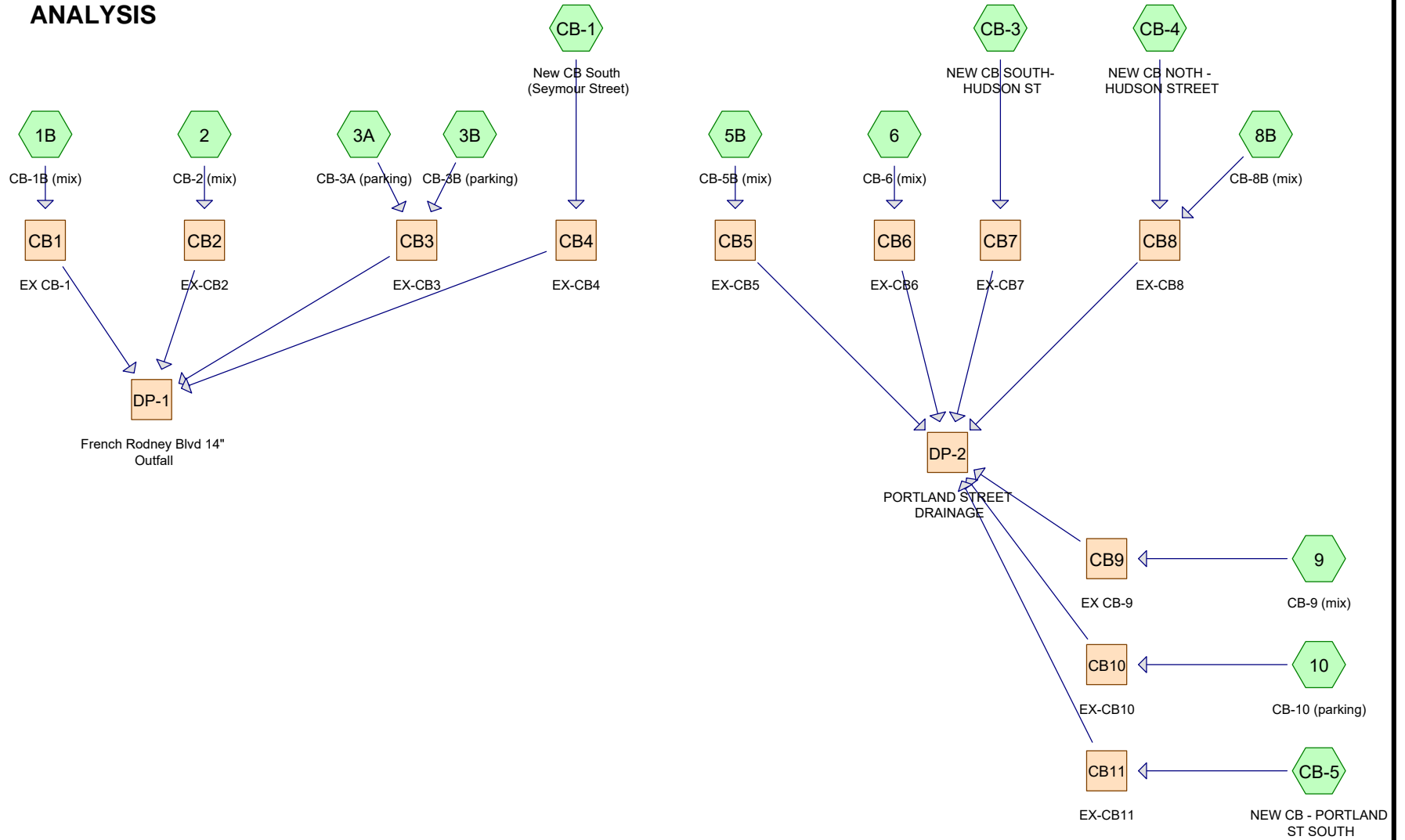

Routing Diagram for 14850_Existing-Drainage-Areas
 Prepared by {enter your company name here}, Printed 4/6/2022
 HydroCAD® 10.10-7a s/n 00546 © 2021 HydroCAD Software Solutions LLC

14850_Existing-Drainage-Areas

Prepared by {enter your company name here}

HydroCAD® 10.10-7a s/n 00546 © 2021 HydroCAD Software Solutions LLC

Printed 4/6/2022

Page 2

Rainfall Events Listing (selected events)

Event#	Event Name	Storm Type	Curve	Mode	Duration (hours)	B/B	Depth (inches)	AMC
1	NOAA 10-yr	NOAA 24-hr	C	Default	24.00	1	5.02	2
2	NOAA 100-yr	NOAA 24-hr	C	Default	24.00	1	7.59	2
3	NOAA 2-yr	NOAA 24-hr	C	Default	24.00	1	3.40	2
4	NOAA 25-yr	NOAA 24-hr	C	Default	24.00	1	6.04	2

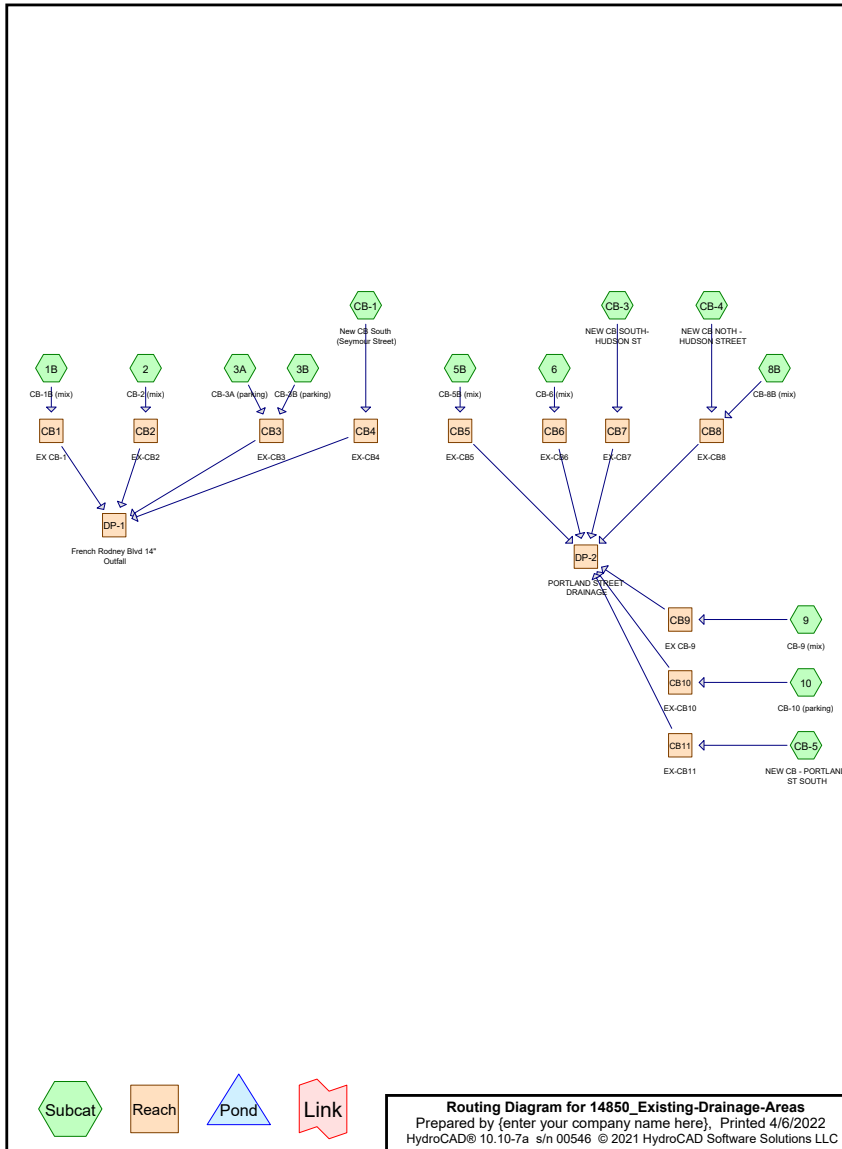

14850_Existing-Drainage-Areas

Prepared by {enter your company name here}

HydroCAD® 10.10-7a s/n 00546 © 2021 HydroCAD Software Solutions LLC

Printed 4/6/2022

Page 3

Area Listing (all nodes)

Area (acres)	CN	Description (subcatchment-numbers)
5.059	83	1/4 acre lots, 38% imp, HSG C (1B, 2, 5B, 6, 8B, 9, CB-1, CB-3, CB-4, CB-5)
2.771	98	Paved parking, HSG C (1B, 2, 3A, 3B, 5B, 6, 8B, 9, 10)
0.861	98	Roadway (CB-1, CB-3, CB-4, CB-5)
8.690	89	TOTAL AREA

14850_Existing-Drainage-Areas

NOAA 24-hr C NOAA 10-yr Rainfall=5.02"

Prepared by {enter your company name here}

HydroCAD® 10.10-7a s/n 00546 © 2021 HydroCAD Software Solutions LLC

Printed 4/6/2022

Page 4

Time span=0.00-72.00 hrs, dt=0.05 hrs, 1441 points
 Runoff by SCS TR-20 method, UH=SCS, Weighted-CN
 Reach routing by Stor-Ind+Trans method - Pond routing by Stor-Ind method

Subcatchment1B: CB-1B (mix)	Runoff Area=33,097 sf 61.34% Impervious Runoff Depth=3.79" Tc=6.0 min CN=89 Runoff=3.50 cfs 0.240 af
Subcatchment2: CB-2 (mix)	Runoff Area=22,628 sf 71.14% Impervious Runoff Depth=4.00" Tc=6.0 min CN=91 Runoff=2.48 cfs 0.173 af
Subcatchment3A: CB-3A (parking)	Runoff Area=7,758 sf 100.00% Impervious Runoff Depth=4.78" Tc=6.0 min CN=98 Runoff=0.92 cfs 0.071 af
Subcatchment3B: CB-3B (parking)	Runoff Area=3,797 sf 100.00% Impervious Runoff Depth=4.78" Tc=6.0 min CN=98 Runoff=0.45 cfs 0.035 af
Subcatchment5B: CB-5B (mix)	Runoff Area=22,974 sf 57.51% Impervious Runoff Depth=3.69" Tc=6.0 min CN=88 Runoff=2.38 cfs 0.162 af
Subcatchment6: CB-6 (mix)	Runoff Area=34,524 sf 93.00% Impervious Runoff Depth=4.55" Tc=6.0 min CN=96 Runoff=4.05 cfs 0.301 af
Subcatchment8B: CB-8B (mix)	Runoff Area=28,528 sf 54.52% Impervious Runoff Depth=3.59" Tc=6.0 min CN=87 Runoff=2.89 cfs 0.196 af
Subcatchment9: CB-9 (mix)	Runoff Area=36,104 sf 94.03% Impervious Runoff Depth=4.67" Tc=6.0 min CN=97 Runoff=4.27 cfs 0.322 af
Subcatchment10: CB-10 (parking)	Runoff Area=6,492 sf 100.00% Impervious Runoff Depth=4.78" Tc=6.0 min CN=98 Runoff=0.77 cfs 0.059 af
SubcatchmentCB-1: New CB South	Runoff Area=19,582 sf 58.17% Impervious Runoff Depth=3.69" Flow Length=512' Tc=6.0 min CN=88 Runoff=2.03 cfs 0.138 af
SubcatchmentCB-3: NEW CB SOUTH-	Runoff Area=25,183 sf 51.84% Impervious Runoff Depth=3.49" Flow Length=635' Tc=6.0 min CN=86 Runoff=2.49 cfs 0.168 af
SubcatchmentCB-4: NEW CB NOTH -	Runoff Area=118,126 sf 49.24% Impervious Runoff Depth=3.49" Flow Length=822' Tc=6.0 min CN=86 Runoff=11.70 cfs 0.788 af
SubcatchmentCB-5: NEW CB -	Runoff Area=19,743 sf 50.83% Impervious Runoff Depth=3.49" Flow Length=574' Tc=6.0 min CN=86 Runoff=1.96 cfs 0.132 af
Reach CB1: EX CB-1	Inflow=3.50 cfs 0.240 af Outflow=3.50 cfs 0.240 af
Reach CB10: EX-CB10	Inflow=0.77 cfs 0.059 af Outflow=0.77 cfs 0.059 af
Reach CB11: EX-CB11	Inflow=1.96 cfs 0.132 af Outflow=1.96 cfs 0.132 af

14850_Existing-Drainage-Areas

NOAA 24-hr C NOAA 10-yr Rainfall=5.02"

Prepared by {enter your company name here}

Printed 4/6/2022

HydroCAD® 10.10-7a s/n 00546 © 2021 HydroCAD Software Solutions LLC

Page 5

Reach CB2: EX-CB2	Inflow=2.48 cfs 0.173 af Outflow=2.48 cfs 0.173 af
Reach CB3: EX-CB3	Inflow=1.37 cfs 0.106 af Outflow=1.37 cfs 0.106 af
Reach CB4: EX-CB4	Inflow=2.03 cfs 0.138 af Outflow=2.03 cfs 0.138 af
Reach CB5: EX-CB5	Inflow=2.38 cfs 0.162 af Outflow=2.38 cfs 0.162 af
Reach CB6: EX-CB6	Inflow=4.05 cfs 0.301 af Outflow=4.05 cfs 0.301 af
Reach CB7: EX-CB7	Inflow=2.49 cfs 0.168 af Outflow=2.49 cfs 0.168 af
Reach CB8: EX-CB8	Inflow=14.59 cfs 0.983 af Outflow=14.59 cfs 0.983 af
Reach CB9: EX CB-9	Inflow=4.27 cfs 0.322 af Outflow=4.27 cfs 0.322 af
Reach DP-1: French Rodney Blvd 14" Outfall	Inflow=9.38 cfs 0.657 af Outflow=9.38 cfs 0.657 af
Reach DP-2: PORTLANDSTREET DRAINAGE	Inflow=30.51 cfs 2.128 af Outflow=30.51 cfs 2.128 af

Total Runoff Area = 8.690 ac Runoff Volume = 2.785 af Average Runoff Depth = 3.85"
36.09% Pervious = 3.136 ac 63.91% Impervious = 5.554 ac

14850_Existing-Drainage-Areas

NOAA 24-hr C NOAA 10-yr Rainfall=5.02"

Prepared by {enter your company name here}

Printed 4/6/2022

HydroCAD® 10.10-7a s/n 00546 © 2021 HydroCAD Software Solutions LLC

Page 6

Summary for Subcatchment 1B: CB-1B (mix)

Runoff = 3.50 cfs @ 12.13 hrs, Volume= 0.240 af, Depth= 3.79"
Routed to Reach CB1 : EX CB-1

Runoff by SCS TR-20 method, UH=SCS, Weighted-CN, Time Span= 0.00-72.00 hrs, dt= 0.05 hrs
NOAA 24-hr C NOAA 10-yr Rainfall=5.02"

Area (sf)	CN	Description
20,636	83	1/4 acre lots, 38% imp, HSG C
12,461	98	Paved parking, HSG C
33,097	89	Weighted Average
12,794		38.66% Pervious Area
20,303		61.34% Impervious Area

Tc (min)	Length (feet)	Slope (ft/ft)	Velocity (ft/sec)	Capacity (cfs)	Description
6.0					Direct Entry, residential & parking areas

Subcatchment 1B: CB-1B (mix)

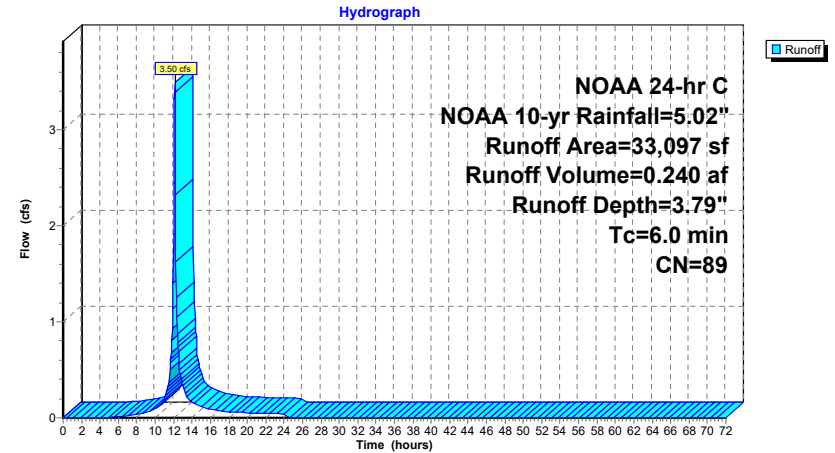

14850_Existing-Drainage-Areas

NOAA 24-hr C NOAA 10-yr Rainfall=5.02"

Prepared by {enter your company name here}

Printed 4/6/2022

HydroCAD® 10.10-7a s/n 00546 © 2021 HydroCAD Software Solutions LLC

Page 7

Summary for Subcatchment 2: CB-2 (mix)

Runoff = 2.48 cfs @ 12.13 hrs, Volume= 0.173 af, Depth= 4.00"
Routed to Reach CB2 : EX-CB2

Runoff by SCS TR-20 method, UH=SCS, Weighted-CN, Time Span= 0.00-72.00 hrs, dt= 0.05 hrs
NOAA 24-hr C NOAA 10-yr Rainfall=5.02"

Area (sf)	CN	Description
10,533	83	1/4 acre lots, 38% imp, HSG C
12,095	98	Paved parking, HSG C
22,628	91	Weighted Average
6,530		28.86% Pervious Area
16,098		71.14% Impervious Area

Tc (min)	Length (feet)	Slope (ft/ft)	Velocity (ft/sec)	Capacity (cfs)	Description
6.0					Direct Entry, residential & parking areas

Subcatchment 2: CB-2 (mix)

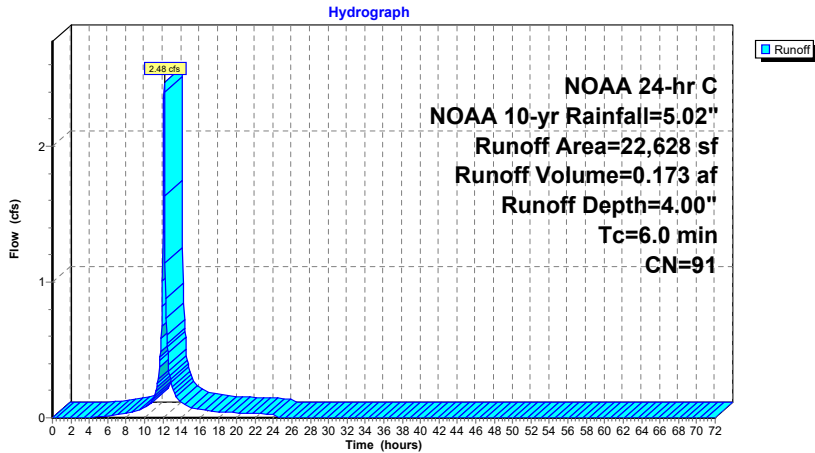

14850_Existing-Drainage-Areas

NOAA 24-hr C NOAA 10-yr Rainfall=5.02"

Prepared by {enter your company name here}

Printed 4/6/2022

HydroCAD® 10.10-7a s/n 00546 © 2021 HydroCAD Software Solutions LLC

Page 8

Summary for Subcatchment 3A: CB-3A (parking)

Runoff = 0.92 cfs @ 12.13 hrs, Volume= 0.071 af, Depth= 4.78"
Routed to Reach CB3 : EX-CB3

Runoff by SCS TR-20 method, UH=SCS, Weighted-CN, Time Span= 0.00-72.00 hrs, dt= 0.05 hrs
NOAA 24-hr C NOAA 10-yr Rainfall=5.02"

Area (sf)	CN	Description
7,758	98	Paved parking, HSG C
7,758		100.00% Impervious Area

Tc (min)	Length (feet)	Slope (ft/ft)	Velocity (ft/sec)	Capacity (cfs)	Description
6.0					Direct Entry, residential & parking areas

Subcatchment 3A: CB-3A (parking)

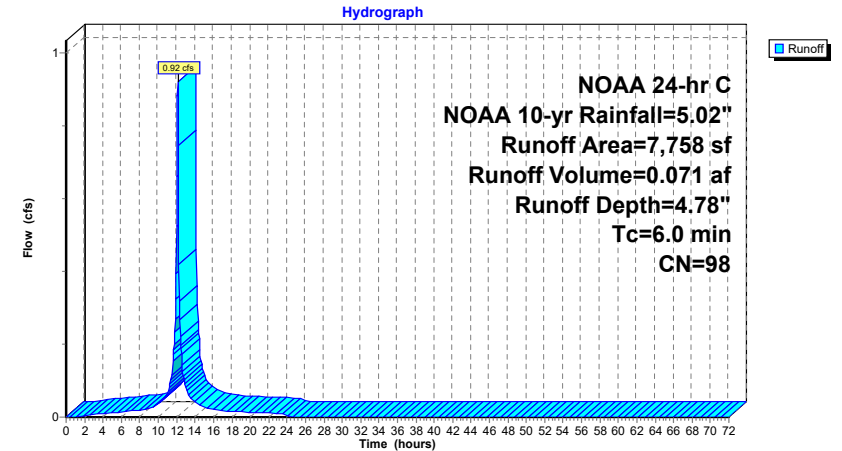

14850_Existing-Drainage-Areas

NOAA 24-hr C NOAA 10-yr Rainfall=5.02"

Prepared by {enter your company name here}

Printed 4/6/2022

HydroCAD® 10.10-7a s/n 00546 © 2021 HydroCAD Software Solutions LLC

Page 9

Summary for Subcatchment 3B: CB-3B (parking)

Runoff = 0.45 cfs @ 12.13 hrs, Volume= 0.035 af, Depth= 4.78"
Routed to Reach CB3 : EX-CB3

Runoff by SCS TR-20 method, UH=SCS, Weighted-CN, Time Span= 0.00-72.00 hrs, dt= 0.05 hrs
NOAA 24-hr C NOAA 10-yr Rainfall=5.02"

Area (sf)	CN	Description
3,797	98	Paved parking, HSG C
3,797		100.00% Impervious Area

Tc (min)	Length (feet)	Slope (ft/ft)	Velocity (ft/sec)	Capacity (cfs)	Description
6.0					Direct Entry, residential & parking areas

Subcatchment 3B: CB-3B (parking)

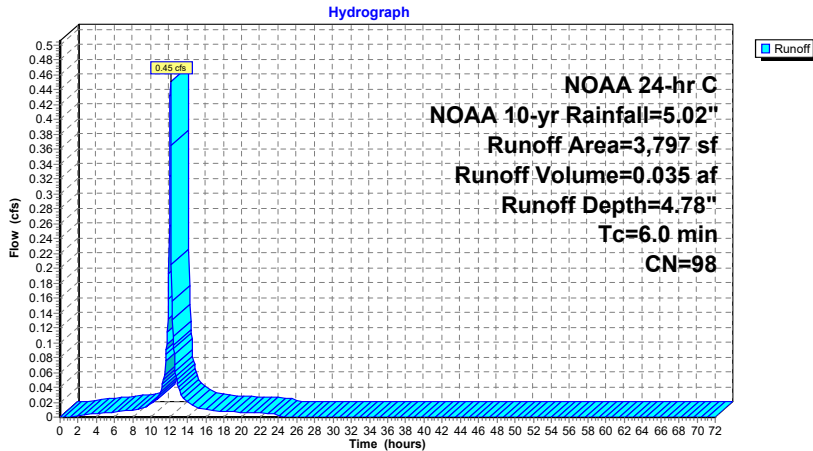

14850_Existing-Drainage-Areas

NOAA 24-hr C NOAA 10-yr Rainfall=5.02"

Prepared by {enter your company name here}

Printed 4/6/2022

HydroCAD® 10.10-7a s/n 00546 © 2021 HydroCAD Software Solutions LLC

Page 10

Summary for Subcatchment 5B: CB-5B (mix)

Runoff = 2.38 cfs @ 12.13 hrs, Volume= 0.162 af, Depth= 3.69"
Routed to Reach CB5 : EX-CB5

Runoff by SCS TR-20 method, UH=SCS, Weighted-CN, Time Span= 0.00-72.00 hrs, dt= 0.05 hrs
NOAA 24-hr C NOAA 10-yr Rainfall=5.02"

Area (sf)	CN	Description
15,743	83	1/4 acre lots, 38% imp, HSG C
7,231	98	Paved parking, HSG C
22,974	88	Weighted Average
9,761		42.49% Pervious Area
13,213		57.51% Impervious Area

Tc (min)	Length (feet)	Slope (ft/ft)	Velocity (ft/sec)	Capacity (cfs)	Description
6.0					Direct Entry, residential & parking areas

Subcatchment 5B: CB-5B (mix)

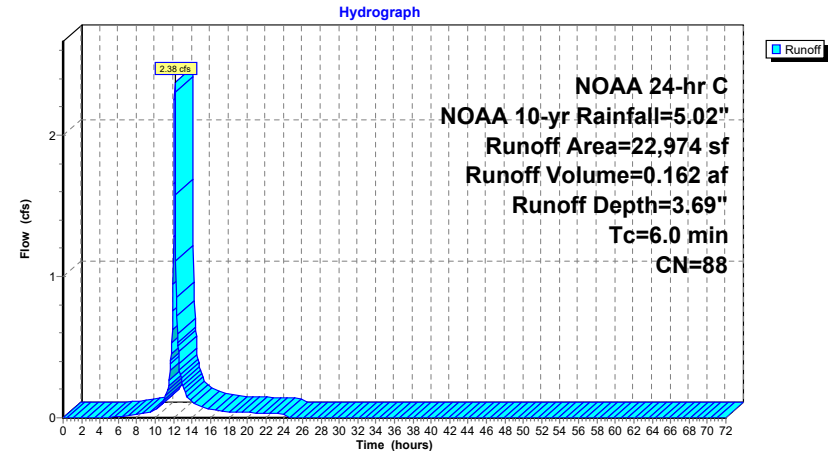

14850_Existing-Drainage-Areas

NOAA 24-hr C NOAA 10-yr Rainfall=5.02"

Prepared by {enter your company name here}

Printed 4/6/2022

HydroCAD® 10.10-7a s/n 00546 © 2021 HydroCAD Software Solutions LLC

Page 11

Summary for Subcatchment 6: CB-6 (mix)

Runoff = 4.05 cfs @ 12.13 hrs, Volume= 0.301 af, Depth= 4.55"
Routed to Reach CB6 : EX-CB6

Runoff by SCS TR-20 method, UH=SCS, Weighted-CN, Time Span= 0.00-72.00 hrs, dt= 0.05 hrs
NOAA 24-hr C NOAA 10-yr Rainfall=5.02"

Area (sf)	CN	Description
3,898	83	1/4 acre lots, 38% imp, HSG C
30,626	98	Paved parking, HSG C
34,524	96	Weighted Average
2,417		7.00% Pervious Area
32,107		93.00% Impervious Area

Tc (min)	Length (feet)	Slope (ft/ft)	Velocity (ft/sec)	Capacity (cfs)	Description
6.0					Direct Entry, residential & parking areas

Subcatchment 6: CB-6 (mix)

Hydrograph

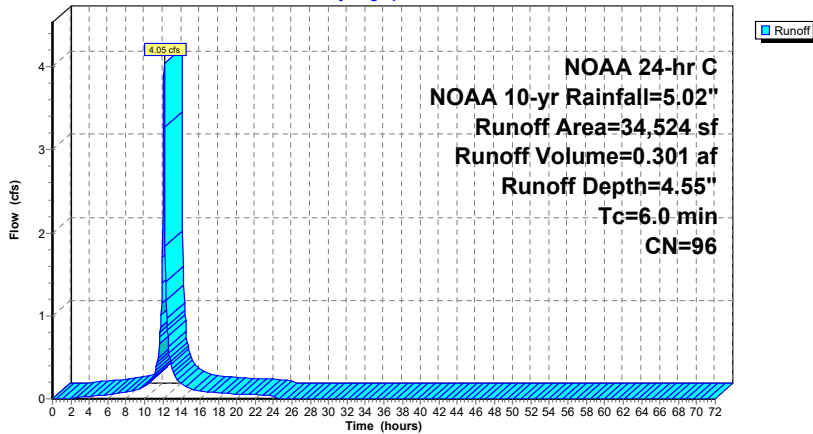

14850_Existing-Drainage-Areas

NOAA 24-hr C NOAA 10-yr Rainfall=5.02"

Prepared by {enter your company name here}

Printed 4/6/2022

HydroCAD® 10.10-7a s/n 00546 © 2021 HydroCAD Software Solutions LLC

Page 12

Summary for Subcatchment 8B: CB-8B (mix)

Runoff = 2.89 cfs @ 12.13 hrs, Volume= 0.196 af, Depth= 3.59"
Routed to Reach CB8 : EX-CB8

Runoff by SCS TR-20 method, UH=SCS, Weighted-CN, Time Span= 0.00-72.00 hrs, dt= 0.05 hrs
NOAA 24-hr C NOAA 10-yr Rainfall=5.02"

Area (sf)	CN	Description
20,925	83	1/4 acre lots, 38% imp, HSG C
7,603	98	Paved parking, HSG C
28,528	87	Weighted Average
12,974		45.48% Pervious Area
15,555		54.52% Impervious Area

Tc (min)	Length (feet)	Slope (ft/ft)	Velocity (ft/sec)	Capacity (cfs)	Description
6.0					Direct Entry, residential & parking areas

Subcatchment 8B: CB-8B (mix)

Hydrograph

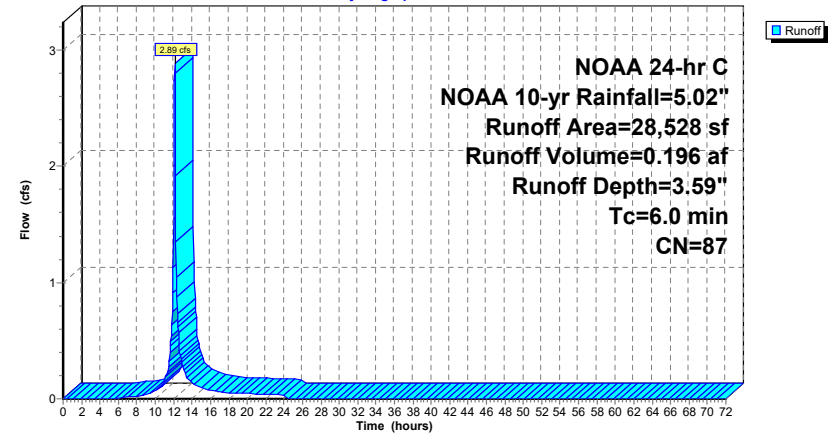

14850_Existing-Drainage-Areas

NOAA 24-hr C NOAA 10-yr Rainfall=5.02"

Prepared by {enter your company name here}

Printed 4/6/2022

HydroCAD® 10.10-7a s/n 00546 © 2021 HydroCAD Software Solutions LLC

Page 13

Summary for Subcatchment 9: CB-9 (mix)

Runoff = 4.27 cfs @ 12.13 hrs, Volume= 0.322 af, Depth= 4.67"
 Routed to Reach CB9 : EX CB-9

Runoff by SCS TR-20 method, UH=SCS, Weighted-CN, Time Span= 0.00-72.00 hrs, dt= 0.05 hrs
 NOAA 24-hr C NOAA 10-yr Rainfall=5.02"

Area (sf)	CN	Description
3,474	83	1/4 acre lots, 38% imp, HSG C
32,630	98	Paved parking, HSG C
36,104	97	Weighted Average
2,154		5.97% Pervious Area
33,950		94.03% Impervious Area

Tc (min)	Length (feet)	Slope (ft/ft)	Velocity (ft/sec)	Capacity (cfs)	Description
6.0					Direct Entry, residential & parking areas

Subcatchment 9: CB-9 (mix)

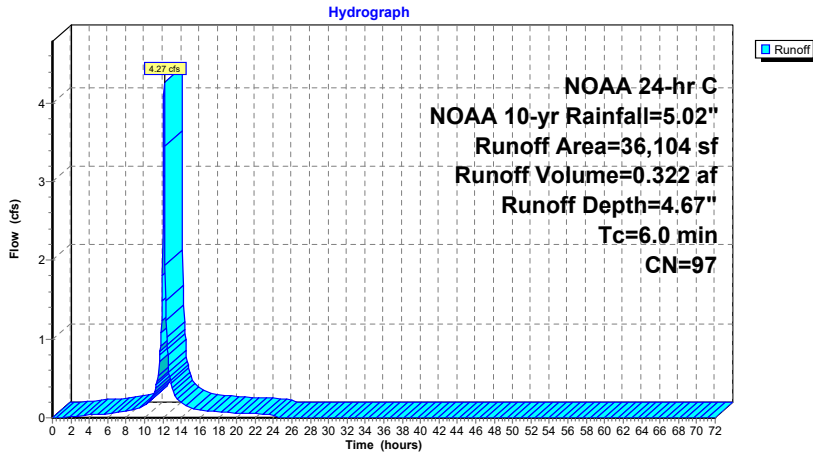

14850_Existing-Drainage-Areas

NOAA 24-hr C NOAA 10-yr Rainfall=5.02"

Prepared by {enter your company name here}

Printed 4/6/2022

HydroCAD® 10.10-7a s/n 00546 © 2021 HydroCAD Software Solutions LLC

Page 14

Summary for Subcatchment 10: CB-10 (parking)

Runoff = 0.77 cfs @ 12.13 hrs, Volume= 0.059 af, Depth= 4.78"
 Routed to Reach CB10 : EX-CB10

Runoff by SCS TR-20 method, UH=SCS, Weighted-CN, Time Span= 0.00-72.00 hrs, dt= 0.05 hrs
 NOAA 24-hr C NOAA 10-yr Rainfall=5.02"

Area (sf)	CN	Description
6,492	98	Paved parking, HSG C
6,492		100.00% Impervious Area

Tc (min)	Length (feet)	Slope (ft/ft)	Velocity (ft/sec)	Capacity (cfs)	Description
6.0					Direct Entry, residential & parking areas

Subcatchment 10: CB-10 (parking)

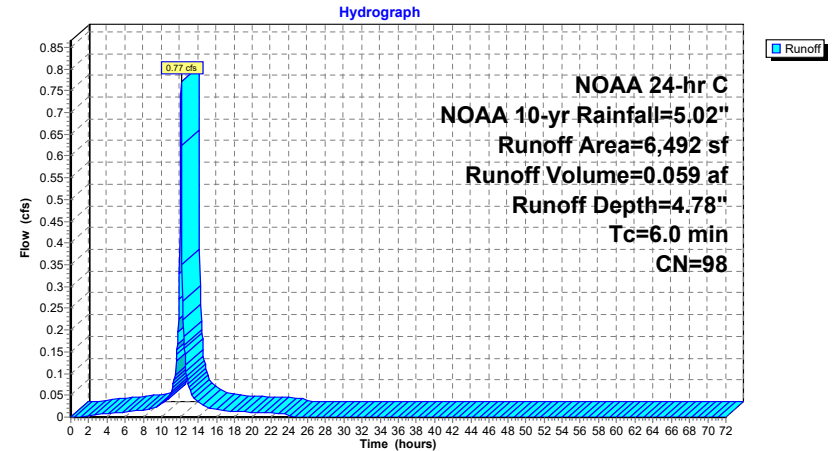

14850_Existing-Drainage-Areas

NOAA 24-hr C NOAA 10-yr Rainfall=5.02"

Prepared by {enter your company name here}

Printed 4/6/2022

HydroCAD® 10.10-7a s/n 00546 © 2021 HydroCAD Software Solutions LLC

Page 15

Summary for Subcatchment CB-1: New CB South (Seymour Street)

Runoff = 2.03 cfs @ 12.13 hrs, Volume= 0.138 af, Depth= 3.69"
Routed to Reach CB4 : EX-CB4

Runoff by SCS TR-20 method, UH=SCS, Weighted-CN, Time Span= 0.00-72.00 hrs, dt= 0.05 hrs
NOAA 24-hr C NOAA 10-yr Rainfall=5.02"

Area (sf)	CN	Description
13,211	83	1/4 acre lots, 38% imp, HSG C
* 6,371	98	Roadway
19,582	88	Weighted Average
8,191		41.83% Pervious Area
11,391		58.17% Impervious Area

Tc (min)	Length (feet)	Slope (ft/ft)	Velocity (ft/sec)	Capacity (cfs)	Description
0.6	50	0.0300	1.45		Sheet Flow, A-B Smooth surfaces n= 0.011 P2= 3.40"
2.4	462	0.0249	3.20		Shallow Concentrated Flow, Paved Paved Kv= 20.3 fps
3.0					Direct Entry, Direct entry to 6
6.0	512	Total			

Subcatchment CB-1: New CB South (Seymour Street)

Hydrograph

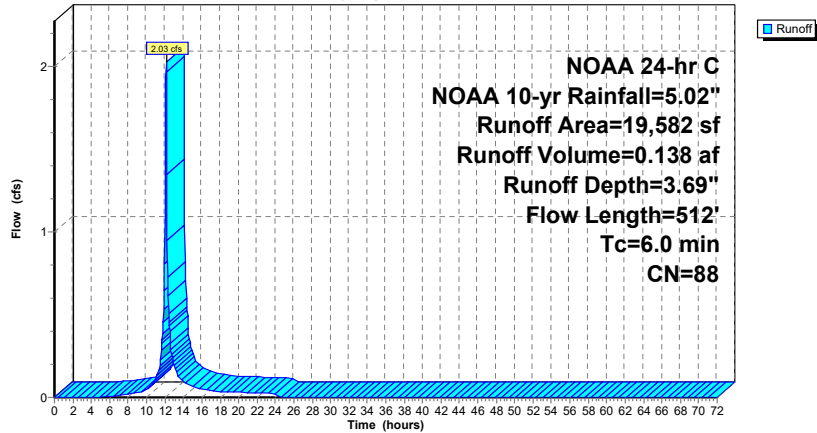

14850_Existing-Drainage-Areas

NOAA 24-hr C NOAA 10-yr Rainfall=5.02"

Prepared by {enter your company name here}

Printed 4/6/2022

HydroCAD® 10.10-7a s/n 00546 © 2021 HydroCAD Software Solutions LLC

Page 16

Summary for Subcatchment CB-3: NEW CB SOUTH- HUDSON ST

Runoff = 2.49 cfs @ 12.13 hrs, Volume= 0.168 af, Depth= 3.49"
Routed to Reach CB7 : EX-CB7

Runoff by SCS TR-20 method, UH=SCS, Weighted-CN, Time Span= 0.00-72.00 hrs, dt= 0.05 hrs
NOAA 24-hr C NOAA 10-yr Rainfall=5.02"

Area (sf)	CN	Description
19,562	83	1/4 acre lots, 38% imp, HSG C
* 5,621	98	Roadway
25,183	86	Weighted Average
12,128		48.16% Pervious Area
13,055		51.84% Impervious Area

Tc (min)	Length (feet)	Slope (ft/ft)	Velocity (ft/sec)	Capacity (cfs)	Description
0.5	50	0.0444	1.70		Sheet Flow, A-B (sheet flow) Smooth surfaces n= 0.011 P2= 3.40"
3.0	585	0.0256	3.25		Shallow Concentrated Flow, B-C Paved Kv= 20.3 fps
2.5					Direct Entry, direct entry to 6
6.0	635	Total			

Subcatchment CB-3: NEW CB SOUTH- HUDSON ST

Hydrograph

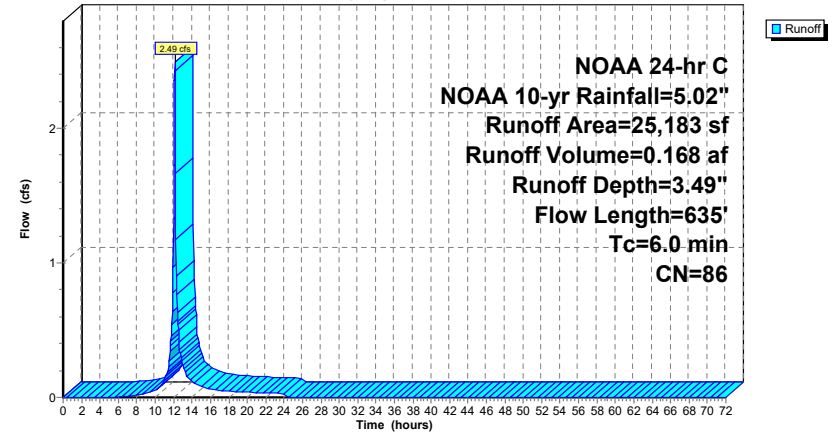

14850_Existing-Drainage-Areas

NOAA 24-hr C NOAA 10-yr Rainfall=5.02"

Prepared by {enter your company name here}

Printed 4/6/2022

HydroCAD® 10.10-7a s/n 00546 © 2021 HydroCAD Software Solutions LLC

Page 17

Summary for Subcatchment CB-4: NEW CB NOTH - HUDSON STREET

Runoff = 11.70 cfs @ 12.13 hrs, Volume= 0.788 af, Depth= 3.49"
Routed to Reach CB8 : EX-CB8

Runoff by SCS TR-20 method, UH=SCS, Weighted-CN, Time Span= 0.00-72.00 hrs, dt= 0.05 hrs
NOAA 24-hr C NOAA 10-yr Rainfall=5.02"

Area (sf)	CN	Description
96,716	83	1/4 acre lots, 38% imp, HSG C
* 21,410	98	Roadway
118,126	86	Weighted Average
59,964		50.76% Pervious Area
58,162		49.24% Impervious Area

Tc (min)	Length (feet)	Slope (ft/ft)	Velocity (ft/sec)	Capacity (cfs)	Description
0.5	50	0.0500	1.78		Sheet Flow, A-B (sheet flow) Smooth surfaces n= 0.011 P2= 3.40"
4.0	772	0.0245	3.18		Shallow Concentrated Flow, B-C (shallow concentrated) Paved Kv= 20.3 fps
1.5					Direct Entry, direct entry to 6
6.0	822	Total			

Subcatchment CB-4: NEW CB NOTH - HUDSON STREET

Hydrograph

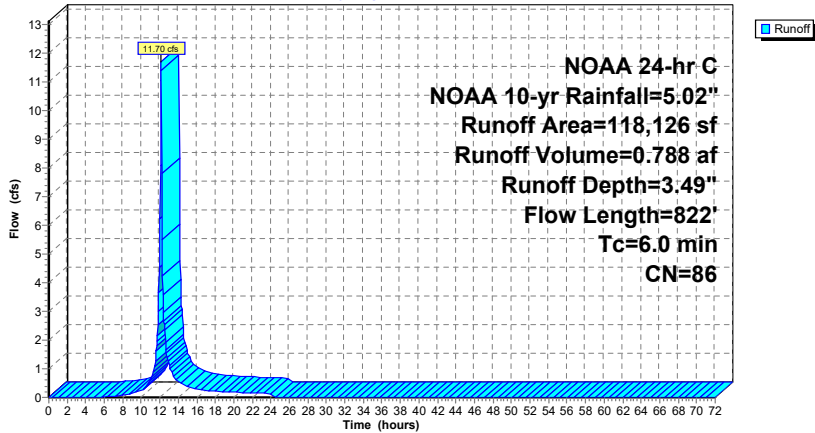

14850_Existing-Drainage-Areas

NOAA 24-hr C NOAA 10-yr Rainfall=5.02"

Prepared by {enter your company name here}

Printed 4/6/2022

HydroCAD® 10.10-7a s/n 00546 © 2021 HydroCAD Software Solutions LLC

Page 18

Summary for Subcatchment CB-5: NEW CB - PORTLAND ST SOUTH

Runoff = 1.96 cfs @ 12.13 hrs, Volume= 0.132 af, Depth= 3.49"
Routed to Reach CB11 : EX-CB11

Runoff by SCS TR-20 method, UH=SCS, Weighted-CN, Time Span= 0.00-72.00 hrs, dt= 0.05 hrs
NOAA 24-hr C NOAA 10-yr Rainfall=5.02"

Area (sf)	CN	Description
15,657	83	1/4 acre lots, 38% imp, HSG C
* 4,086	98	Roadway
19,743	86	Weighted Average
9,707		49.17% Pervious Area
10,036		50.83% Impervious Area

Tc (min)	Length (feet)	Slope (ft/ft)	Velocity (ft/sec)	Capacity (cfs)	Description
0.5	50	0.0500	1.78		Sheet Flow, A-B (sheet flow) Smooth surfaces n= 0.011 P2= 3.40"
2.3	524	0.0346	3.78		Shallow Concentrated Flow, B-C (shallow conc.) Paved Kv= 20.3 fps
3.2					Direct Entry, direct to 6
6.0	574	Total			

Subcatchment CB-5: NEW CB - PORTLAND ST SOUTH

Hydrograph

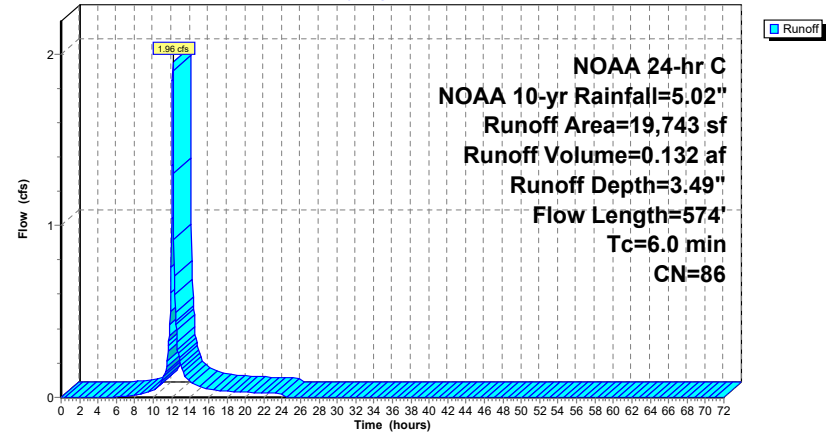

14850_Existing-Drainage-Areas

NOAA 24-hr C NOAA 10-yr Rainfall=5.02"

Prepared by {enter your company name here}

Printed 4/6/2022

HydroCAD® 10.10-7a s/n 00546 © 2021 HydroCAD Software Solutions LLC

Page 19

Summary for Reach CB1: EX CB-1

[40] Hint: Not Described (Outflow=Inflow)

Inflow Area = 0.760 ac, 61.34% Impervious, Inflow Depth = 3.79" for NOAA 10-yr event
Inflow = 3.50 cfs @ 12.13 hrs, Volume= 0.240 af
Outflow = 3.50 cfs @ 12.13 hrs, Volume= 0.240 af, Atten= 0%, Lag= 0.0 min
Routed to Reach DP-1 : French Rodney Blvd 14" Outfall

Routing by Stor-Ind+Trans method, Time Span= 0.00-72.00 hrs, dt= 0.05 hrs

Reach CB1: EX CB-1

Hydrograph

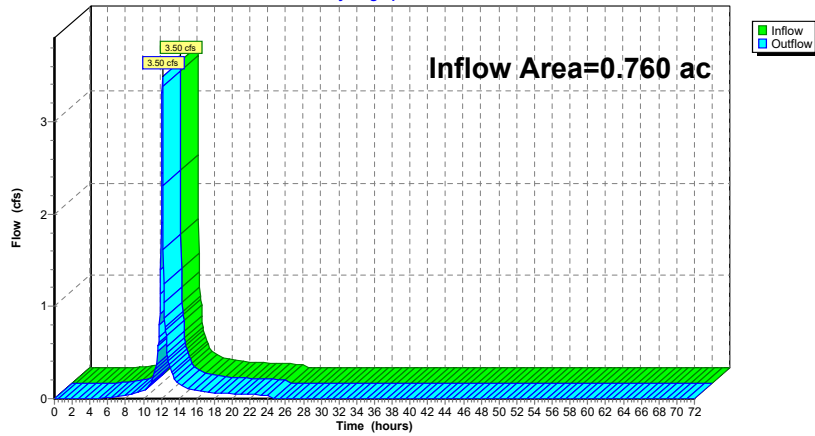

14850_Existing-Drainage-Areas

NOAA 24-hr C NOAA 10-yr Rainfall=5.02"

Prepared by {enter your company name here}

Printed 4/6/2022

HydroCAD® 10.10-7a s/n 00546 © 2021 HydroCAD Software Solutions LLC

Page 20

Summary for Reach CB10: EX-CB10

[40] Hint: Not Described (Outflow=Inflow)

Inflow Area = 0.149 ac, 100.00% Impervious, Inflow Depth = 4.78" for NOAA 10-yr event
Inflow = 0.77 cfs @ 12.13 hrs, Volume= 0.059 af
Outflow = 0.77 cfs @ 12.13 hrs, Volume= 0.059 af, Atten= 0%, Lag= 0.0 min
Routed to Reach DP-2 : PORTLAND STREET DRAINAGE

Routing by Stor-Ind+Trans method, Time Span= 0.00-72.00 hrs, dt= 0.05 hrs

Reach CB10: EX-CB10

Hydrograph

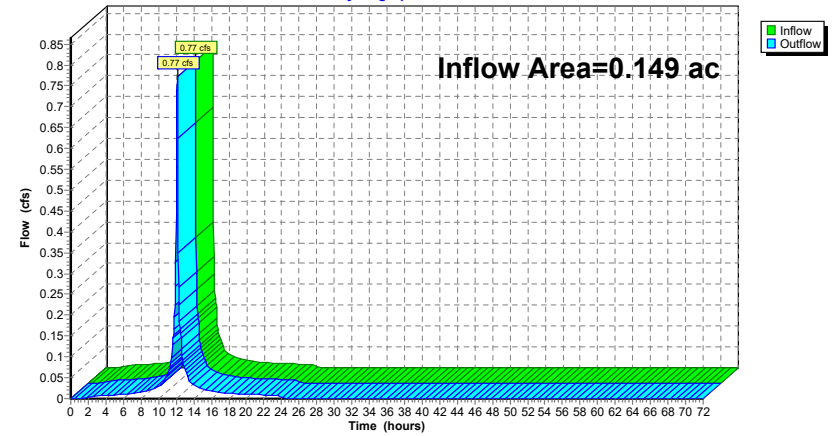

14850_Existing-Drainage-Areas

NOAA 24-hr C NOAA 10-yr Rainfall=5.02"

Prepared by {enter your company name here}

Printed 4/6/2022

HydroCAD® 10.10-7a s/n 00546 © 2021 HydroCAD Software Solutions LLC

Page 21

Summary for Reach CB11: EX-CB11

[40] Hint: Not Described (Outflow=Inflow)

Inflow Area = 0.453 ac, 50.83% Impervious, Inflow Depth = 3.49" for NOAA 10-yr event
Inflow = 1.96 cfs @ 12.13 hrs, Volume= 0.132 af
Outflow = 1.96 cfs @ 12.13 hrs, Volume= 0.132 af, Atten= 0%, Lag= 0.0 min
Routed to Reach DP-2 : PORTLAND STREET DRAINAGE

Routing by Stor-Ind+Trans method, Time Span= 0.00-72.00 hrs, dt= 0.05 hrs

Reach CB11: EX-CB11

Hydrograph

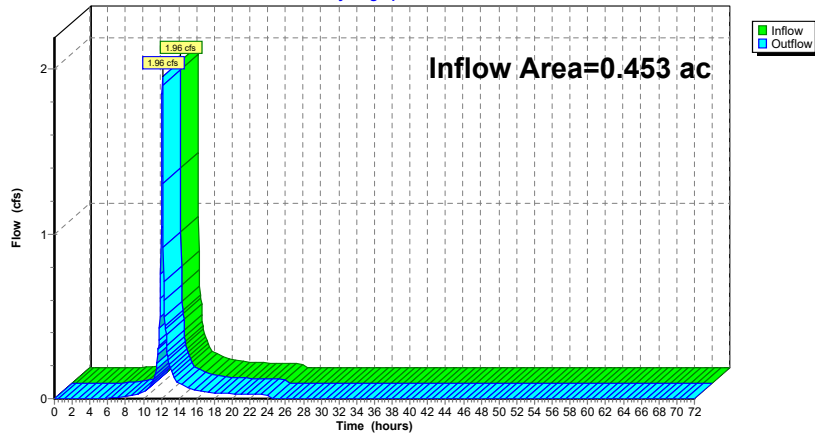

14850_Existing-Drainage-Areas

NOAA 24-hr C NOAA 10-yr Rainfall=5.02"

Prepared by {enter your company name here}

Printed 4/6/2022

HydroCAD® 10.10-7a s/n 00546 © 2021 HydroCAD Software Solutions LLC

Page 22

Summary for Reach CB2: EX-CB2

[40] Hint: Not Described (Outflow=Inflow)

Inflow Area = 0.519 ac, 71.14% Impervious, Inflow Depth = 4.00" for NOAA 10-yr event
Inflow = 2.48 cfs @ 12.13 hrs, Volume= 0.173 af
Outflow = 2.48 cfs @ 12.13 hrs, Volume= 0.173 af, Atten= 0%, Lag= 0.0 min
Routed to Reach DP-1 : French Rodney Blvd 14" Outfall

Routing by Stor-Ind+Trans method, Time Span= 0.00-72.00 hrs, dt= 0.05 hrs

Reach CB2: EX-CB2

Hydrograph

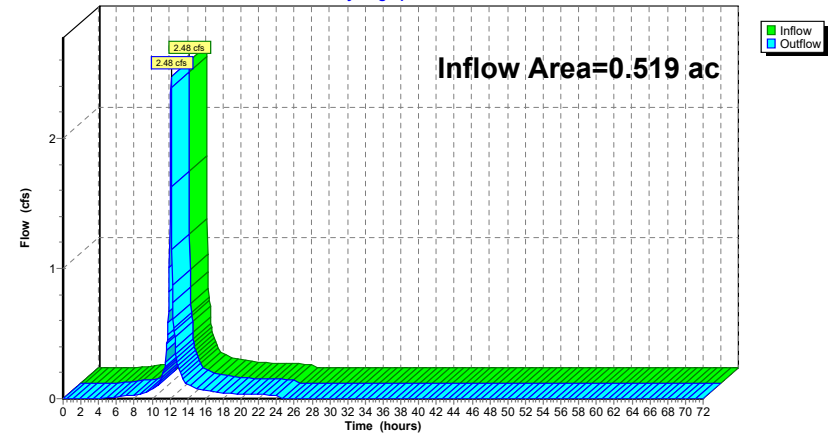

14850_Existing-Drainage-Areas

NOAA 24-hr C NOAA 10-yr Rainfall=5.02"

Prepared by {enter your company name here}

Printed 4/6/2022

HydroCAD® 10.10-7a s/n 00546 © 2021 HydroCAD Software Solutions LLC

Page 23

Summary for Reach CB3: EX-CB3

[40] Hint: Not Described (Outflow=Inflow)

Inflow Area = 0.265 ac, 100.00% Impervious, Inflow Depth = 4.78" for NOAA 10-yr event
Inflow = 1.37 cfs @ 12.13 hrs, Volume= 0.106 af
Outflow = 1.37 cfs @ 12.13 hrs, Volume= 0.106 af, Atten= 0%, Lag= 0.0 min
Routed to Reach DP-1 : French Rodney Blvd 14" Outfall

Routing by Stor-Ind+Trans method, Time Span= 0.00-72.00 hrs, dt= 0.05 hrs

Reach CB3: EX-CB3

Hydrograph

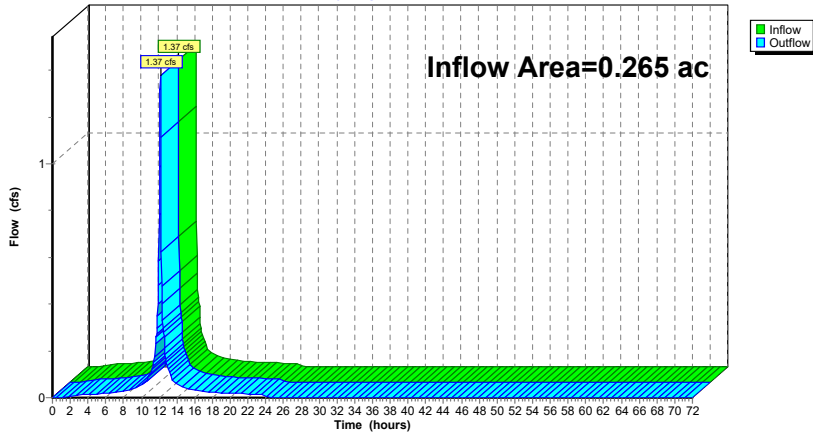

14850_Existing-Drainage-Areas

NOAA 24-hr C NOAA 10-yr Rainfall=5.02"

Prepared by {enter your company name here}

Printed 4/6/2022

HydroCAD® 10.10-7a s/n 00546 © 2021 HydroCAD Software Solutions LLC

Page 24

Summary for Reach CB4: EX-CB4

[40] Hint: Not Described (Outflow=Inflow)

Inflow Area = 0.450 ac, 58.17% Impervious, Inflow Depth = 3.69" for NOAA 10-yr event
Inflow = 2.03 cfs @ 12.13 hrs, Volume= 0.138 af
Outflow = 2.03 cfs @ 12.13 hrs, Volume= 0.138 af, Atten= 0%, Lag= 0.0 min
Routed to Reach DP-1 : French Rodney Blvd 14" Outfall

Routing by Stor-Ind+Trans method, Time Span= 0.00-72.00 hrs, dt= 0.05 hrs

Reach CB4: EX-CB4

Hydrograph

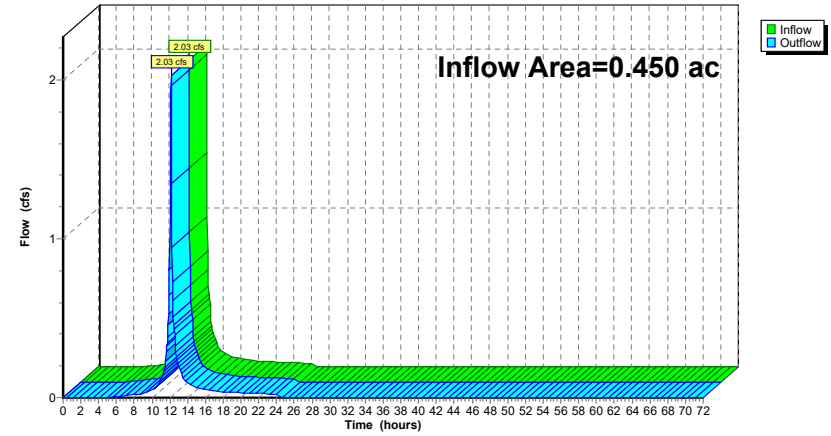

14850_Existing-Drainage-Areas

NOAA 24-hr C NOAA 10-yr Rainfall=5.02"

Prepared by {enter your company name here}

Printed 4/6/2022

HydroCAD® 10.10-7a s/n 00546 © 2021 HydroCAD Software Solutions LLC

Page 25

Summary for Reach CB5: EX-CB5

[40] Hint: Not Described (Outflow=Inflow)

Inflow Area = 0.527 ac, 57.51% Impervious, Inflow Depth = 3.69" for NOAA 10-yr event
Inflow = 2.38 cfs @ 12.13 hrs, Volume= 0.162 af
Outflow = 2.38 cfs @ 12.13 hrs, Volume= 0.162 af, Atten= 0%, Lag= 0.0 min
Routed to Reach DP-2 : PORTLAND STREET DRAINAGE

Routing by Stor-Ind+Trans method, Time Span= 0.00-72.00 hrs, dt= 0.05 hrs

Reach CB5: EX-CB5

Hydrograph

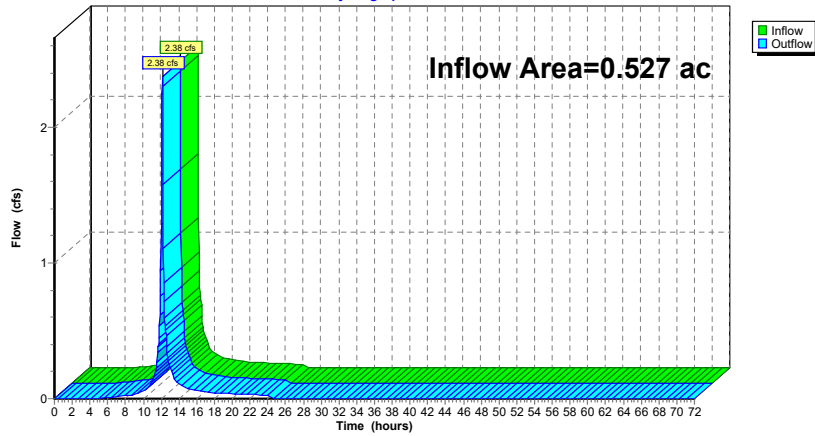

14850_Existing-Drainage-Areas

NOAA 24-hr C NOAA 10-yr Rainfall=5.02"

Prepared by {enter your company name here}

Printed 4/6/2022

HydroCAD® 10.10-7a s/n 00546 © 2021 HydroCAD Software Solutions LLC

Page 26

Summary for Reach CB6: EX-CB6

[40] Hint: Not Described (Outflow=Inflow)

Inflow Area = 0.793 ac, 93.00% Impervious, Inflow Depth = 4.55" for NOAA 10-yr event
Inflow = 4.05 cfs @ 12.13 hrs, Volume= 0.301 af
Outflow = 4.05 cfs @ 12.13 hrs, Volume= 0.301 af, Atten= 0%, Lag= 0.0 min
Routed to Reach DP-2 : PORTLAND STREET DRAINAGE

Routing by Stor-Ind+Trans method, Time Span= 0.00-72.00 hrs, dt= 0.05 hrs

Reach CB6: EX-CB6

Hydrograph

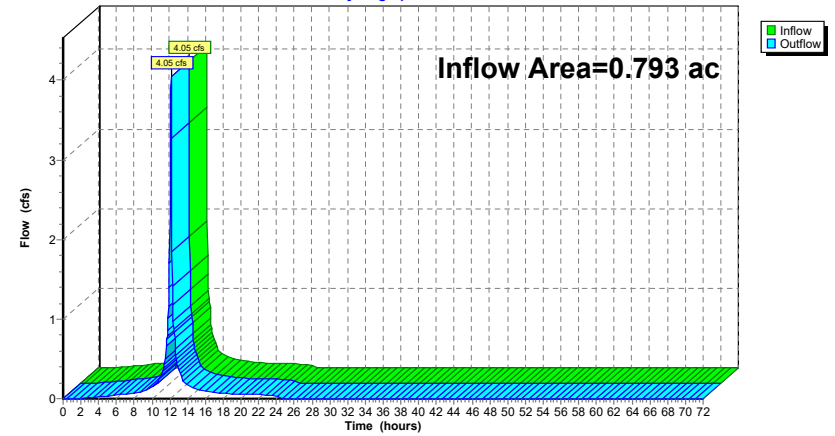

14850_Existing-Drainage-Areas

NOAA 24-hr C NOAA 10-yr Rainfall=5.02"

Prepared by {enter your company name here}

Printed 4/6/2022

HydroCAD® 10.10-7a s/n 00546 © 2021 HydroCAD Software Solutions LLC

Page 27

Summary for Reach CB7: EX-CB7

[40] Hint: Not Described (Outflow=Inflow)

Inflow Area = 0.578 ac, 51.84% Impervious, Inflow Depth = 3.49" for NOAA 10-yr event
Inflow = 2.49 cfs @ 12.13 hrs, Volume= 0.168 af
Outflow = 2.49 cfs @ 12.13 hrs, Volume= 0.168 af, Atten= 0%, Lag= 0.0 min
Routed to Reach DP-2 : PORTLAND STREET DRAINAGE

Routing by Stor-Ind+Trans method, Time Span= 0.00-72.00 hrs, dt= 0.05 hrs

Reach CB7: EX-CB7

Hydrograph

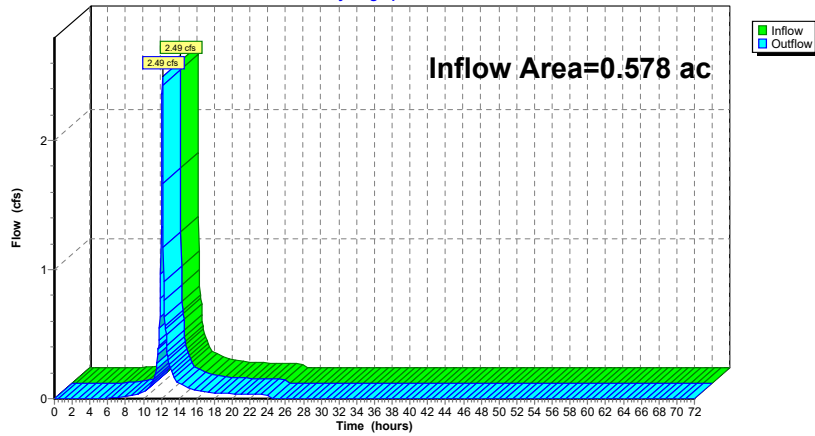

14850_Existing-Drainage-Areas

NOAA 24-hr C NOAA 10-yr Rainfall=5.02"

Prepared by {enter your company name here}

Printed 4/6/2022

HydroCAD® 10.10-7a s/n 00546 © 2021 HydroCAD Software Solutions LLC

Page 28

Summary for Reach CB8: EX-CB8

[40] Hint: Not Described (Outflow=Inflow)

Inflow Area = 3.367 ac, 50.27% Impervious, Inflow Depth = 3.51" for NOAA 10-yr event
Inflow = 14.59 cfs @ 12.13 hrs, Volume= 0.983 af
Outflow = 14.59 cfs @ 12.13 hrs, Volume= 0.983 af, Atten= 0%, Lag= 0.0 min
Routed to Reach DP-2 : PORTLAND STREET DRAINAGE

Routing by Stor-Ind+Trans method, Time Span= 0.00-72.00 hrs, dt= 0.05 hrs

Reach CB8: EX-CB8

Hydrograph

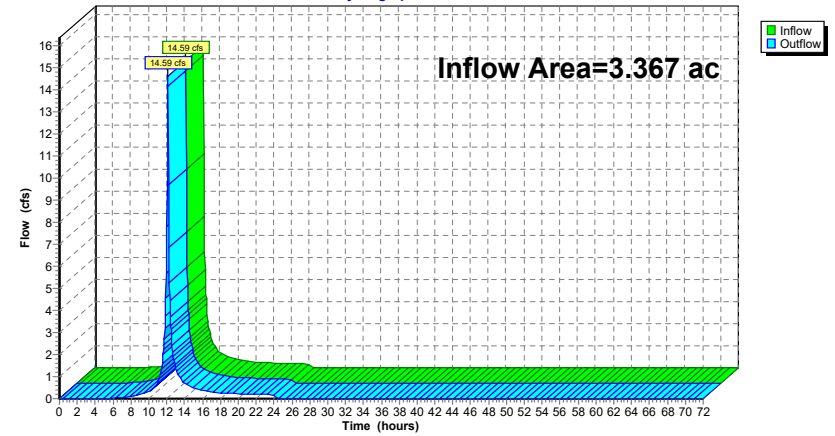

14850_Existing-Drainage-Areas

NOAA 24-hr C NOAA 10-yr Rainfall=5.02"

Prepared by {enter your company name here}

Printed 4/6/2022

HydroCAD® 10.10-7a s/n 00546 © 2021 HydroCAD Software Solutions LLC

Page 29

Summary for Reach CB9: EX CB-9

[40] Hint: Not Described (Outflow=Inflow)

Inflow Area = 0.829 ac, 94.03% Impervious, Inflow Depth = 4.67" for NOAA 10-yr event
Inflow = 4.27 cfs @ 12.13 hrs, Volume= 0.322 af
Outflow = 4.27 cfs @ 12.13 hrs, Volume= 0.322 af, Atten= 0%, Lag= 0.0 min
Routed to Reach DP-2 : PORTLAND STREET DRAINAGE

Routing by Stor-Ind+Trans method, Time Span= 0.00-72.00 hrs, dt= 0.05 hrs

Reach CB9: EX CB-9

Hydrograph

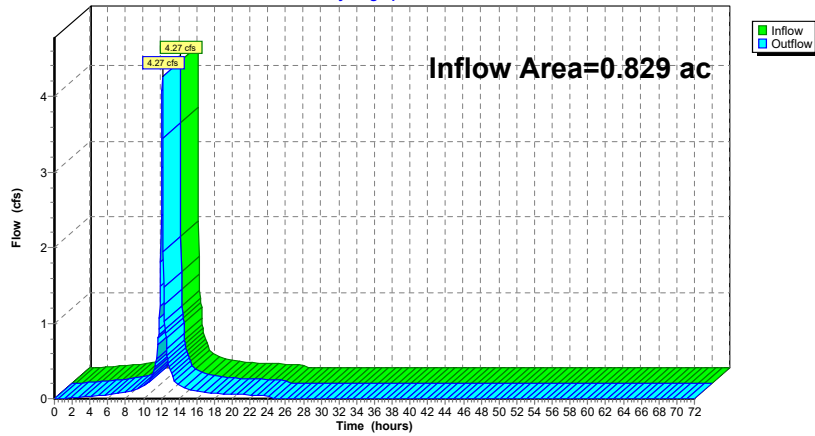

14850_Existing-Drainage-Areas

NOAA 24-hr C NOAA 10-yr Rainfall=5.02"

Prepared by {enter your company name here}

Printed 4/6/2022

HydroCAD® 10.10-7a s/n 00546 © 2021 HydroCAD Software Solutions LLC

Page 30

Summary for Reach DP-1: French Rodney Blvd 14" Outfall

[40] Hint: Not Described (Outflow=Inflow)

Inflow Area = 1.994 ac, 68.32% Impervious, Inflow Depth = 3.95" for NOAA 10-yr event
Inflow = 9.38 cfs @ 12.13 hrs, Volume= 0.657 af
Outflow = 9.38 cfs @ 12.13 hrs, Volume= 0.657 af, Atten= 0%, Lag= 0.0 min

Routing by Stor-Ind+Trans method, Time Span= 0.00-72.00 hrs, dt= 0.05 hrs

Reach DP-1: French Rodney Blvd 14" Outfall

Hydrograph

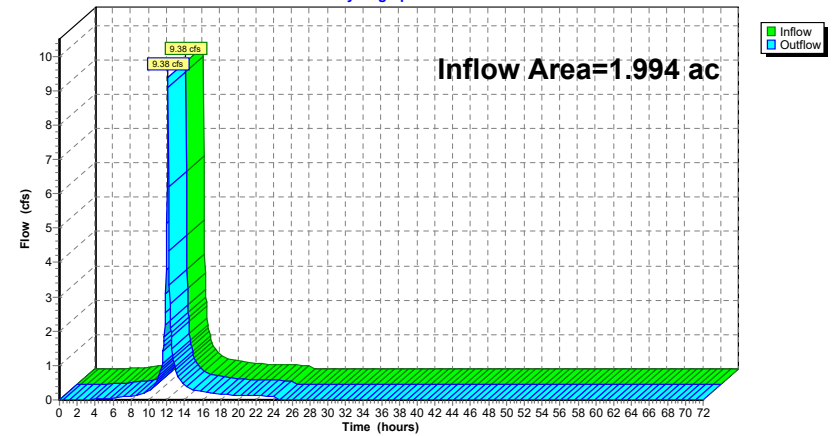

14850_Existing-Drainage-Areas

NOAA 24-hr C NOAA 10-yr Rainfall=5.02"

Prepared by {enter your company name here}

Printed 4/6/2022

HydroCAD® 10.10-7a s/n 00546 © 2021 HydroCAD Software Solutions LLC

Page 31

Summary for Reach DP-2: PORTLAND STREET DRAINAGE

[40] Hint: Not Described (Outflow=Inflow)

Inflow Area = 6.696 ac, 62.59% Impervious, Inflow Depth = 3.81" for NOAA 10-yr event
 Inflow = 30.51 cfs @ 12.13 hrs, Volume= 2.128 af
 Outflow = 30.51 cfs @ 12.13 hrs, Volume= 2.128 af, Atten= 0%, Lag= 0.0 min

Routing by Stor-Ind+Trans method, Time Span= 0.00-72.00 hrs, dt= 0.05 hrs

Reach DP-2: PORTLAND STREET DRAINAGE

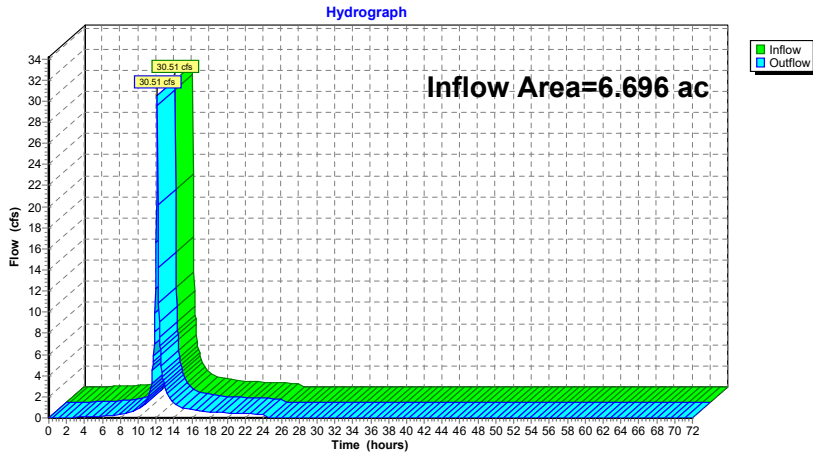

14850_Existing-Drainage-Areas

NOAA 24-hr C NOAA 100-yr Rainfall=7.59"

Prepared by {enter your company name here}

Printed 4/6/2022

HydroCAD® 10.10-7a s/n 00546 © 2021 HydroCAD Software Solutions LLC

Page 32

Time span=0.00-72.00 hrs, dt=0.05 hrs, 1441 points

Runoff by SCS TR-20 method, UH=SCS, Weighted-CN

Reach routing by Stor-Ind+Trans method - Pond routing by Stor-Ind method

Subcatchment1B: CB-1B (mix)	Runoff Area=33,097 sf 61.34% Impervious Runoff Depth=6.28" Tc=6.0 min CN=89 Runoff=5.61 cfs 0.398 af
Subcatchment2: CB-2 (mix)	Runoff Area=22,628 sf 71.14% Impervious Runoff Depth=6.52" Tc=6.0 min CN=91 Runoff=3.91 cfs 0.282 af
Subcatchment3A: CB-3A (parking)	Runoff Area=7,758 sf 100.00% Impervious Runoff Depth=7.35" Tc=6.0 min CN=98 Runoff=1.40 cfs 0.109 af
Subcatchment3B: CB-3B (parking)	Runoff Area=3,797 sf 100.00% Impervious Runoff Depth=7.35" Tc=6.0 min CN=98 Runoff=0.69 cfs 0.053 af
Subcatchment5B: CB-5B (mix)	Runoff Area=22,974 sf 57.51% Impervious Runoff Depth=6.17" Tc=6.0 min CN=88 Runoff=3.85 cfs 0.271 af
Subcatchment6: CB-6 (mix)	Runoff Area=34,524 sf 93.00% Impervious Runoff Depth=7.11" Tc=6.0 min CN=96 Runoff=6.18 cfs 0.470 af
Subcatchment8B: CB-8B (mix)	Runoff Area=28,528 sf 54.52% Impervious Runoff Depth=6.05" Tc=6.0 min CN=87 Runoff=4.73 cfs 0.330 af
Subcatchment9: CB-9 (mix)	Runoff Area=36,104 sf 94.03% Impervious Runoff Depth=7.23" Tc=6.0 min CN=97 Runoff=6.49 cfs 0.499 af
Subcatchment10: CB-10 (parking)	Runoff Area=6,492 sf 100.00% Impervious Runoff Depth=7.35" Tc=6.0 min CN=98 Runoff=1.17 cfs 0.091 af
SubcatchmentCB-1: New CB South	Runoff Area=19,582 sf 58.17% Impervious Runoff Depth=6.17" Flow Length=512' Tc=6.0 min CN=88 Runoff=3.28 cfs 0.231 af
SubcatchmentCB-3: NEW CB SOUTH-	Runoff Area=25,183 sf 51.84% Impervious Runoff Depth=5.93" Flow Length=635' Tc=6.0 min CN=86 Runoff=4.12 cfs 0.286 af
SubcatchmentCB-4: NEW CB NOTH -	Runoff Area=118,126 sf 49.24% Impervious Runoff Depth=5.93" Flow Length=822' Tc=6.0 min CN=86 Runoff=19.32 cfs 1.341 af
SubcatchmentCB-5: NEW CB -	Runoff Area=19,743 sf 50.83% Impervious Runoff Depth=5.93" Flow Length=574' Tc=6.0 min CN=86 Runoff=3.23 cfs 0.224 af
Reach CB1: EX CB-1	Inflow=5.61 cfs 0.398 af Outflow=5.61 cfs 0.398 af
Reach CB10: EX-CB10	Inflow=1.17 cfs 0.091 af Outflow=1.17 cfs 0.091 af
Reach CB11: EX-CB11	Inflow=3.23 cfs 0.224 af Outflow=3.23 cfs 0.224 af

14850_Existing-Drainage-Areas

NOAA 24-hr C NOAA 100-yr Rainfall=7.59"

Prepared by {enter your company name here}

Printed 4/6/2022

HydroCAD® 10.10-7a s/n 00546 © 2021 HydroCAD Software Solutions LLC

Page 33

Reach CB2: EX-CB2	Inflow=3.91 cfs 0.282 af Outflow=3.91 cfs 0.282 af
Reach CB3: EX-CB3	Inflow=2.08 cfs 0.162 af Outflow=2.08 cfs 0.162 af
Reach CB4: EX-CB4	Inflow=3.28 cfs 0.231 af Outflow=3.28 cfs 0.231 af
Reach CB5: EX-CB5	Inflow=3.85 cfs 0.271 af Outflow=3.85 cfs 0.271 af
Reach CB6: EX-CB6	Inflow=6.18 cfs 0.470 af Outflow=6.18 cfs 0.470 af
Reach CB7: EX-CB7	Inflow=4.12 cfs 0.286 af Outflow=4.12 cfs 0.286 af
Reach CB8: EX-CB8	Inflow=24.05 cfs 1.671 af Outflow=24.05 cfs 1.671 af
Reach CB9: EX CB-9	Inflow=6.49 cfs 0.499 af Outflow=6.49 cfs 0.499 af
Reach DP-1: French Rodney Blvd 14" Outfall	Inflow=14.90 cfs 1.074 af Outflow=14.90 cfs 1.074 af
Reach DP-2: PORTLANDSTREET DRAINAGE	Inflow=49.10 cfs 3.513 af Outflow=49.10 cfs 3.513 af

Total Runoff Area = 8.690 ac Runoff Volume = 4.587 af Average Runoff Depth = 6.33"
36.09% Pervious = 3.136 ac 63.91% Impervious = 5.554 ac

14850_Existing-Drainage-Areas

NOAA 24-hr C NOAA 100-yr Rainfall=7.59"

Prepared by {enter your company name here}

Printed 4/6/2022

HydroCAD® 10.10-7a s/n 00546 © 2021 HydroCAD Software Solutions LLC

Page 34

Summary for Subcatchment 1B: CB-1B (mix)

Runoff = 5.61 cfs @ 12.13 hrs, Volume= 0.398 af, Depth= 6.28"
Routed to Reach CB1 : EX CB-1

Runoff by SCS TR-20 method, UH=SCS, Weighted-CN, Time Span= 0.00-72.00 hrs, dt= 0.05 hrs
NOAA 24-hr C NOAA 100-yr Rainfall=7.59"

Area (sf)	CN	Description
20,636	83	1/4 acre lots, 38% imp, HSG C
12,461	98	Paved parking, HSG C
33,097	89	Weighted Average
12,794		38.66% Pervious Area
20,303		61.34% Impervious Area

Tc (min)	Length (feet)	Slope (ft/ft)	Velocity (ft/sec)	Capacity (cfs)	Description
6.0					Direct Entry, residential & parking areas

Subcatchment 1B: CB-1B (mix)

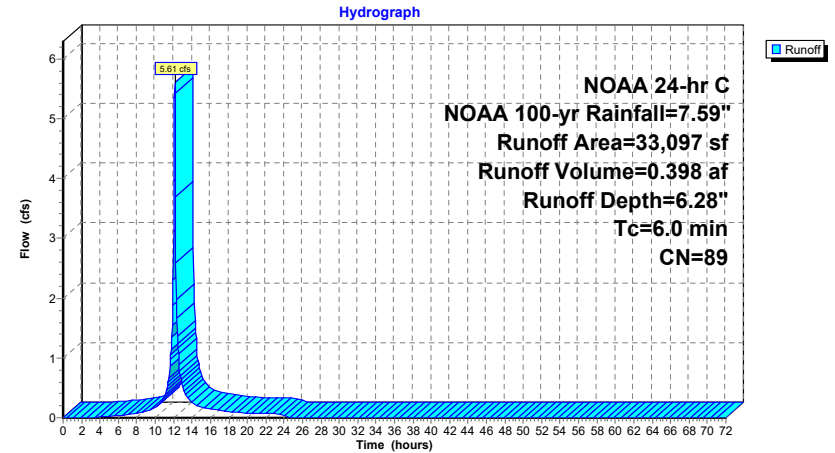

14850_Existing-Drainage-Areas

NOAA 24-hr C NOAA 100-yr Rainfall=7.59"

Prepared by {enter your company name here}

Printed 4/6/2022

HydroCAD® 10.10-7a s/n 00546 © 2021 HydroCAD Software Solutions LLC

Page 35

Summary for Subcatchment 2: CB-2 (mix)

Runoff = 3.91 cfs @ 12.13 hrs, Volume= 0.282 af, Depth= 6.52"
Routed to Reach CB2 : EX-CB2

Runoff by SCS TR-20 method, UH=SCS, Weighted-CN, Time Span= 0.00-72.00 hrs, dt= 0.05 hrs
NOAA 24-hr C NOAA 100-yr Rainfall=7.59"

Area (sf)	CN	Description
10,533	83	1/4 acre lots, 38% imp, HSG C
12,095	98	Paved parking, HSG C
22,628	91	Weighted Average
6,530		28.86% Pervious Area
16,098		71.14% Impervious Area

Tc (min)	Length (feet)	Slope (ft/ft)	Velocity (ft/sec)	Capacity (cfs)	Description
6.0					Direct Entry, residential & parking areas

Subcatchment 2: CB-2 (mix)

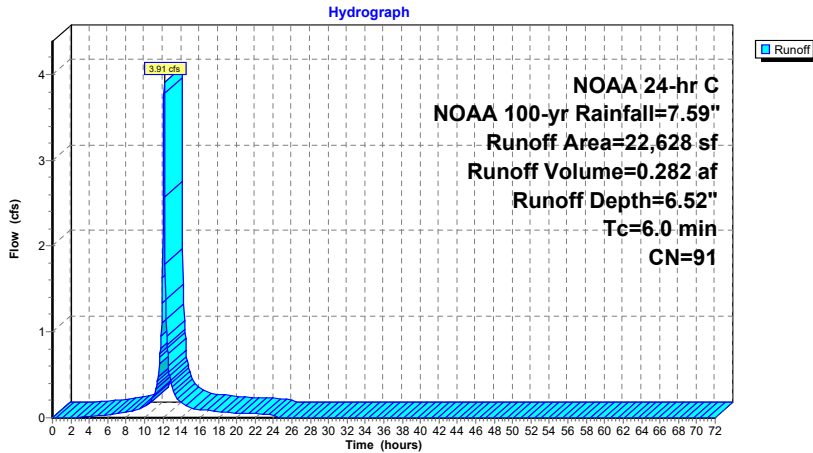

14850_Existing-Drainage-Areas

NOAA 24-hr C NOAA 100-yr Rainfall=7.59"

Prepared by {enter your company name here}

Printed 4/6/2022

HydroCAD® 10.10-7a s/n 00546 © 2021 HydroCAD Software Solutions LLC

Page 36

Summary for Subcatchment 3A: CB-3A (parking)

Runoff = 1.40 cfs @ 12.13 hrs, Volume= 0.109 af, Depth= 7.35"
Routed to Reach CB3 : EX-CB3

Runoff by SCS TR-20 method, UH=SCS, Weighted-CN, Time Span= 0.00-72.00 hrs, dt= 0.05 hrs
NOAA 24-hr C NOAA 100-yr Rainfall=7.59"

Area (sf)	CN	Description
7,758	98	Paved parking, HSG C
7,758		100.00% Impervious Area

Tc (min)	Length (feet)	Slope (ft/ft)	Velocity (ft/sec)	Capacity (cfs)	Description
6.0					Direct Entry, residential & parking areas

Subcatchment 3A: CB-3A (parking)

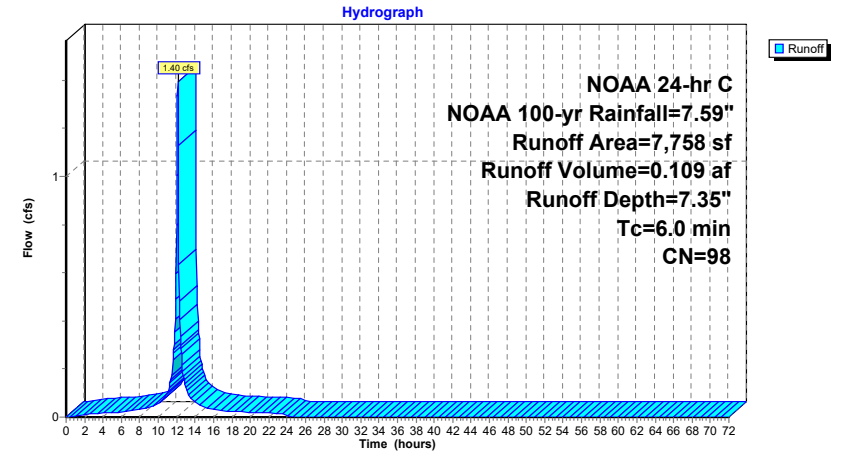

14850_Existing-Drainage-Areas

NOAA 24-hr C NOAA 100-yr Rainfall=7.59"

Prepared by {enter your company name here}

Printed 4/6/2022

HydroCAD® 10.10-7a s/n 00546 © 2021 HydroCAD Software Solutions LLC

Page 37

Summary for Subcatchment 3B: CB-3B (parking)

Runoff = 0.69 cfs @ 12.13 hrs, Volume= 0.053 af, Depth= 7.35"
Routed to Reach CB3 : EX-CB3

Runoff by SCS TR-20 method, UH=SCS, Weighted-CN, Time Span= 0.00-72.00 hrs, dt= 0.05 hrs
NOAA 24-hr C NOAA 100-yr Rainfall=7.59"

Area (sf)	CN	Description
3,797	98	Paved parking, HSG C
3,797		100.00% Impervious Area

Tc (min)	Length (feet)	Slope (ft/ft)	Velocity (ft/sec)	Capacity (cfs)	Description
6.0					Direct Entry, residential & parking areas

Subcatchment 3B: CB-3B (parking)

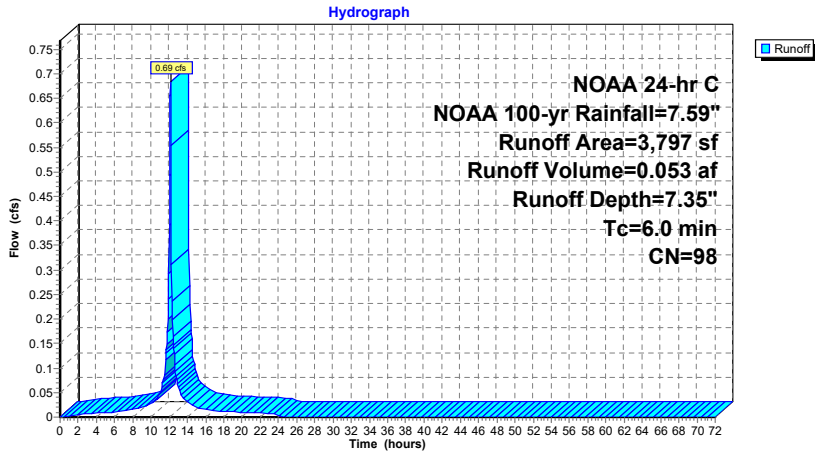

14850_Existing-Drainage-Areas

NOAA 24-hr C NOAA 100-yr Rainfall=7.59"

Prepared by {enter your company name here}

Printed 4/6/2022

HydroCAD® 10.10-7a s/n 00546 © 2021 HydroCAD Software Solutions LLC

Page 38

Summary for Subcatchment 5B: CB-5B (mix)

Runoff = 3.85 cfs @ 12.13 hrs, Volume= 0.271 af, Depth= 6.17"
Routed to Reach CB5 : EX-CB5

Runoff by SCS TR-20 method, UH=SCS, Weighted-CN, Time Span= 0.00-72.00 hrs, dt= 0.05 hrs
NOAA 24-hr C NOAA 100-yr Rainfall=7.59"

Area (sf)	CN	Description
15,743	83	1/4 acre lots, 38% imp, HSG C
7,231	98	Paved parking, HSG C
22,974	88	Weighted Average
9,761		42.49% Pervious Area
13,213		57.51% Impervious Area

Tc (min)	Length (feet)	Slope (ft/ft)	Velocity (ft/sec)	Capacity (cfs)	Description
6.0					Direct Entry, residential & parking areas

Subcatchment 5B: CB-5B (mix)

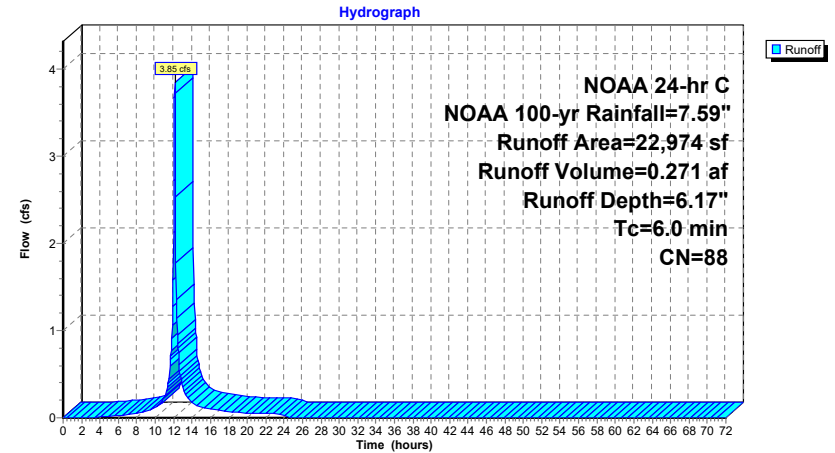

14850_Existing-Drainage-Areas

NOAA 24-hr C NOAA 100-yr Rainfall=7.59"

Prepared by {enter your company name here}

Printed 4/6/2022

HydroCAD® 10.10-7a s/n 00546 © 2021 HydroCAD Software Solutions LLC

Page 39

Summary for Subcatchment 6: CB-6 (mix)

Runoff = 6.18 cfs @ 12.13 hrs, Volume= 0.470 af, Depth= 7.11"
Routed to Reach CB6 : EX-CB6

Runoff by SCS TR-20 method, UH=SCS, Weighted-CN, Time Span= 0.00-72.00 hrs, dt= 0.05 hrs
NOAA 24-hr C NOAA 100-yr Rainfall=7.59"

Area (sf)	CN	Description
3,898	83	1/4 acre lots, 38% imp, HSG C
30,626	98	Paved parking, HSG C
34,524	96	Weighted Average
2,417		7.00% Pervious Area
32,107		93.00% Impervious Area

Tc (min)	Length (feet)	Slope (ft/ft)	Velocity (ft/sec)	Capacity (cfs)	Description
6.0					Direct Entry, residential & parking areas

Subcatchment 6: CB-6 (mix)

Hydrograph

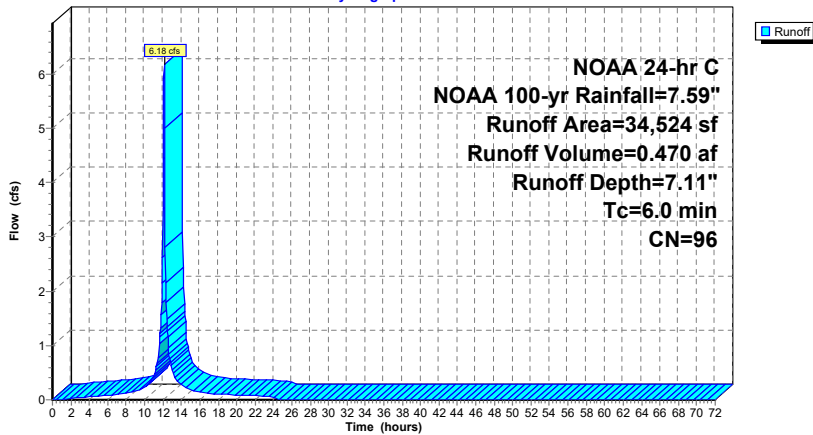

14850_Existing-Drainage-Areas

NOAA 24-hr C NOAA 100-yr Rainfall=7.59"

Prepared by {enter your company name here}

Printed 4/6/2022

HydroCAD® 10.10-7a s/n 00546 © 2021 HydroCAD Software Solutions LLC

Page 40

Summary for Subcatchment 8B: CB-8B (mix)

Runoff = 4.73 cfs @ 12.13 hrs, Volume= 0.330 af, Depth= 6.05"
Routed to Reach CB8 : EX-CB8

Runoff by SCS TR-20 method, UH=SCS, Weighted-CN, Time Span= 0.00-72.00 hrs, dt= 0.05 hrs
NOAA 24-hr C NOAA 100-yr Rainfall=7.59"

Area (sf)	CN	Description
20,925	83	1/4 acre lots, 38% imp, HSG C
7,603	98	Paved parking, HSG C
28,528	87	Weighted Average
12,974		45.48% Pervious Area
15,555		54.52% Impervious Area

Tc (min)	Length (feet)	Slope (ft/ft)	Velocity (ft/sec)	Capacity (cfs)	Description
6.0					Direct Entry, residential & parking areas

Subcatchment 8B: CB-8B (mix)

Hydrograph

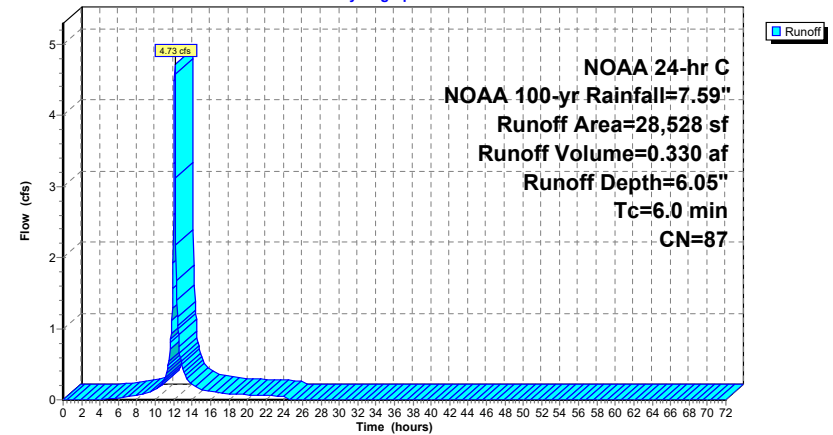

14850_Existing-Drainage-Areas

NOAA 24-hr C NOAA 100-yr Rainfall=7.59"

Prepared by {enter your company name here}

Printed 4/6/2022

HydroCAD® 10.10-7a s/n 00546 © 2021 HydroCAD Software Solutions LLC

Page 41

Summary for Subcatchment 9: CB-9 (mix)

Runoff = 6.49 cfs @ 12.13 hrs, Volume= 0.499 af, Depth= 7.23"
 Routed to Reach CB9 : EX CB-9

Runoff by SCS TR-20 method, UH=SCS, Weighted-CN, Time Span= 0.00-72.00 hrs, dt= 0.05 hrs
 NOAA 24-hr C NOAA 100-yr Rainfall=7.59"

Area (sf)	CN	Description
3,474	83	1/4 acre lots, 38% imp, HSG C
32,630	98	Paved parking, HSG C
36,104	97	Weighted Average
2,154		5.97% Pervious Area
33,950		94.03% Impervious Area

Tc (min)	Length (feet)	Slope (ft/ft)	Velocity (ft/sec)	Capacity (cfs)	Description
6.0					Direct Entry, residential & parking areas

Subcatchment 9: CB-9 (mix)

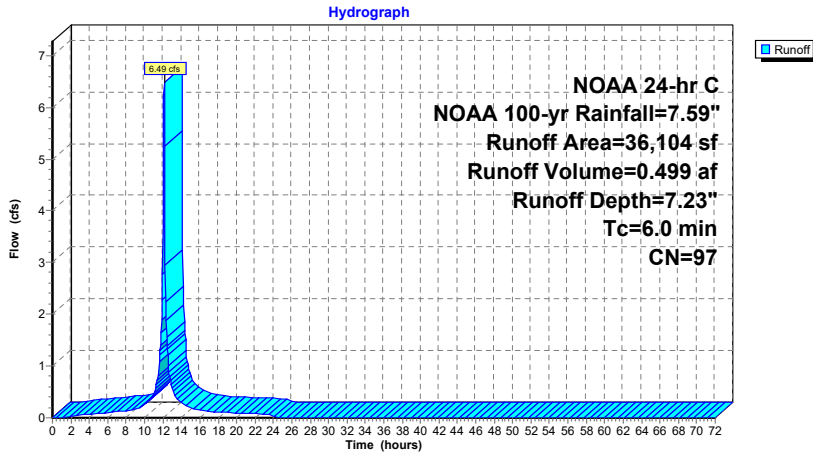

14850_Existing-Drainage-Areas

NOAA 24-hr C NOAA 100-yr Rainfall=7.59"

Prepared by {enter your company name here}

Printed 4/6/2022

HydroCAD® 10.10-7a s/n 00546 © 2021 HydroCAD Software Solutions LLC

Page 42

Summary for Subcatchment 10: CB-10 (parking)

Runoff = 1.17 cfs @ 12.13 hrs, Volume= 0.091 af, Depth= 7.35"
 Routed to Reach CB10 : EX-CB10

Runoff by SCS TR-20 method, UH=SCS, Weighted-CN, Time Span= 0.00-72.00 hrs, dt= 0.05 hrs
 NOAA 24-hr C NOAA 100-yr Rainfall=7.59"

Area (sf)	CN	Description
6,492	98	Paved parking, HSG C
6,492		100.00% Impervious Area

Tc (min)	Length (feet)	Slope (ft/ft)	Velocity (ft/sec)	Capacity (cfs)	Description
6.0					Direct Entry, residential & parking areas

Subcatchment 10: CB-10 (parking)

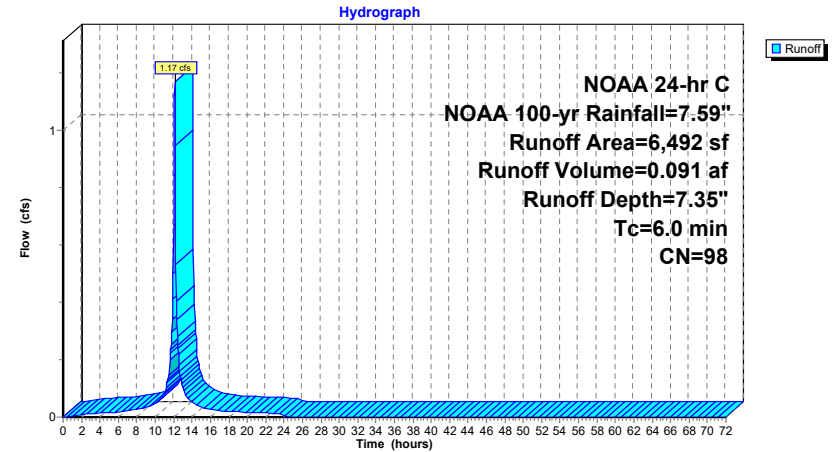

14850_Existing-Drainage-Areas

NOAA 24-hr C NOAA 100-yr Rainfall=7.59"

Prepared by {enter your company name here}

Printed 4/6/2022

HydroCAD® 10.10-7a s/n 00546 © 2021 HydroCAD Software Solutions LLC

Page 43

Summary for Subcatchment CB-1: New CB South (Seymour Street)

Runoff = 3.28 cfs @ 12.13 hrs, Volume= 0.231 af, Depth= 6.17"
Routed to Reach CB4 : EX-CB4

Runoff by SCS TR-20 method, UH=SCS, Weighted-CN, Time Span= 0.00-72.00 hrs, dt= 0.05 hrs
NOAA 24-hr C NOAA 100-yr Rainfall=7.59"

Area (sf)	CN	Description
13,211	83	1/4 acre lots, 38% imp, HSG C
* 6,371	98	Roadway
19,582	88	Weighted Average
8,191		41.83% Pervious Area
11,391		58.17% Impervious Area

Tc (min)	Length (feet)	Slope (ft/ft)	Velocity (ft/sec)	Capacity (cfs)	Description
0.6	50	0.0300	1.45		Sheet Flow, A-B Smooth surfaces n= 0.011 P2= 3.40"
2.4	462	0.0249	3.20		Shallow Concentrated Flow, Paved Paved Kv= 20.3 fps
3.0					Direct Entry, Direct entry to 6
6.0	512	Total			

Subcatchment CB-1: New CB South (Seymour Street)

Hydrograph

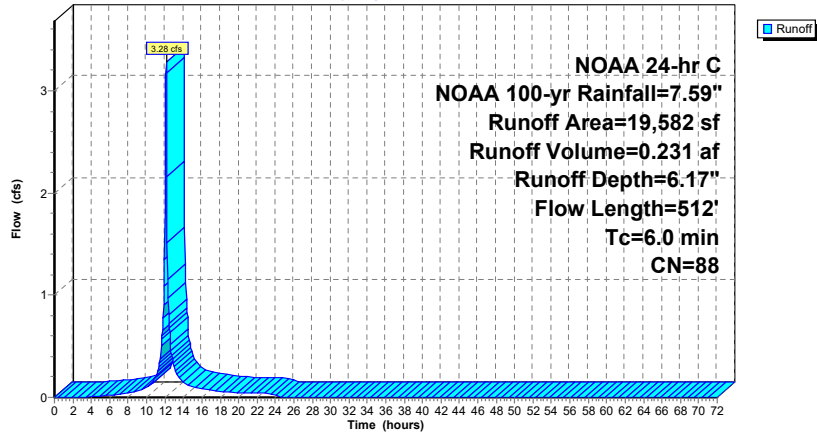

14850_Existing-Drainage-Areas

NOAA 24-hr C NOAA 100-yr Rainfall=7.59"

Prepared by {enter your company name here}

Printed 4/6/2022

HydroCAD® 10.10-7a s/n 00546 © 2021 HydroCAD Software Solutions LLC

Page 44

Summary for Subcatchment CB-3: NEW CB SOUTH- HUDSON ST

Runoff = 4.12 cfs @ 12.13 hrs, Volume= 0.286 af, Depth= 5.93"
Routed to Reach CB7 : EX-CB7

Runoff by SCS TR-20 method, UH=SCS, Weighted-CN, Time Span= 0.00-72.00 hrs, dt= 0.05 hrs
NOAA 24-hr C NOAA 100-yr Rainfall=7.59"

Area (sf)	CN	Description
19,562	83	1/4 acre lots, 38% imp, HSG C
* 5,621	98	Roadway
25,183	86	Weighted Average
12,128		48.16% Pervious Area
13,055		51.84% Impervious Area

Tc (min)	Length (feet)	Slope (ft/ft)	Velocity (ft/sec)	Capacity (cfs)	Description
0.5	50	0.0444	1.70		Sheet Flow, A-B (sheet flow) Smooth surfaces n= 0.011 P2= 3.40"
3.0	585	0.0256	3.25		Shallow Concentrated Flow, B-C Paved Kv= 20.3 fps
2.5					Direct Entry, direct entry to 6
6.0	635	Total			

Subcatchment CB-3: NEW CB SOUTH- HUDSON ST

Hydrograph

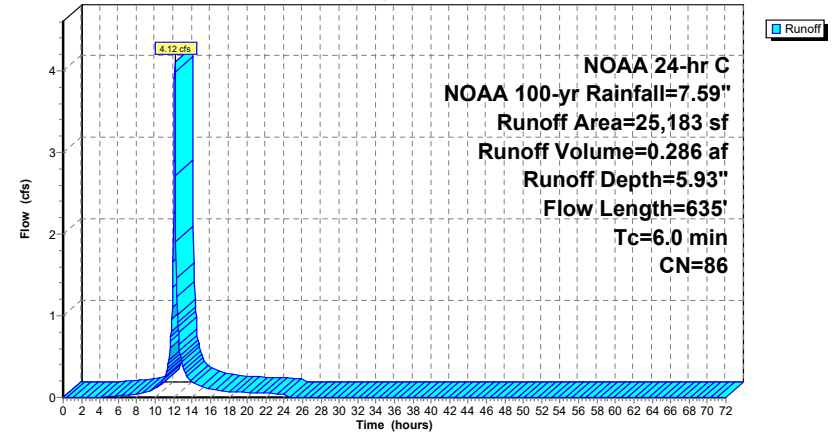

14850_Existing-Drainage-Areas

NOAA 24-hr C NOAA 100-yr Rainfall=7.59"

Prepared by {enter your company name here}

Printed 4/6/2022

HydroCAD® 10.10-7a s/n 00546 © 2021 HydroCAD Software Solutions LLC

Page 45

Summary for Subcatchment CB-4: NEW CB NOTH - HUDSON STREET

Runoff = 19.32 cfs @ 12.13 hrs, Volume= 1.341 af, Depth= 5.93"
Routed to Reach CB8 : EX-CB8

Runoff by SCS TR-20 method, UH=SCS, Weighted-CN, Time Span= 0.00-72.00 hrs, dt= 0.05 hrs
NOAA 24-hr C NOAA 100-yr Rainfall=7.59"

Area (sf)	CN	Description
96,716	83	1/4 acre lots, 38% imp, HSG C
* 21,410	98	Roadway
118,126	86	Weighted Average
59,964		50.76% Pervious Area
58,162		49.24% Impervious Area

Tc (min)	Length (feet)	Slope (ft/ft)	Velocity (ft/sec)	Capacity (cfs)	Description
0.5	50	0.0500	1.78		Sheet Flow, A-B (sheet flow) Smooth surfaces n= 0.011 P2= 3.40"
4.0	772	0.0245	3.18		Shallow Concentrated Flow, B-C (shallow concentrated) Paved Kv= 20.3 fps
1.5					Direct Entry, direct entry to 6
6.0	822	Total			

Subcatchment CB-4: NEW CB NOTH - HUDSON STREET

Hydrograph

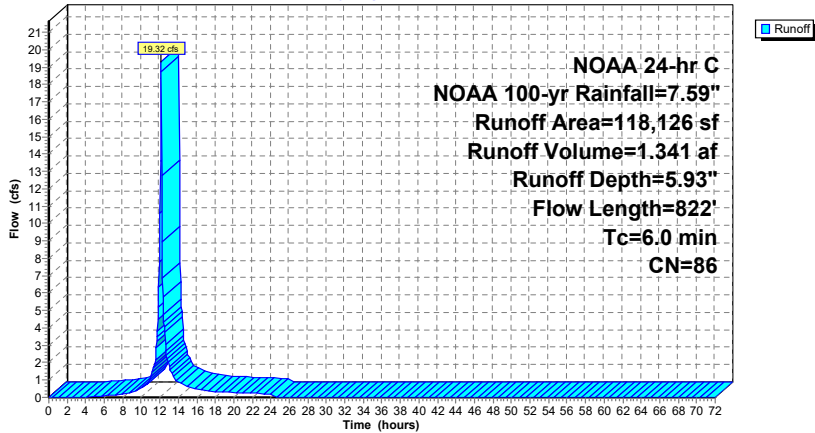

14850_Existing-Drainage-Areas

NOAA 24-hr C NOAA 100-yr Rainfall=7.59"

Prepared by {enter your company name here}

Printed 4/6/2022

HydroCAD® 10.10-7a s/n 00546 © 2021 HydroCAD Software Solutions LLC

Page 46

Summary for Subcatchment CB-5: NEW CB - PORTLAND ST SOUTH

Runoff = 3.23 cfs @ 12.13 hrs, Volume= 0.224 af, Depth= 5.93"
Routed to Reach CB11 : EX-CB11

Runoff by SCS TR-20 method, UH=SCS, Weighted-CN, Time Span= 0.00-72.00 hrs, dt= 0.05 hrs
NOAA 24-hr C NOAA 100-yr Rainfall=7.59"

Area (sf)	CN	Description
15,657	83	1/4 acre lots, 38% imp, HSG C
* 4,086	98	Roadway
19,743	86	Weighted Average
9,707		49.17% Pervious Area
10,036		50.83% Impervious Area

Tc (min)	Length (feet)	Slope (ft/ft)	Velocity (ft/sec)	Capacity (cfs)	Description
0.5	50	0.0500	1.78		Sheet Flow, A-B (sheet flow) Smooth surfaces n= 0.011 P2= 3.40"
2.3	524	0.0346	3.78		Shallow Concentrated Flow, B-C (shallow conc.) Paved Kv= 20.3 fps
3.2					Direct Entry, direct to 6
6.0	574	Total			

Subcatchment CB-5: NEW CB - PORTLAND ST SOUTH

Hydrograph

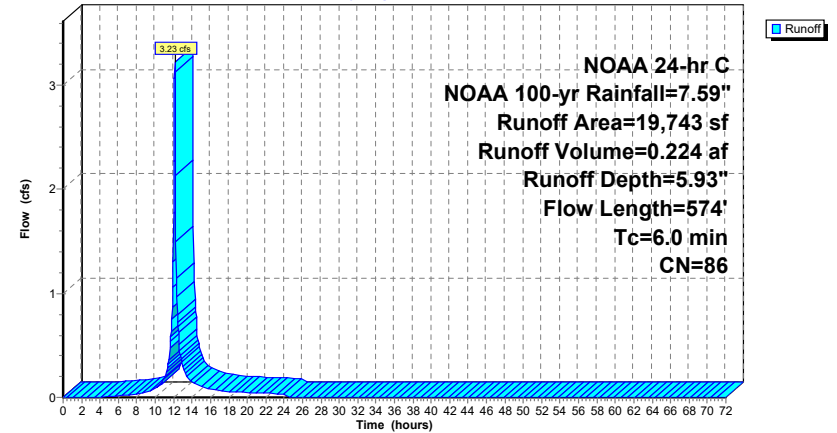

14850_Existing-Drainage-Areas

NOAA 24-hr C NOAA 100-yr Rainfall=7.59"

Prepared by {enter your company name here}

Printed 4/6/2022

HydroCAD® 10.10-7a s/n 00546 © 2021 HydroCAD Software Solutions LLC

Page 47

Summary for Reach CB1: EX CB-1

[40] Hint: Not Described (Outflow=Inflow)

Inflow Area = 0.760 ac, 61.34% Impervious, Inflow Depth = 6.28" for NOAA 100-yr event
Inflow = 5.61 cfs @ 12.13 hrs, Volume= 0.398 af
Outflow = 5.61 cfs @ 12.13 hrs, Volume= 0.398 af, Atten= 0%, Lag= 0.0 min
Routed to Reach DP-1 : French Rodney Blvd 14" Outfall

Routing by Stor-Ind+Trans method, Time Span= 0.00-72.00 hrs, dt= 0.05 hrs

Reach CB1: EX CB-1

Hydrograph

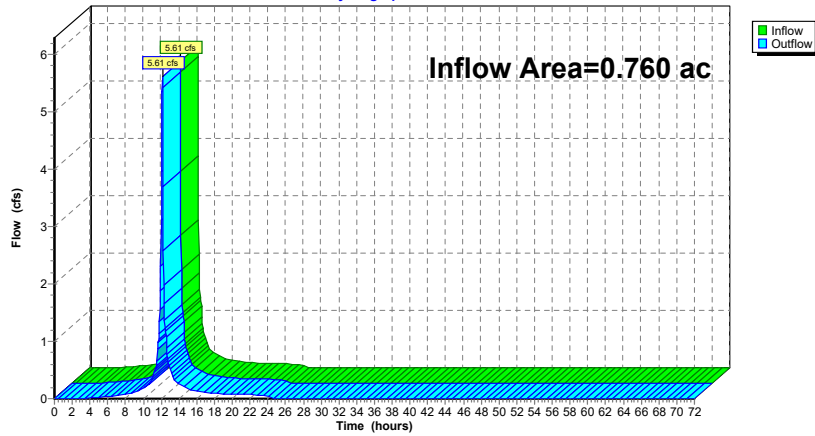

14850_Existing-Drainage-Areas

NOAA 24-hr C NOAA 100-yr Rainfall=7.59"

Prepared by {enter your company name here}

Printed 4/6/2022

HydroCAD® 10.10-7a s/n 00546 © 2021 HydroCAD Software Solutions LLC

Page 48

Summary for Reach CB10: EX-CB10

[40] Hint: Not Described (Outflow=Inflow)

Inflow Area = 0.149 ac, 100.00% Impervious, Inflow Depth = 7.35" for NOAA 100-yr event
Inflow = 1.17 cfs @ 12.13 hrs, Volume= 0.091 af
Outflow = 1.17 cfs @ 12.13 hrs, Volume= 0.091 af, Atten= 0%, Lag= 0.0 min
Routed to Reach DP-2 : PORTLAND STREET DRAINAGE

Routing by Stor-Ind+Trans method, Time Span= 0.00-72.00 hrs, dt= 0.05 hrs

Reach CB10: EX-CB10

Hydrograph

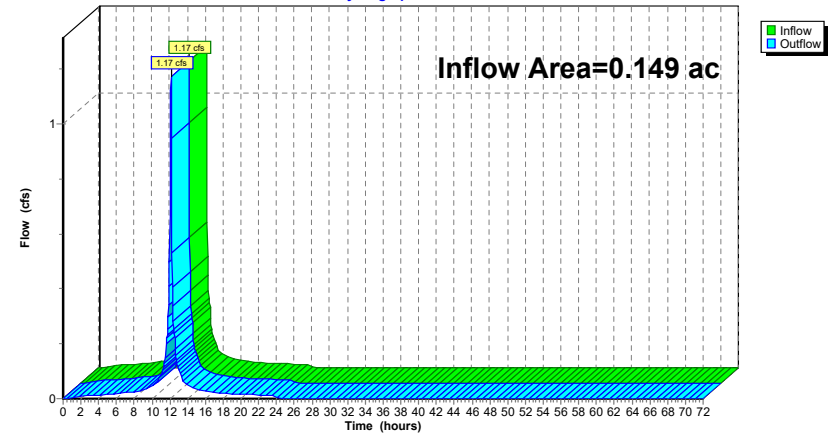

14850_Existing-Drainage-Areas

NOAA 24-hr C NOAA 100-yr Rainfall=7.59"

Prepared by {enter your company name here}

Printed 4/6/2022

HydroCAD® 10.10-7a s/n 00546 © 2021 HydroCAD Software Solutions LLC

Page 49

Summary for Reach CB11: EX-CB11

[40] Hint: Not Described (Outflow=Inflow)

Inflow Area = 0.453 ac, 50.83% Impervious, Inflow Depth = 5.93" for NOAA 100-yr event
Inflow = 3.23 cfs @ 12.13 hrs, Volume= 0.224 af
Outflow = 3.23 cfs @ 12.13 hrs, Volume= 0.224 af, Atten= 0%, Lag= 0.0 min
Routed to Reach DP-2 : PORTLAND STREET DRAINAGE

Routing by Stor-Ind+Trans method, Time Span= 0.00-72.00 hrs, dt= 0.05 hrs

Reach CB11: EX-CB11

Hydrograph

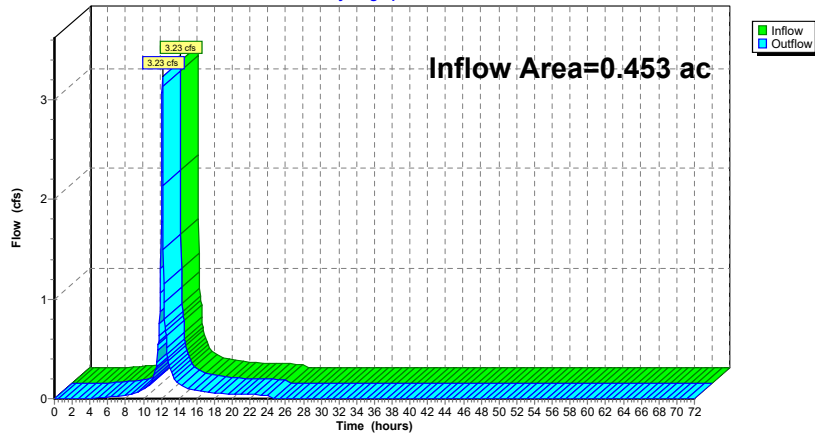

14850_Existing-Drainage-Areas

NOAA 24-hr C NOAA 100-yr Rainfall=7.59"

Prepared by {enter your company name here}

Printed 4/6/2022

HydroCAD® 10.10-7a s/n 00546 © 2021 HydroCAD Software Solutions LLC

Page 50

Summary for Reach CB2: EX-CB2

[40] Hint: Not Described (Outflow=Inflow)

Inflow Area = 0.519 ac, 71.14% Impervious, Inflow Depth = 6.52" for NOAA 100-yr event
Inflow = 3.91 cfs @ 12.13 hrs, Volume= 0.282 af
Outflow = 3.91 cfs @ 12.13 hrs, Volume= 0.282 af, Atten= 0%, Lag= 0.0 min
Routed to Reach DP-1 : French Rodney Blvd 14" Outfall

Routing by Stor-Ind+Trans method, Time Span= 0.00-72.00 hrs, dt= 0.05 hrs

Reach CB2: EX-CB2

Hydrograph

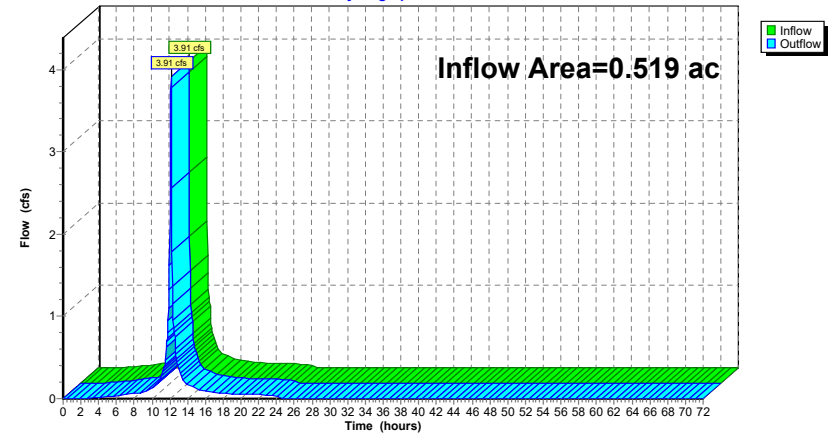

14850_Existing-Drainage-Areas

NOAA 24-hr C NOAA 100-yr Rainfall=7.59"

Prepared by {enter your company name here}

Printed 4/6/2022

HydroCAD® 10.10-7a s/n 00546 © 2021 HydroCAD Software Solutions LLC

Page 51

Summary for Reach CB3: EX-CB3

[40] Hint: Not Described (Outflow=Inflow)

Inflow Area = 0.265 ac, 100.00% Impervious, Inflow Depth = 7.35" for NOAA 100-yr event
Inflow = 2.08 cfs @ 12.13 hrs, Volume= 0.162 af
Outflow = 2.08 cfs @ 12.13 hrs, Volume= 0.162 af, Atten= 0%, Lag= 0.0 min
Routed to Reach DP-1 : French Rodney Blvd 14" Outfall

Routing by Stor-Ind+Trans method, Time Span= 0.00-72.00 hrs, dt= 0.05 hrs

Reach CB3: EX-CB3

Hydrograph

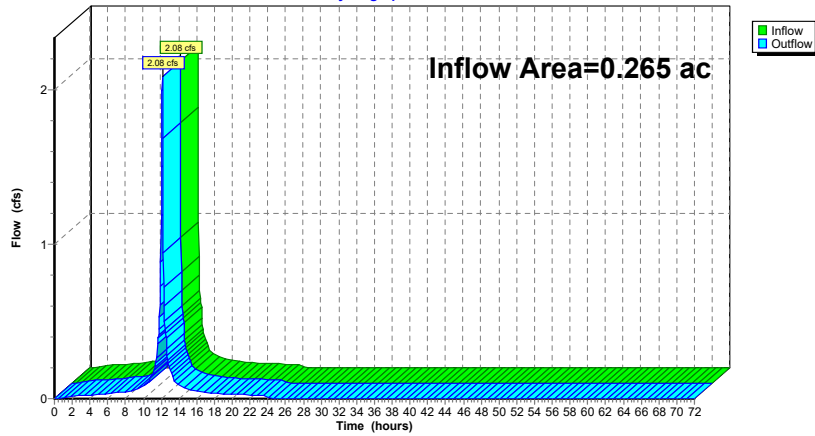

14850_Existing-Drainage-Areas

NOAA 24-hr C NOAA 100-yr Rainfall=7.59"

Prepared by {enter your company name here}

Printed 4/6/2022

HydroCAD® 10.10-7a s/n 00546 © 2021 HydroCAD Software Solutions LLC

Page 52

Summary for Reach CB4: EX-CB4

[40] Hint: Not Described (Outflow=Inflow)

Inflow Area = 0.450 ac, 58.17% Impervious, Inflow Depth = 6.17" for NOAA 100-yr event
Inflow = 3.28 cfs @ 12.13 hrs, Volume= 0.231 af
Outflow = 3.28 cfs @ 12.13 hrs, Volume= 0.231 af, Atten= 0%, Lag= 0.0 min
Routed to Reach DP-1 : French Rodney Blvd 14" Outfall

Routing by Stor-Ind+Trans method, Time Span= 0.00-72.00 hrs, dt= 0.05 hrs

Reach CB4: EX-CB4

Hydrograph

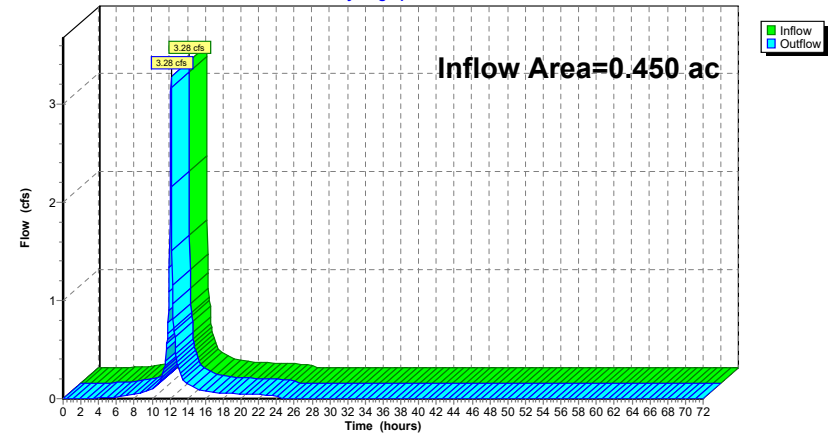

14850_Existing-Drainage-Areas

NOAA 24-hr C NOAA 100-yr Rainfall=7.59"

Prepared by {enter your company name here}

Printed 4/6/2022

HydroCAD® 10.10-7a s/n 00546 © 2021 HydroCAD Software Solutions LLC

Page 53

Summary for Reach CB5: EX-CB5

[40] Hint: Not Described (Outflow=Inflow)

Inflow Area = 0.527 ac, 57.51% Impervious, Inflow Depth = 6.17" for NOAA 100-yr event
Inflow = 3.85 cfs @ 12.13 hrs, Volume= 0.271 af
Outflow = 3.85 cfs @ 12.13 hrs, Volume= 0.271 af, Atten= 0%, Lag= 0.0 min
Routed to Reach DP-2 : PORTLAND STREET DRAINAGE

Routing by Stor-Ind+Trans method, Time Span= 0.00-72.00 hrs, dt= 0.05 hrs

Reach CB5: EX-CB5

Hydrograph

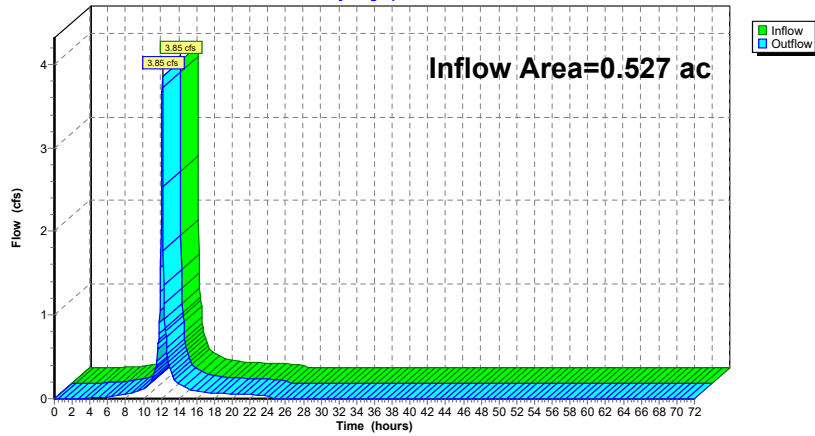

14850_Existing-Drainage-Areas

NOAA 24-hr C NOAA 100-yr Rainfall=7.59"

Prepared by {enter your company name here}

Printed 4/6/2022

HydroCAD® 10.10-7a s/n 00546 © 2021 HydroCAD Software Solutions LLC

Page 54

Summary for Reach CB6: EX-CB6

[40] Hint: Not Described (Outflow=Inflow)

Inflow Area = 0.793 ac, 93.00% Impervious, Inflow Depth = 7.11" for NOAA 100-yr event
Inflow = 6.18 cfs @ 12.13 hrs, Volume= 0.470 af
Outflow = 6.18 cfs @ 12.13 hrs, Volume= 0.470 af, Atten= 0%, Lag= 0.0 min
Routed to Reach DP-2 : PORTLAND STREET DRAINAGE

Routing by Stor-Ind+Trans method, Time Span= 0.00-72.00 hrs, dt= 0.05 hrs

Reach CB6: EX-CB6

Hydrograph

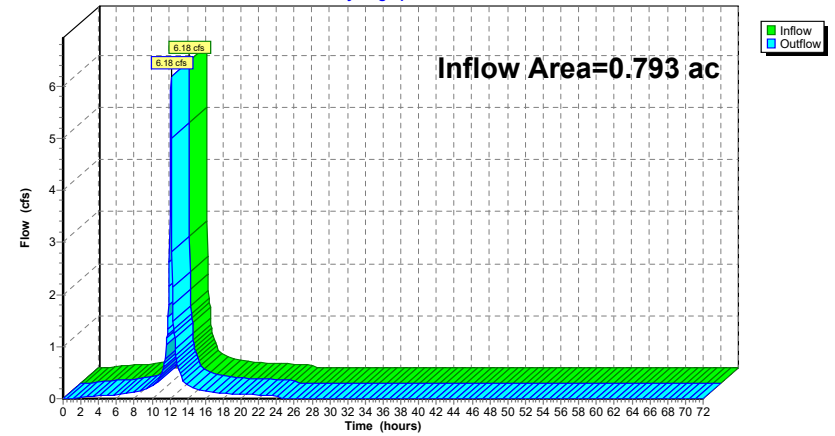

14850_Existing-Drainage-Areas

NOAA 24-hr C NOAA 100-yr Rainfall=7.59"

Prepared by {enter your company name here}

Printed 4/6/2022

HydroCAD® 10.10-7a s/n 00546 © 2021 HydroCAD Software Solutions LLC

Page 55

Summary for Reach CB7: EX-CB7

[40] Hint: Not Described (Outflow=Inflow)

Inflow Area = 0.578 ac, 51.84% Impervious, Inflow Depth = 5.93" for NOAA 100-yr event
Inflow = 4.12 cfs @ 12.13 hrs, Volume= 0.286 af
Outflow = 4.12 cfs @ 12.13 hrs, Volume= 0.286 af, Atten= 0%, Lag= 0.0 min
Routed to Reach DP-2 : PORTLAND STREET DRAINAGE

Routing by Stor-Ind+Trans method, Time Span= 0.00-72.00 hrs, dt= 0.05 hrs

Reach CB7: EX-CB7

Hydrograph

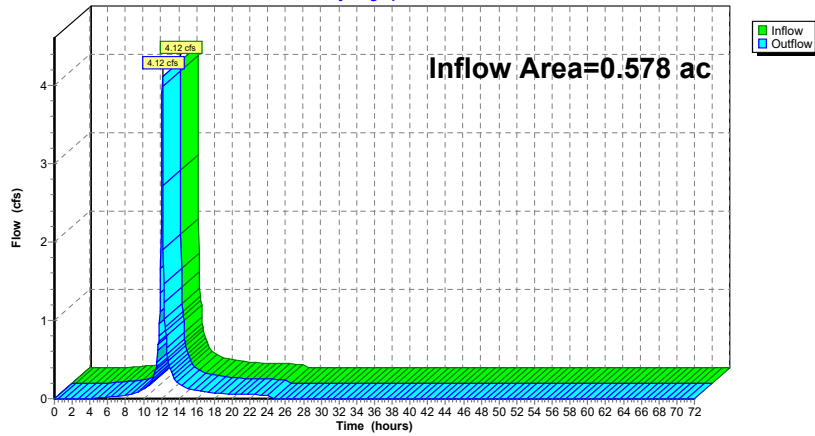

14850_Existing-Drainage-Areas

NOAA 24-hr C NOAA 100-yr Rainfall=7.59"

Prepared by {enter your company name here}

Printed 4/6/2022

HydroCAD® 10.10-7a s/n 00546 © 2021 HydroCAD Software Solutions LLC

Page 56

Summary for Reach CB8: EX-CB8

[40] Hint: Not Described (Outflow=Inflow)

Inflow Area = 3.367 ac, 50.27% Impervious, Inflow Depth = 5.96" for NOAA 100-yr event
Inflow = 24.05 cfs @ 12.13 hrs, Volume= 1.671 af
Outflow = 24.05 cfs @ 12.13 hrs, Volume= 1.671 af, Atten= 0%, Lag= 0.0 min
Routed to Reach DP-2 : PORTLAND STREET DRAINAGE

Routing by Stor-Ind+Trans method, Time Span= 0.00-72.00 hrs, dt= 0.05 hrs

Reach CB8: EX-CB8

Hydrograph

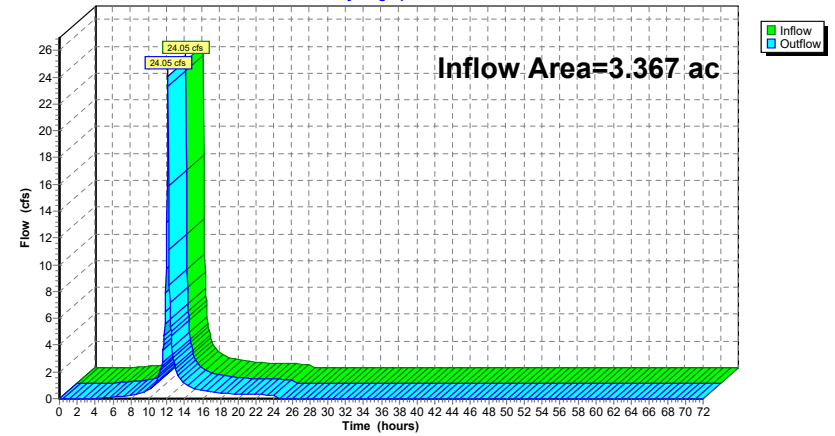

14850_Existing-Drainage-Areas

NOAA 24-hr C NOAA 100-yr Rainfall=7.59"

Prepared by {enter your company name here}

Printed 4/6/2022

HydroCAD® 10.10-7a s/n 00546 © 2021 HydroCAD Software Solutions LLC

Page 57

Summary for Reach CB9: EX CB-9

[40] Hint: Not Described (Outflow=Inflow)

Inflow Area = 0.829 ac, 94.03% Impervious, Inflow Depth = 7.23" for NOAA 100-yr event
Inflow = 6.49 cfs @ 12.13 hrs, Volume= 0.499 af
Outflow = 6.49 cfs @ 12.13 hrs, Volume= 0.499 af, Atten= 0%, Lag= 0.0 min
Routed to Reach DP-2 : PORTLAND STREET DRAINAGE

Routing by Stor-Ind+Trans method, Time Span= 0.00-72.00 hrs, dt= 0.05 hrs

Reach CB9: EX CB-9

Hydrograph

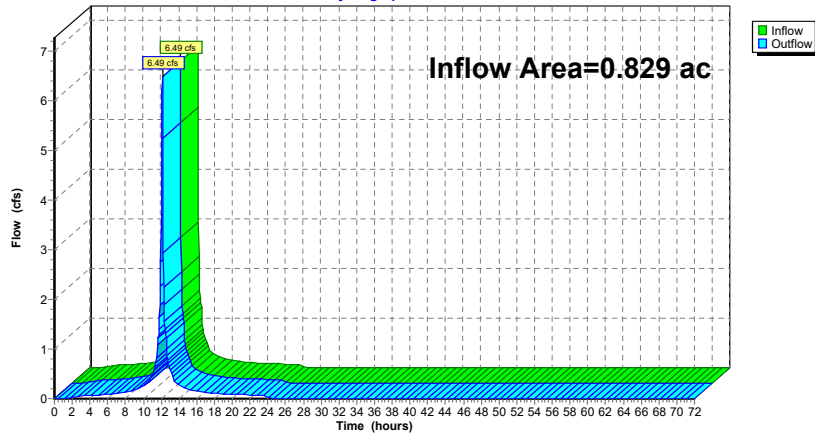

14850_Existing-Drainage-Areas

NOAA 24-hr C NOAA 100-yr Rainfall=7.59"

Prepared by {enter your company name here}

Printed 4/6/2022

HydroCAD® 10.10-7a s/n 00546 © 2021 HydroCAD Software Solutions LLC

Page 58

Summary for Reach DP-1: French Rodney Blvd 14" Outfall

[40] Hint: Not Described (Outflow=Inflow)

Inflow Area = 1.994 ac, 68.32% Impervious, Inflow Depth = 6.46" for NOAA 100-yr event
Inflow = 14.90 cfs @ 12.13 hrs, Volume= 1.074 af
Outflow = 14.90 cfs @ 12.13 hrs, Volume= 1.074 af, Atten= 0%, Lag= 0.0 min

Routing by Stor-Ind+Trans method, Time Span= 0.00-72.00 hrs, dt= 0.05 hrs

Reach DP-1: French Rodney Blvd 14" Outfall

Hydrograph

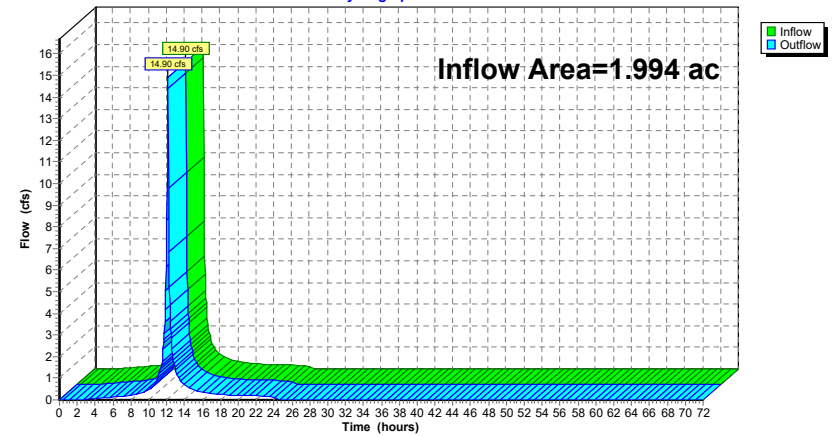

14850_Existing-Drainage-Areas

NOAA 24-hr C NOAA 100-yr Rainfall=7.59"

Prepared by {enter your company name here}

Printed 4/6/2022

HydroCAD® 10.10-7a s/n 00546 © 2021 HydroCAD Software Solutions LLC

Page 59

Summary for Reach DP-2: PORTLAND STREET DRAINAGE

[40] Hint: Not Described (Outflow=Inflow)

Inflow Area = 6.696 ac, 62.59% Impervious, Inflow Depth = 6.30" for NOAA 100-yr event
 Inflow = 49.10 cfs @ 12.13 hrs, Volume= 3.513 af
 Outflow = 49.10 cfs @ 12.13 hrs, Volume= 3.513 af, Atten= 0%, Lag= 0.0 min

Routing by Stor-Ind+Trans method, Time Span= 0.00-72.00 hrs, dt= 0.05 hrs

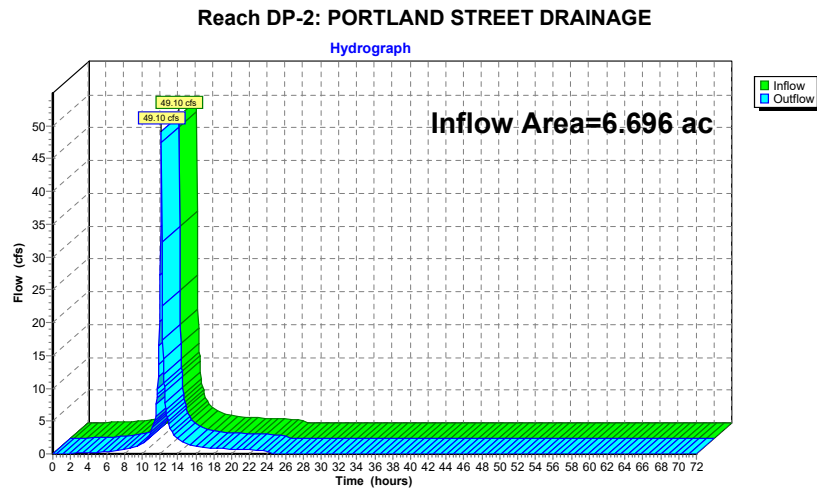

14850_Existing-Drainage-Areas

NOAA 24-hr C NOAA 2-yr Rainfall=3.40"

Prepared by {enter your company name here}

Printed 4/6/2022

HydroCAD® 10.10-7a s/n 00546 © 2021 HydroCAD Software Solutions LLC

Page 60

Time span=0.00-72.00 hrs, dt=0.05 hrs, 1441 points

Runoff by SCS TR-20 method, UH=SCS, Weighted-CN

Reach routing by Stor-Ind+Trans method - Pond routing by Stor-Ind method

Subcatchment1B: CB-1B (mix)	Runoff Area=33,097 sf 61.34% Impervious Runoff Depth=2.26" Tc=6.0 min CN=89 Runoff=2.15 cfs 0.143 af
Subcatchment2: CB-2 (mix)	Runoff Area=22,628 sf 71.14% Impervious Runoff Depth=2.45" Tc=6.0 min CN=91 Runoff=1.56 cfs 0.106 af
Subcatchment3A: CB-3A (parking)	Runoff Area=7,758 sf 100.00% Impervious Runoff Depth=3.17" Tc=6.0 min CN=98 Runoff=0.62 cfs 0.047 af
Subcatchment3B: CB-3B (parking)	Runoff Area=3,797 sf 100.00% Impervious Runoff Depth=3.17" Tc=6.0 min CN=98 Runoff=0.30 cfs 0.023 af
Subcatchment5B: CB-5B (mix)	Runoff Area=22,974 sf 57.51% Impervious Runoff Depth=2.18" Tc=6.0 min CN=88 Runoff=1.44 cfs 0.096 af
Subcatchment6: CB-6 (mix)	Runoff Area=34,524 sf 93.00% Impervious Runoff Depth=2.95" Tc=6.0 min CN=96 Runoff=2.69 cfs 0.195 af
Subcatchment8B: CB-8B (mix)	Runoff Area=28,528 sf 54.52% Impervious Runoff Depth=2.09" Tc=6.0 min CN=87 Runoff=1.73 cfs 0.114 af
Subcatchment9: CB-9 (mix)	Runoff Area=36,104 sf 94.03% Impervious Runoff Depth=3.06" Tc=6.0 min CN=97 Runoff=2.86 cfs 0.211 af
Subcatchment10: CB-10 (parking)	Runoff Area=6,492 sf 100.00% Impervious Runoff Depth=3.17" Tc=6.0 min CN=98 Runoff=0.52 cfs 0.039 af
SubcatchmentCB-1: New CB South	Runoff Area=19,582 sf 58.17% Impervious Runoff Depth=2.18" Flow Length=512' Tc=6.0 min CN=88 Runoff=1.23 cfs 0.082 af
SubcatchmentCB-3: NEW CB SOUTH-	Runoff Area=25,183 sf 51.84% Impervious Runoff Depth=2.01" Flow Length=635' Tc=6.0 min CN=86 Runoff=1.47 cfs 0.097 af
SubcatchmentCB-4: NEW CB NOTH -	Runoff Area=118,126 sf 49.24% Impervious Runoff Depth=2.01" Flow Length=822' Tc=6.0 min CN=86 Runoff=6.90 cfs 0.454 af
SubcatchmentCB-5: NEW CB -	Runoff Area=19,743 sf 50.83% Impervious Runoff Depth=2.01" Flow Length=574' Tc=6.0 min CN=86 Runoff=1.15 cfs 0.076 af
Reach CB1: EX CB-1	Inflow=2.15 cfs 0.143 af Outflow=2.15 cfs 0.143 af
Reach CB10: EX-CB10	Inflow=0.52 cfs 0.039 af Outflow=0.52 cfs 0.039 af
Reach CB11: EX-CB11	Inflow=1.15 cfs 0.076 af Outflow=1.15 cfs 0.076 af

14850_Existing-Drainage-Areas

NOAA 24-hr C NOAA 2-yr Rainfall=3.40"

Prepared by {enter your company name here}

Printed 4/6/2022

HydroCAD® 10.10-7a s/n 00546 © 2021 HydroCAD Software Solutions LLC

Page 61

Reach CB2: EX-CB2	Inflow=1.56 cfs 0.106 af Outflow=1.56 cfs 0.106 af
Reach CB3: EX-CB3	Inflow=0.93 cfs 0.070 af Outflow=0.93 cfs 0.070 af
Reach CB4: EX-CB4	Inflow=1.23 cfs 0.082 af Outflow=1.23 cfs 0.082 af
Reach CB5: EX-CB5	Inflow=1.44 cfs 0.096 af Outflow=1.44 cfs 0.096 af
Reach CB6: EX-CB6	Inflow=2.69 cfs 0.195 af Outflow=2.69 cfs 0.195 af
Reach CB7: EX-CB7	Inflow=1.47 cfs 0.097 af Outflow=1.47 cfs 0.097 af
Reach CB8: EX-CB8	Inflow=8.63 cfs 0.568 af Outflow=8.63 cfs 0.568 af
Reach CB9: EX CB-9	Inflow=2.86 cfs 0.211 af Outflow=2.86 cfs 0.211 af
Reach DP-1: French Rodney Blvd 14" Outfall	Inflow=5.86 cfs 0.401 af Outflow=5.86 cfs 0.401 af
Reach DP-2: PORTLANDSTREET DRAINAGE	Inflow=18.76 cfs 1.282 af Outflow=18.76 cfs 1.282 af

Total Runoff Area = 8.690 ac Runoff Volume = 1.683 af Average Runoff Depth = 2.32"
36.09% Pervious = 3.136 ac 63.91% Impervious = 5.554 ac

14850_Existing-Drainage-Areas

NOAA 24-hr C NOAA 2-yr Rainfall=3.40"

Prepared by {enter your company name here}

Printed 4/6/2022

HydroCAD® 10.10-7a s/n 00546 © 2021 HydroCAD Software Solutions LLC

Page 62

Summary for Subcatchment 1B: CB-1B (mix)

Runoff = 2.15 cfs @ 12.13 hrs, Volume= 0.143 af, Depth= 2.26"
Routed to Reach CB1 : EX CB-1

Runoff by SCS TR-20 method, UH=SCS, Weighted-CN, Time Span= 0.00-72.00 hrs, dt= 0.05 hrs
NOAA 24-hr C NOAA 2-yr Rainfall=3.40"

Area (sf)	CN	Description
20,636	83	1/4 acre lots, 38% imp, HSG C
12,461	98	Paved parking, HSG C
33,097	89	Weighted Average
12,794		38.66% Pervious Area
20,303		61.34% Impervious Area

Tc (min)	Length (feet)	Slope (ft/ft)	Velocity (ft/sec)	Capacity (cfs)	Description
6.0					Direct Entry, residential & parking areas

Subcatchment 1B: CB-1B (mix)

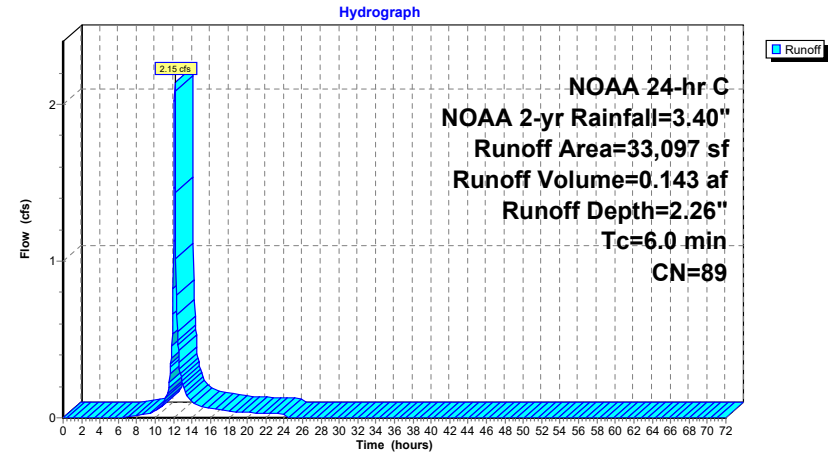

14850_Existing-Drainage-Areas

NOAA 24-hr C NOAA 2-yr Rainfall=3.40"

Prepared by {enter your company name here}

Printed 4/6/2022

HydroCAD® 10.10-7a s/n 00546 © 2021 HydroCAD Software Solutions LLC

Page 63

Summary for Subcatchment 2: CB-2 (mix)

Runoff = 1.56 cfs @ 12.13 hrs, Volume= 0.106 af, Depth= 2.45"
Routed to Reach CB2 : EX-CB2

Runoff by SCS TR-20 method, UH=SCS, Weighted-CN, Time Span= 0.00-72.00 hrs, dt= 0.05 hrs
NOAA 24-hr C NOAA 2-yr Rainfall=3.40"

Area (sf)	CN	Description
10,533	83	1/4 acre lots, 38% imp, HSG C
12,095	98	Paved parking, HSG C
22,628	91	Weighted Average
6,530		28.86% Pervious Area
16,098		71.14% Impervious Area

Tc (min)	Length (feet)	Slope (ft/ft)	Velocity (ft/sec)	Capacity (cfs)	Description
6.0					Direct Entry, residential & parking areas

Subcatchment 2: CB-2 (mix)

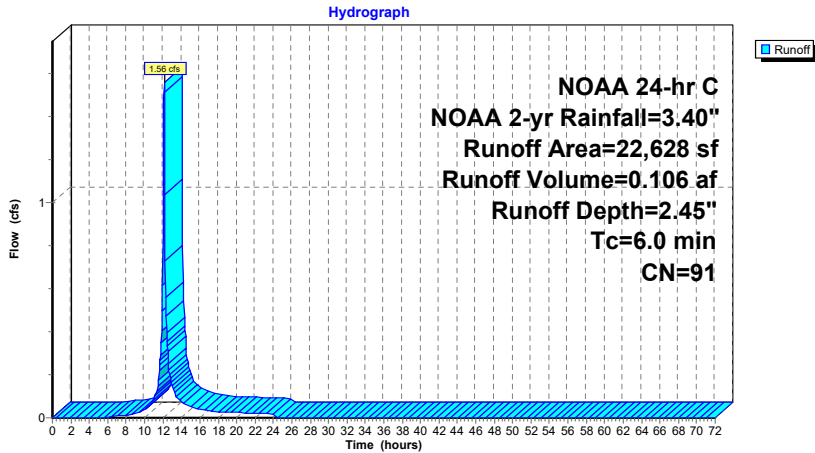

14850_Existing-Drainage-Areas

NOAA 24-hr C NOAA 2-yr Rainfall=3.40"

Prepared by {enter your company name here}

Printed 4/6/2022

HydroCAD® 10.10-7a s/n 00546 © 2021 HydroCAD Software Solutions LLC

Page 64

Summary for Subcatchment 3A: CB-3A (parking)

Runoff = 0.62 cfs @ 12.13 hrs, Volume= 0.047 af, Depth= 3.17"
Routed to Reach CB3 : EX-CB3

Runoff by SCS TR-20 method, UH=SCS, Weighted-CN, Time Span= 0.00-72.00 hrs, dt= 0.05 hrs
NOAA 24-hr C NOAA 2-yr Rainfall=3.40"

Area (sf)	CN	Description
7,758	98	Paved parking, HSG C
7,758		100.00% Impervious Area

Tc (min)	Length (feet)	Slope (ft/ft)	Velocity (ft/sec)	Capacity (cfs)	Description
6.0					Direct Entry, residential & parking areas

Subcatchment 3A: CB-3A (parking)

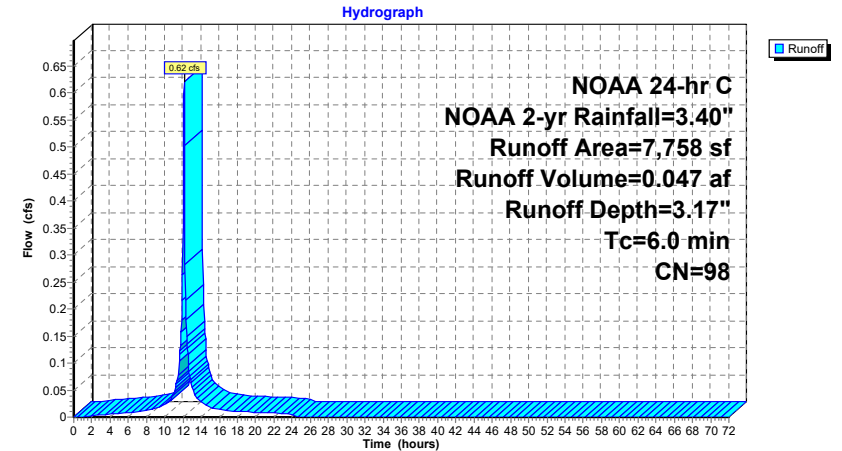

14850_Existing-Drainage-Areas

NOAA 24-hr C NOAA 2-yr Rainfall=3.40"

Prepared by {enter your company name here}

Printed 4/6/2022

HydroCAD® 10.10-7a s/n 00546 © 2021 HydroCAD Software Solutions LLC

Page 65

Summary for Subcatchment 3B: CB-3B (parking)

Runoff = 0.30 cfs @ 12.13 hrs, Volume= 0.023 af, Depth= 3.17"
Routed to Reach CB3 : EX-CB3

Runoff by SCS TR-20 method, UH=SCS, Weighted-CN, Time Span= 0.00-72.00 hrs, dt= 0.05 hrs
NOAA 24-hr C NOAA 2-yr Rainfall=3.40"

Area (sf)	CN	Description
3,797	98	Paved parking, HSG C
3,797		100.00% Impervious Area

Tc (min)	Length (feet)	Slope (ft/ft)	Velocity (ft/sec)	Capacity (cfs)	Description
6.0					Direct Entry, residential & parking areas

Subcatchment 3B: CB-3B (parking)

Hydrograph

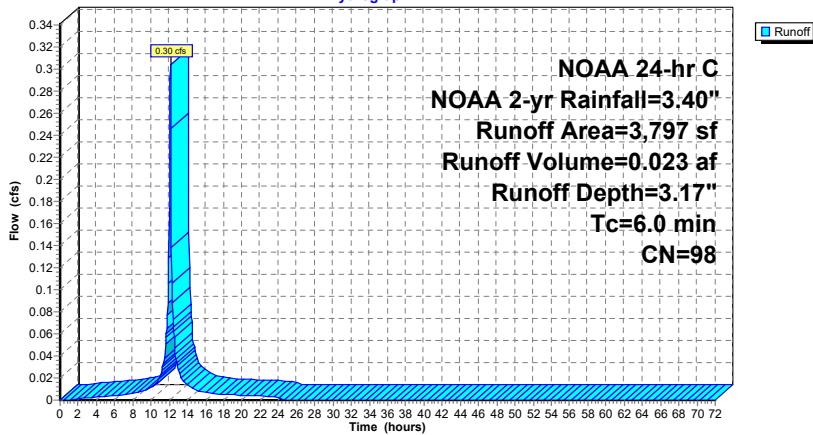

14850_Existing-Drainage-Areas

NOAA 24-hr C NOAA 2-yr Rainfall=3.40"

Prepared by {enter your company name here}

Printed 4/6/2022

HydroCAD® 10.10-7a s/n 00546 © 2021 HydroCAD Software Solutions LLC

Page 66

Summary for Subcatchment 5B: CB-5B (mix)

Runoff = 1.44 cfs @ 12.13 hrs, Volume= 0.096 af, Depth= 2.18"
Routed to Reach CB5 : EX-CB5

Runoff by SCS TR-20 method, UH=SCS, Weighted-CN, Time Span= 0.00-72.00 hrs, dt= 0.05 hrs
NOAA 24-hr C NOAA 2-yr Rainfall=3.40"

Area (sf)	CN	Description
15,743	83	1/4 acre lots, 38% imp, HSG C
7,231	98	Paved parking, HSG C
22,974	88	Weighted Average
9,761		42.49% Pervious Area
13,213		57.51% Impervious Area

Tc (min)	Length (feet)	Slope (ft/ft)	Velocity (ft/sec)	Capacity (cfs)	Description
6.0					Direct Entry, residential & parking areas

Subcatchment 5B: CB-5B (mix)

Hydrograph

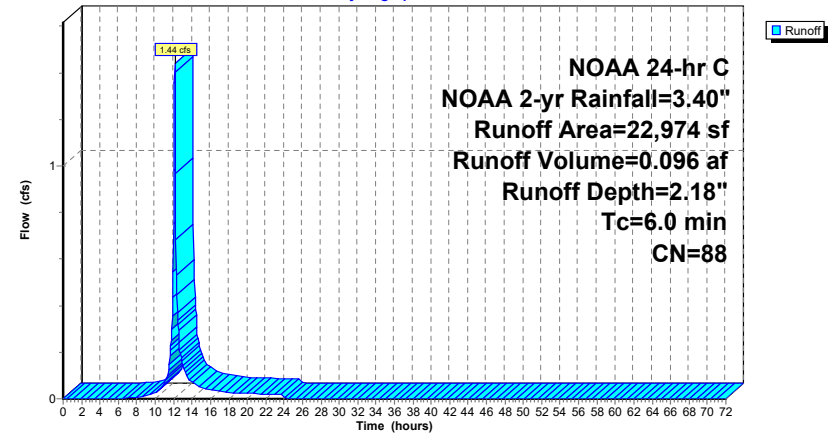

14850_Existing-Drainage-Areas

NOAA 24-hr C NOAA 2-yr Rainfall=3.40"

Prepared by {enter your company name here}

Printed 4/6/2022

HydroCAD® 10.10-7a s/n 00546 © 2021 HydroCAD Software Solutions LLC

Page 67

Summary for Subcatchment 6: CB-6 (mix)

Runoff = 2.69 cfs @ 12.13 hrs, Volume= 0.195 af, Depth= 2.95"
Routed to Reach CB6 : EX-CB6

Runoff by SCS TR-20 method, UH=SCS, Weighted-CN, Time Span= 0.00-72.00 hrs, dt= 0.05 hrs
NOAA 24-hr C NOAA 2-yr Rainfall=3.40"

Area (sf)	CN	Description
3,898	83	1/4 acre lots, 38% imp, HSG C
30,626	98	Paved parking, HSG C
34,524	96	Weighted Average
2,417		7.00% Pervious Area
32,107		93.00% Impervious Area

Tc (min)	Length (feet)	Slope (ft/ft)	Velocity (ft/sec)	Capacity (cfs)	Description
6.0					Direct Entry, residential & parking areas

Subcatchment 6: CB-6 (mix)

Hydrograph

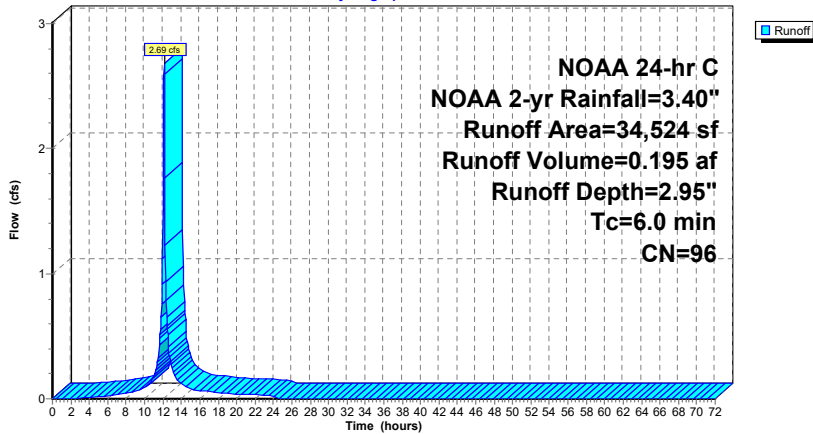

14850_Existing-Drainage-Areas

NOAA 24-hr C NOAA 2-yr Rainfall=3.40"

Prepared by {enter your company name here}

Printed 4/6/2022

HydroCAD® 10.10-7a s/n 00546 © 2021 HydroCAD Software Solutions LLC

Page 68

Summary for Subcatchment 8B: CB-8B (mix)

Runoff = 1.73 cfs @ 12.13 hrs, Volume= 0.114 af, Depth= 2.09"
Routed to Reach CB8 : EX-CB8

Runoff by SCS TR-20 method, UH=SCS, Weighted-CN, Time Span= 0.00-72.00 hrs, dt= 0.05 hrs
NOAA 24-hr C NOAA 2-yr Rainfall=3.40"

Area (sf)	CN	Description
20,925	83	1/4 acre lots, 38% imp, HSG C
7,603	98	Paved parking, HSG C
28,528	87	Weighted Average
12,974		45.48% Pervious Area
15,555		54.52% Impervious Area

Tc (min)	Length (feet)	Slope (ft/ft)	Velocity (ft/sec)	Capacity (cfs)	Description
6.0					Direct Entry, residential & parking areas

Subcatchment 8B: CB-8B (mix)

Hydrograph

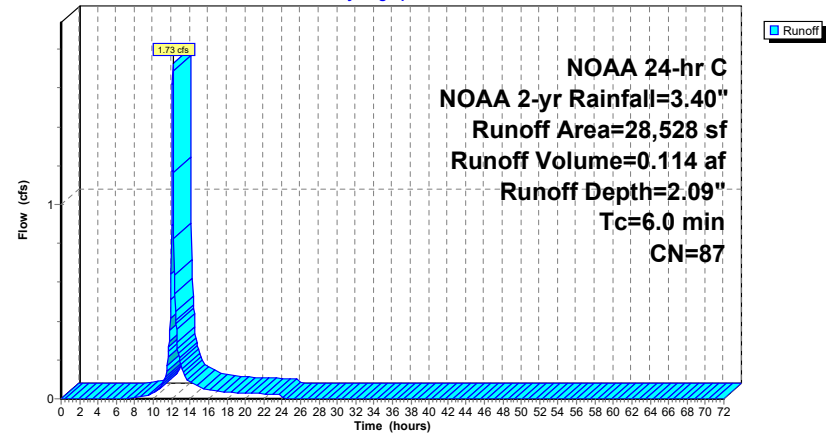

14850_Existing-Drainage-Areas

NOAA 24-hr C NOAA 2-yr Rainfall=3.40"

Prepared by {enter your company name here}

Printed 4/6/2022

HydroCAD® 10.10-7a s/n 00546 © 2021 HydroCAD Software Solutions LLC

Page 69

Summary for Subcatchment 9: CB-9 (mix)

Runoff = 2.86 cfs @ 12.13 hrs, Volume= 0.211 af, Depth= 3.06"
Routed to Reach CB9 : EX CB-9

Runoff by SCS TR-20 method, UH=SCS, Weighted-CN, Time Span= 0.00-72.00 hrs, dt= 0.05 hrs
NOAA 24-hr C NOAA 2-yr Rainfall=3.40"

Area (sf)	CN	Description
3,474	83	1/4 acre lots, 38% imp, HSG C
32,630	98	Paved parking, HSG C
36,104	97	Weighted Average
2,154		5.97% Pervious Area
33,950		94.03% Impervious Area

Tc (min)	Length (feet)	Slope (ft/ft)	Velocity (ft/sec)	Capacity (cfs)	Description
6.0					Direct Entry, residential & parking areas

Subcatchment 9: CB-9 (mix)

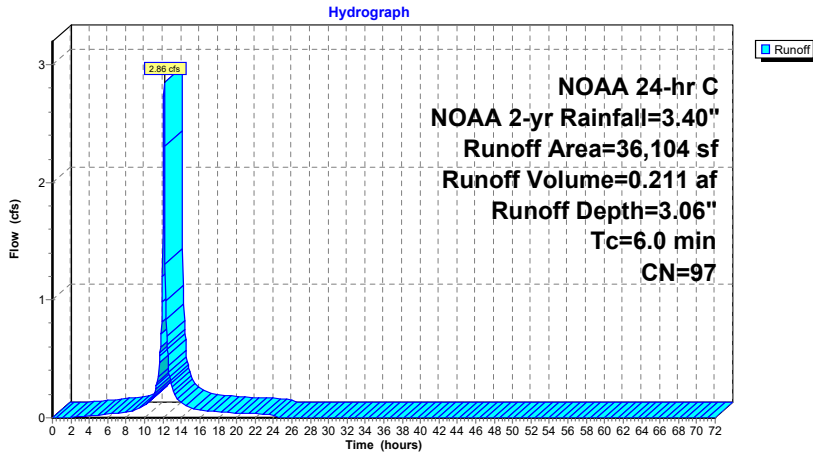

14850_Existing-Drainage-Areas

NOAA 24-hr C NOAA 2-yr Rainfall=3.40"

Prepared by {enter your company name here}

Printed 4/6/2022

HydroCAD® 10.10-7a s/n 00546 © 2021 HydroCAD Software Solutions LLC

Page 70

Summary for Subcatchment 10: CB-10 (parking)

Runoff = 0.52 cfs @ 12.13 hrs, Volume= 0.039 af, Depth= 3.17"
Routed to Reach CB10 : EX-CB10

Runoff by SCS TR-20 method, UH=SCS, Weighted-CN, Time Span= 0.00-72.00 hrs, dt= 0.05 hrs
NOAA 24-hr C NOAA 2-yr Rainfall=3.40"

Area (sf)	CN	Description
6,492	98	Paved parking, HSG C
6,492		100.00% Impervious Area

Tc (min)	Length (feet)	Slope (ft/ft)	Velocity (ft/sec)	Capacity (cfs)	Description
6.0					Direct Entry, residential & parking areas

Subcatchment 10: CB-10 (parking)

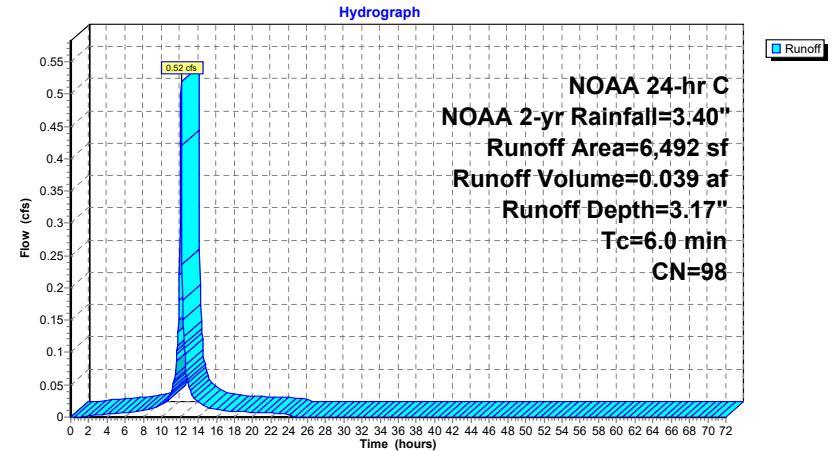

14850_Existing-Drainage-Areas

NOAA 24-hr C NOAA 2-yr Rainfall=3.40"

Prepared by {enter your company name here}

Printed 4/6/2022

HydroCAD® 10.10-7a s/n 00546 © 2021 HydroCAD Software Solutions LLC

Page 71

Summary for Subcatchment CB-1: New CB South (Seymour Street)

Runoff = 1.23 cfs @ 12.13 hrs, Volume= 0.082 af, Depth= 2.18"
Routed to Reach CB4 : EX-CB4

Runoff by SCS TR-20 method, UH=SCS, Weighted-CN, Time Span= 0.00-72.00 hrs, dt= 0.05 hrs
NOAA 24-hr C NOAA 2-yr Rainfall=3.40"

Area (sf)	CN	Description
13,211	83	1/4 acre lots, 38% imp, HSG C
* 6,371	98	Roadway
19,582	88	Weighted Average
8,191		41.83% Pervious Area
11,391		58.17% Impervious Area

Tc (min)	Length (feet)	Slope (ft/ft)	Velocity (ft/sec)	Capacity (cfs)	Description
0.6	50	0.0300	1.45		Sheet Flow, A-B Smooth surfaces n= 0.011 P2= 3.40"
2.4	462	0.0249	3.20		Shallow Concentrated Flow, Paved Paved Kv= 20.3 fps
3.0					Direct Entry, Direct entry to 6
6.0	512	Total			

Subcatchment CB-1: New CB South (Seymour Street)

Hydrograph

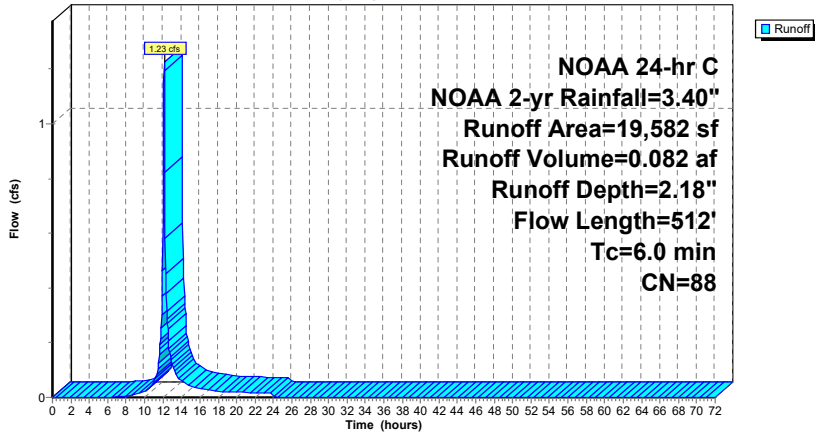

14850_Existing-Drainage-Areas

NOAA 24-hr C NOAA 2-yr Rainfall=3.40"

Prepared by {enter your company name here}

Printed 4/6/2022

HydroCAD® 10.10-7a s/n 00546 © 2021 HydroCAD Software Solutions LLC

Page 72

Summary for Subcatchment CB-3: NEW CB SOUTH- HUDSON ST

Runoff = 1.47 cfs @ 12.13 hrs, Volume= 0.097 af, Depth= 2.01"
Routed to Reach CB7 : EX-CB7

Runoff by SCS TR-20 method, UH=SCS, Weighted-CN, Time Span= 0.00-72.00 hrs, dt= 0.05 hrs
NOAA 24-hr C NOAA 2-yr Rainfall=3.40"

Area (sf)	CN	Description
19,562	83	1/4 acre lots, 38% imp, HSG C
* 5,621	98	Roadway
25,183	86	Weighted Average
12,128		48.16% Pervious Area
13,055		51.84% Impervious Area

Tc (min)	Length (feet)	Slope (ft/ft)	Velocity (ft/sec)	Capacity (cfs)	Description
0.5	50	0.0444	1.70		Sheet Flow, A-B (sheet flow) Smooth surfaces n= 0.011 P2= 3.40"
3.0	585	0.0256	3.25		Shallow Concentrated Flow, B-C Paved Kv= 20.3 fps
2.5					Direct Entry, direct entry to 6
6.0	635	Total			

Subcatchment CB-3: NEW CB SOUTH- HUDSON ST

Hydrograph

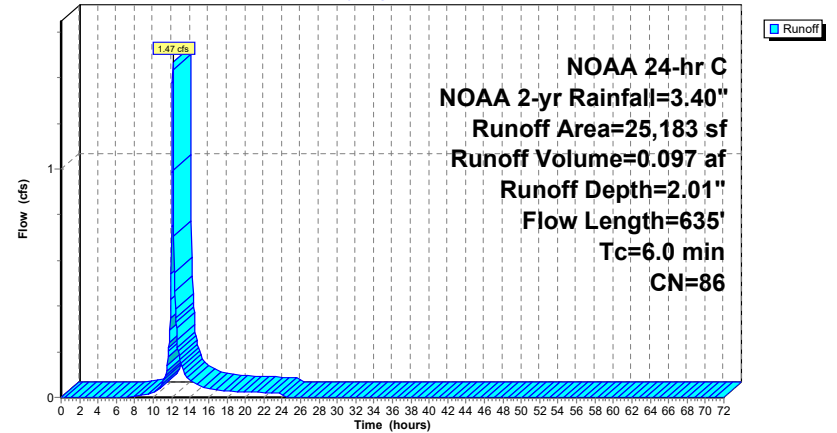

14850_Existing-Drainage-Areas

NOAA 24-hr C NOAA 2-yr Rainfall=3.40"

Prepared by {enter your company name here}

Printed 4/6/2022

HydroCAD® 10.10-7a s/n 00546 © 2021 HydroCAD Software Solutions LLC

Page 73

Summary for Subcatchment CB-4: NEW CB NOTH - HUDSON STREET

Runoff = 6.90 cfs @ 12.13 hrs, Volume= 0.454 af, Depth= 2.01"
Routed to Reach CB8 : EX-CB8

Runoff by SCS TR-20 method, UH=SCS, Weighted-CN, Time Span= 0.00-72.00 hrs, dt= 0.05 hrs
NOAA 24-hr C NOAA 2-yr Rainfall=3.40"

Area (sf)	CN	Description
96,716	83	1/4 acre lots, 38% imp, HSG C
* 21,410	98	Roadway
118,126	86	Weighted Average
59,964		50.76% Pervious Area
58,162		49.24% Impervious Area

Tc (min)	Length (feet)	Slope (ft/ft)	Velocity (ft/sec)	Capacity (cfs)	Description
0.5	50	0.0500	1.78		Sheet Flow, A-B (sheet flow) Smooth surfaces n= 0.011 P2= 3.40"
4.0	772	0.0245	3.18		Shallow Concentrated Flow, B-C (shallow concentrated) Paved Kv= 20.3 fps
1.5					Direct Entry, direct entry to 6
6.0	822	Total			

Subcatchment CB-4: NEW CB NOTH - HUDSON STREET

Hydrograph

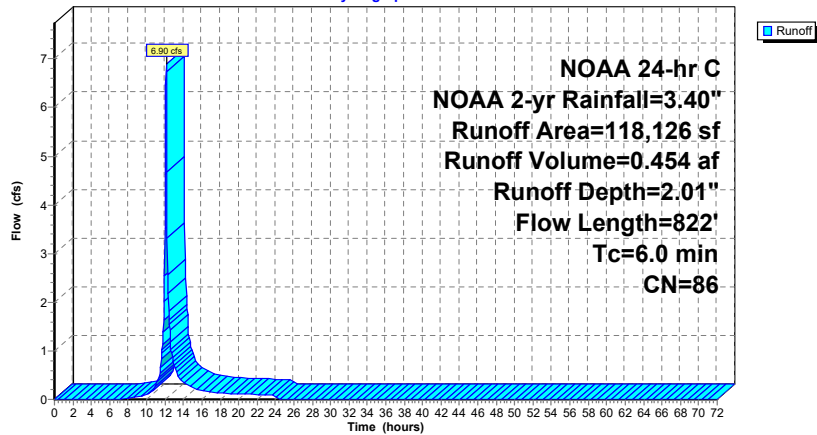

14850_Existing-Drainage-Areas

NOAA 24-hr C NOAA 2-yr Rainfall=3.40"

Prepared by {enter your company name here}

Printed 4/6/2022

HydroCAD® 10.10-7a s/n 00546 © 2021 HydroCAD Software Solutions LLC

Page 74

Summary for Subcatchment CB-5: NEW CB - PORTLAND ST SOUTH

Runoff = 1.15 cfs @ 12.13 hrs, Volume= 0.076 af, Depth= 2.01"
Routed to Reach CB11 : EX-CB11

Runoff by SCS TR-20 method, UH=SCS, Weighted-CN, Time Span= 0.00-72.00 hrs, dt= 0.05 hrs
NOAA 24-hr C NOAA 2-yr Rainfall=3.40"

Area (sf)	CN	Description
15,657	83	1/4 acre lots, 38% imp, HSG C
* 4,086	98	Roadway
19,743	86	Weighted Average
9,707		49.17% Pervious Area
10,036		50.83% Impervious Area

Tc (min)	Length (feet)	Slope (ft/ft)	Velocity (ft/sec)	Capacity (cfs)	Description
0.5	50	0.0500	1.78		Sheet Flow, A-B (sheet flow) Smooth surfaces n= 0.011 P2= 3.40"
2.3	524	0.0346	3.78		Shallow Concentrated Flow, B-C (shallow conc.) Paved Kv= 20.3 fps
3.2					Direct Entry, direct to 6
6.0	574	Total			

Subcatchment CB-5: NEW CB - PORTLAND ST SOUTH

Hydrograph

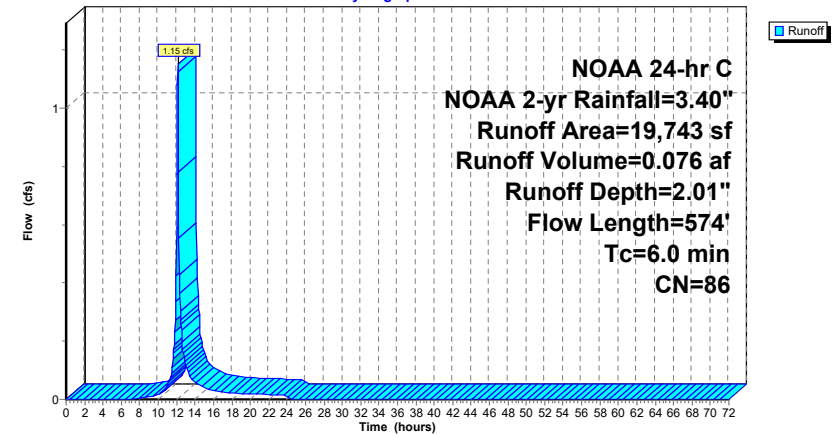

14850_Existing-Drainage-Areas

NOAA 24-hr C NOAA 2-yr Rainfall=3.40"

Prepared by {enter your company name here}

Printed 4/6/2022

HydroCAD® 10.10-7a s/n 00546 © 2021 HydroCAD Software Solutions LLC

Page 75

Summary for Reach CB1: EX CB-1

[40] Hint: Not Described (Outflow=Inflow)

Inflow Area = 0.760 ac, 61.34% Impervious, Inflow Depth = 2.26" for NOAA 2-yr event
 Inflow = 2.15 cfs @ 12.13 hrs, Volume= 0.143 af
 Outflow = 2.15 cfs @ 12.13 hrs, Volume= 0.143 af, Atten= 0%, Lag= 0.0 min
 Routed to Reach DP-1 : French Rodney Blvd 14" Outfall

Routing by Stor-Ind+Trans method, Time Span= 0.00-72.00 hrs, dt= 0.05 hrs

Reach CB1: EX CB-1

Hydrograph

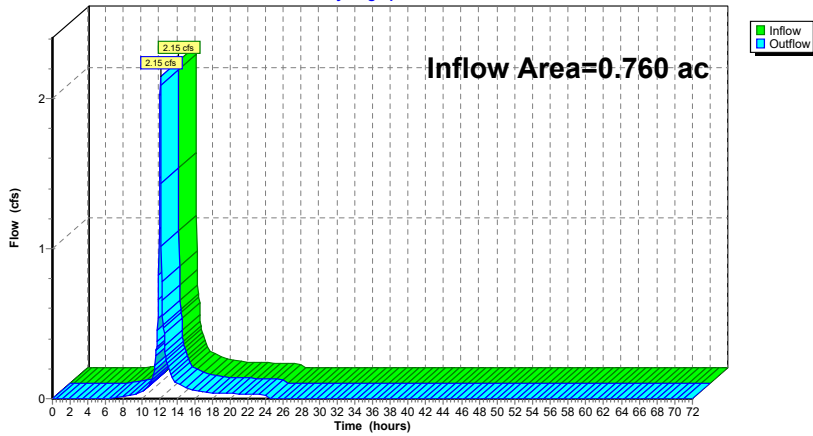

14850_Existing-Drainage-Areas

NOAA 24-hr C NOAA 2-yr Rainfall=3.40"

Prepared by {enter your company name here}

Printed 4/6/2022

HydroCAD® 10.10-7a s/n 00546 © 2021 HydroCAD Software Solutions LLC

Page 76

Summary for Reach CB10: EX-CB10

[40] Hint: Not Described (Outflow=Inflow)

Inflow Area = 0.149 ac, 100.00% Impervious, Inflow Depth = 3.17" for NOAA 2-yr event
 Inflow = 0.52 cfs @ 12.13 hrs, Volume= 0.039 af
 Outflow = 0.52 cfs @ 12.13 hrs, Volume= 0.039 af, Atten= 0%, Lag= 0.0 min
 Routed to Reach DP-2 : PORTLAND STREET DRAINAGE

Routing by Stor-Ind+Trans method, Time Span= 0.00-72.00 hrs, dt= 0.05 hrs

Reach CB10: EX-CB10

Hydrograph

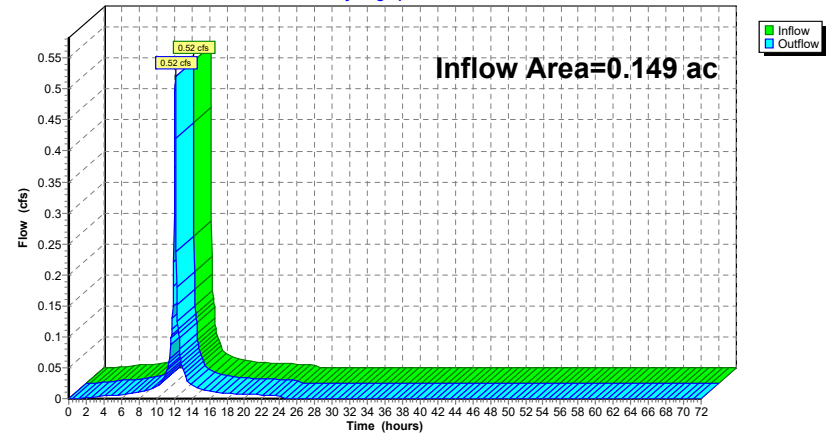

14850_Existing-Drainage-Areas

NOAA 24-hr C NOAA 2-yr Rainfall=3.40"

Prepared by {enter your company name here}

Printed 4/6/2022

HydroCAD® 10.10-7a s/n 00546 © 2021 HydroCAD Software Solutions LLC

Page 77

Summary for Reach CB11: EX-CB11

[40] Hint: Not Described (Outflow=Inflow)

Inflow Area = 0.453 ac, 50.83% Impervious, Inflow Depth = 2.01" for NOAA 2-yr event
Inflow = 1.15 cfs @ 12.13 hrs, Volume= 0.076 af
Outflow = 1.15 cfs @ 12.13 hrs, Volume= 0.076 af, Atten= 0%, Lag= 0.0 min
Routed to Reach DP-2 : PORTLAND STREET DRAINAGE

Routing by Stor-Ind+Trans method, Time Span= 0.00-72.00 hrs, dt= 0.05 hrs

Reach CB11: EX-CB11

Hydrograph

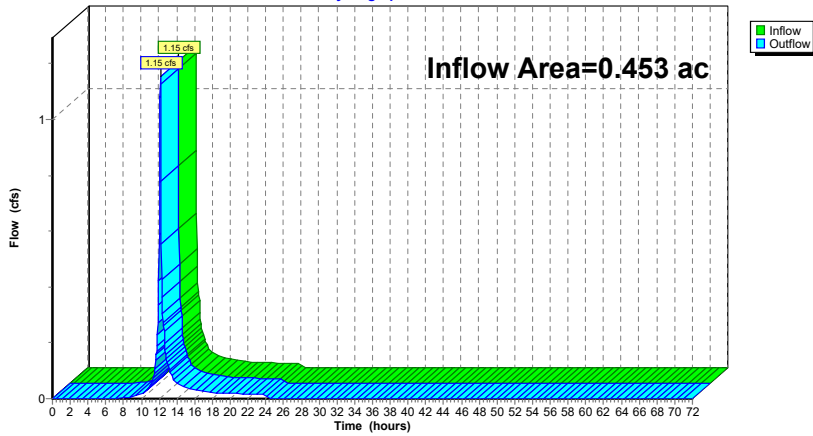

14850_Existing-Drainage-Areas

NOAA 24-hr C NOAA 2-yr Rainfall=3.40"

Prepared by {enter your company name here}

Printed 4/6/2022

HydroCAD® 10.10-7a s/n 00546 © 2021 HydroCAD Software Solutions LLC

Page 78

Summary for Reach CB2: EX-CB2

[40] Hint: Not Described (Outflow=Inflow)

Inflow Area = 0.519 ac, 71.14% Impervious, Inflow Depth = 2.45" for NOAA 2-yr event
Inflow = 1.56 cfs @ 12.13 hrs, Volume= 0.106 af
Outflow = 1.56 cfs @ 12.13 hrs, Volume= 0.106 af, Atten= 0%, Lag= 0.0 min
Routed to Reach DP-1 : French Rodney Blvd 14" Outfall

Routing by Stor-Ind+Trans method, Time Span= 0.00-72.00 hrs, dt= 0.05 hrs

Reach CB2: EX-CB2

Hydrograph

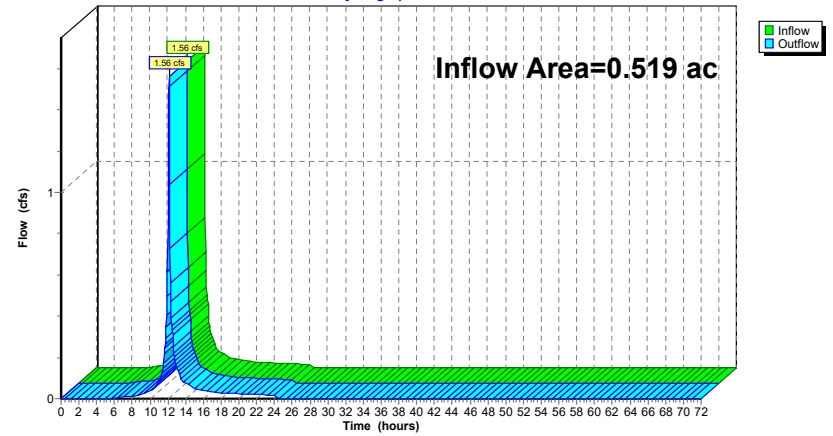

14850_Existing-Drainage-Areas

NOAA 24-hr C NOAA 2-yr Rainfall=3.40"

Prepared by {enter your company name here}

Printed 4/6/2022

HydroCAD® 10.10-7a s/n 00546 © 2021 HydroCAD Software Solutions LLC

Page 79

Summary for Reach CB3: EX-CB3

[40] Hint: Not Described (Outflow=Inflow)

Inflow Area = 0.265 ac, 100.00% Impervious, Inflow Depth = 3.17" for NOAA 2-yr event
Inflow = 0.93 cfs @ 12.13 hrs, Volume= 0.070 af
Outflow = 0.93 cfs @ 12.13 hrs, Volume= 0.070 af, Atten= 0%, Lag= 0.0 min
Routed to Reach DP-1 : French Rodney Blvd 14" Outfall

Routing by Stor-Ind+Trans method, Time Span= 0.00-72.00 hrs, dt= 0.05 hrs

Reach CB3: EX-CB3

Hydrograph

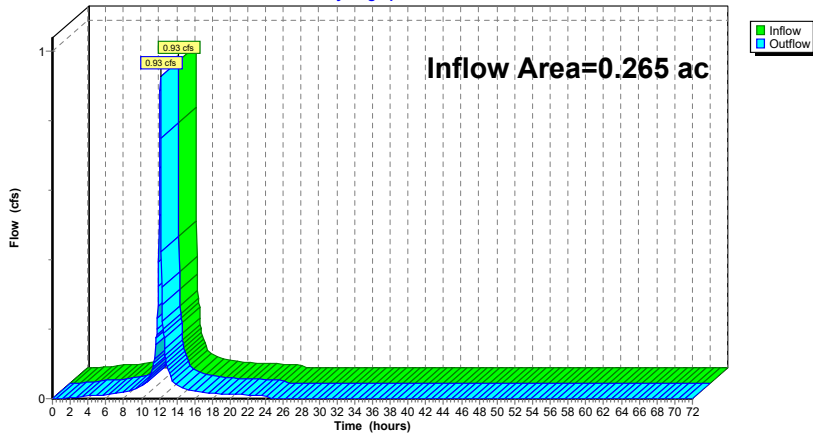

14850_Existing-Drainage-Areas

NOAA 24-hr C NOAA 2-yr Rainfall=3.40"

Prepared by {enter your company name here}

Printed 4/6/2022

HydroCAD® 10.10-7a s/n 00546 © 2021 HydroCAD Software Solutions LLC

Page 80

Summary for Reach CB4: EX-CB4

[40] Hint: Not Described (Outflow=Inflow)

Inflow Area = 0.450 ac, 58.17% Impervious, Inflow Depth = 2.18" for NOAA 2-yr event
Inflow = 1.23 cfs @ 12.13 hrs, Volume= 0.082 af
Outflow = 1.23 cfs @ 12.13 hrs, Volume= 0.082 af, Atten= 0%, Lag= 0.0 min
Routed to Reach DP-1 : French Rodney Blvd 14" Outfall

Routing by Stor-Ind+Trans method, Time Span= 0.00-72.00 hrs, dt= 0.05 hrs

Reach CB4: EX-CB4

Hydrograph

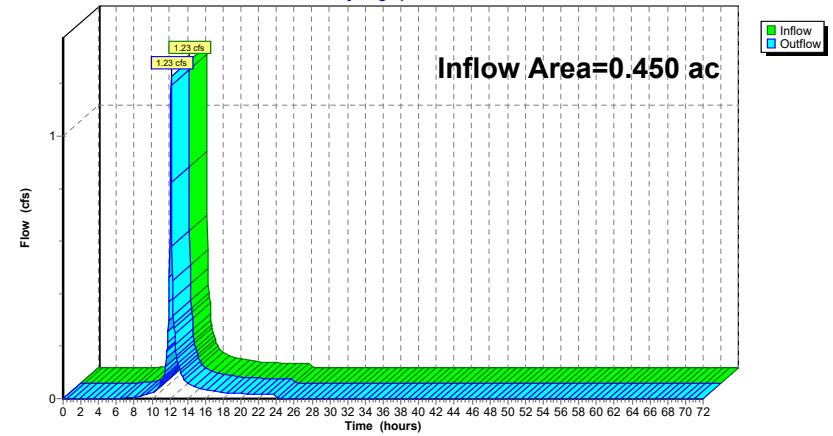

14850_Existing-Drainage-Areas

NOAA 24-hr C NOAA 2-yr Rainfall=3.40"

Prepared by {enter your company name here}

Printed 4/6/2022

HydroCAD® 10.10-7a s/n 00546 © 2021 HydroCAD Software Solutions LLC

Page 81

Summary for Reach CB5: EX-CB5

[40] Hint: Not Described (Outflow=Inflow)

Inflow Area = 0.527 ac, 57.51% Impervious, Inflow Depth = 2.18" for NOAA 2-yr event
Inflow = 1.44 cfs @ 12.13 hrs, Volume= 0.096 af
Outflow = 1.44 cfs @ 12.13 hrs, Volume= 0.096 af, Atten= 0%, Lag= 0.0 min
Routed to Reach DP-2 : PORTLAND STREET DRAINAGE

Routing by Stor-Ind+Trans method, Time Span= 0.00-72.00 hrs, dt= 0.05 hrs

Reach CB5: EX-CB5

Hydrograph

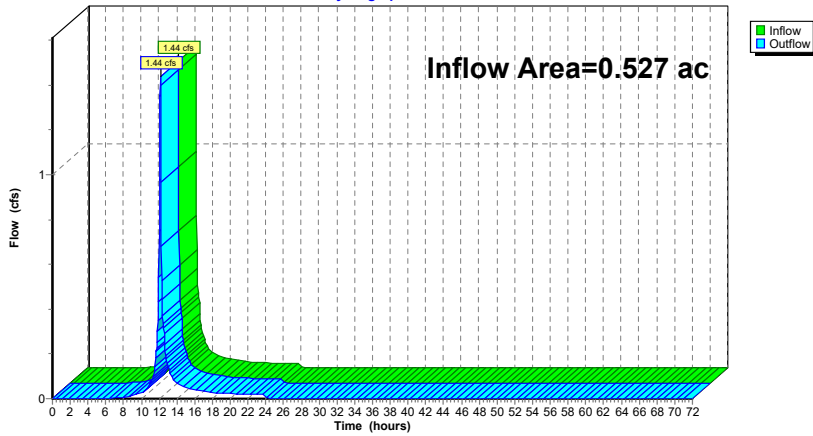

14850_Existing-Drainage-Areas

NOAA 24-hr C NOAA 2-yr Rainfall=3.40"

Prepared by {enter your company name here}

Printed 4/6/2022

HydroCAD® 10.10-7a s/n 00546 © 2021 HydroCAD Software Solutions LLC

Page 82

Summary for Reach CB6: EX-CB6

[40] Hint: Not Described (Outflow=Inflow)

Inflow Area = 0.793 ac, 93.00% Impervious, Inflow Depth = 2.95" for NOAA 2-yr event
Inflow = 2.69 cfs @ 12.13 hrs, Volume= 0.195 af
Outflow = 2.69 cfs @ 12.13 hrs, Volume= 0.195 af, Atten= 0%, Lag= 0.0 min
Routed to Reach DP-2 : PORTLAND STREET DRAINAGE

Routing by Stor-Ind+Trans method, Time Span= 0.00-72.00 hrs, dt= 0.05 hrs

Reach CB6: EX-CB6

Hydrograph

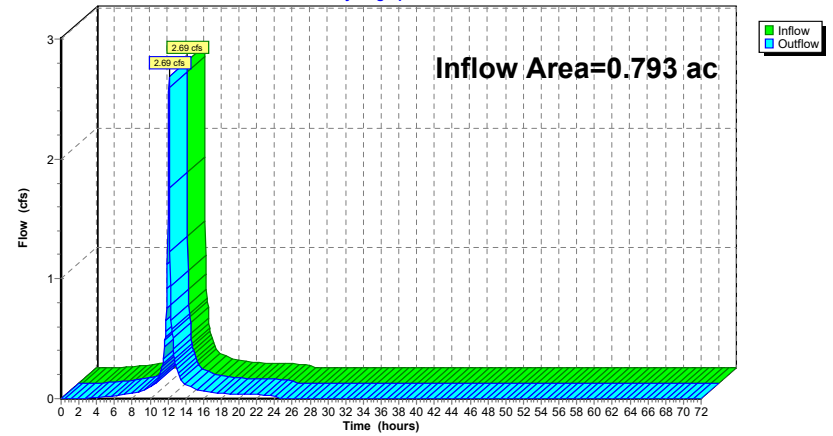

14850_Existing-Drainage-Areas

NOAA 24-hr C NOAA 2-yr Rainfall=3.40"

Prepared by {enter your company name here}

Printed 4/6/2022

HydroCAD® 10.10-7a s/n 00546 © 2021 HydroCAD Software Solutions LLC

Page 83

Summary for Reach CB7: EX-CB7

[40] Hint: Not Described (Outflow=Inflow)

Inflow Area = 0.578 ac, 51.84% Impervious, Inflow Depth = 2.01" for NOAA 2-yr event
Inflow = 1.47 cfs @ 12.13 hrs, Volume= 0.097 af
Outflow = 1.47 cfs @ 12.13 hrs, Volume= 0.097 af, Atten= 0%, Lag= 0.0 min
Routed to Reach DP-2 : PORTLAND STREET DRAINAGE

Routing by Stor-Ind+Trans method, Time Span= 0.00-72.00 hrs, dt= 0.05 hrs

Reach CB7: EX-CB7

Hydrograph

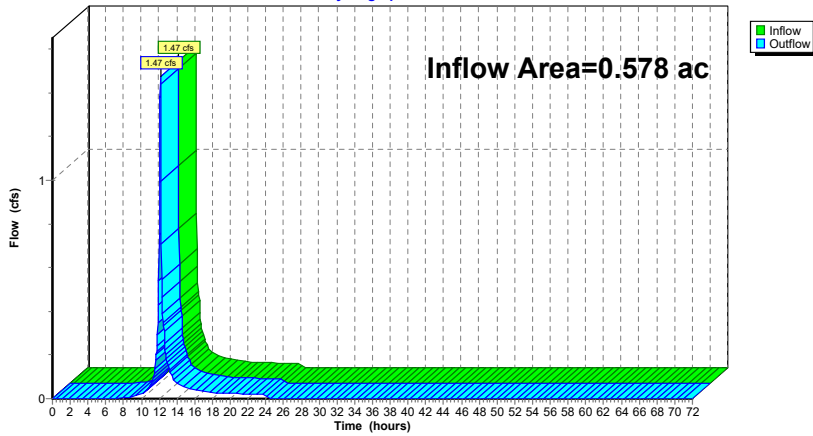

14850_Existing-Drainage-Areas

NOAA 24-hr C NOAA 2-yr Rainfall=3.40"

Prepared by {enter your company name here}

Printed 4/6/2022

HydroCAD® 10.10-7a s/n 00546 © 2021 HydroCAD Software Solutions LLC

Page 84

Summary for Reach CB8: EX-CB8

[40] Hint: Not Described (Outflow=Inflow)

Inflow Area = 3.367 ac, 50.27% Impervious, Inflow Depth = 2.03" for NOAA 2-yr event
Inflow = 8.63 cfs @ 12.13 hrs, Volume= 0.568 af
Outflow = 8.63 cfs @ 12.13 hrs, Volume= 0.568 af, Atten= 0%, Lag= 0.0 min
Routed to Reach DP-2 : PORTLAND STREET DRAINAGE

Routing by Stor-Ind+Trans method, Time Span= 0.00-72.00 hrs, dt= 0.05 hrs

Reach CB8: EX-CB8

Hydrograph

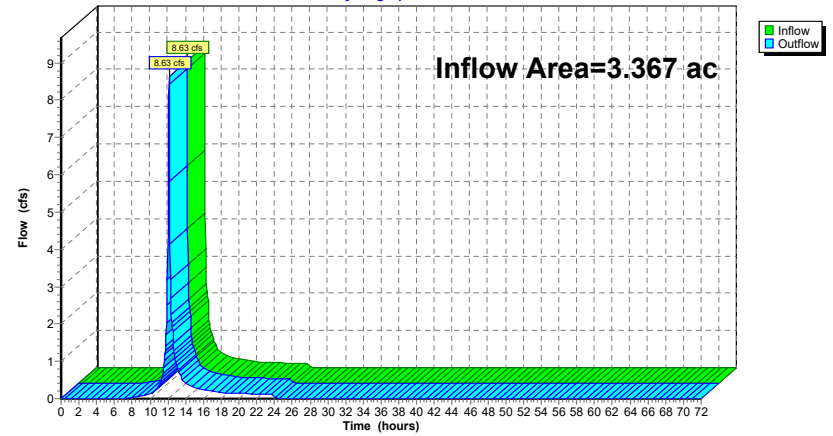

14850_Existing-Drainage-Areas

NOAA 24-hr C NOAA 2-yr Rainfall=3.40"

Prepared by {enter your company name here}

Printed 4/6/2022

HydroCAD® 10.10-7a s/n 00546 © 2021 HydroCAD Software Solutions LLC

Page 85

Summary for Reach CB9: EX CB-9

[40] Hint: Not Described (Outflow=Inflow)

Inflow Area = 0.829 ac, 94.03% Impervious, Inflow Depth = 3.06" for NOAA 2-yr event
Inflow = 2.86 cfs @ 12.13 hrs, Volume= 0.211 af
Outflow = 2.86 cfs @ 12.13 hrs, Volume= 0.211 af, Atten= 0%, Lag= 0.0 min
Routed to Reach DP-2 : PORTLAND STREET DRAINAGE

Routing by Stor-Ind+Trans method, Time Span= 0.00-72.00 hrs, dt= 0.05 hrs

Reach CB9: EX CB-9

Hydrograph

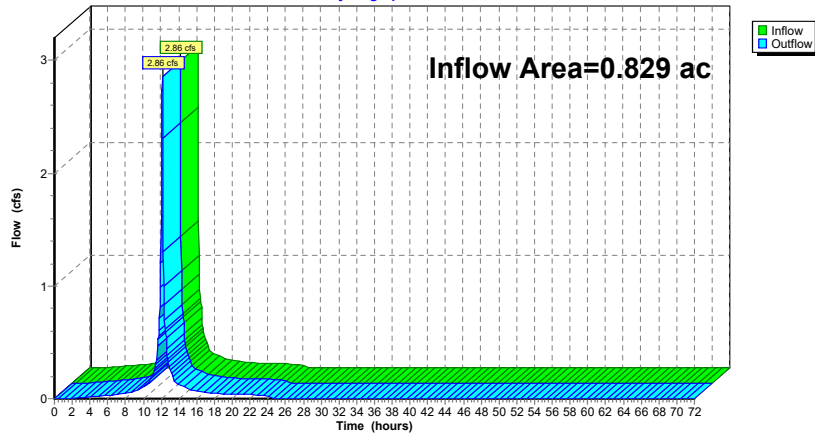

14850_Existing-Drainage-Areas

NOAA 24-hr C NOAA 2-yr Rainfall=3.40"

Prepared by {enter your company name here}

Printed 4/6/2022

HydroCAD® 10.10-7a s/n 00546 © 2021 HydroCAD Software Solutions LLC

Page 86

Summary for Reach DP-1: French Rodney Blvd 14" Outfall

[40] Hint: Not Described (Outflow=Inflow)

Inflow Area = 1.994 ac, 68.32% Impervious, Inflow Depth = 2.41" for NOAA 2-yr event
Inflow = 5.86 cfs @ 12.13 hrs, Volume= 0.401 af
Outflow = 5.86 cfs @ 12.13 hrs, Volume= 0.401 af, Atten= 0%, Lag= 0.0 min

Routing by Stor-Ind+Trans method, Time Span= 0.00-72.00 hrs, dt= 0.05 hrs

Reach DP-1: French Rodney Blvd 14" Outfall

Hydrograph

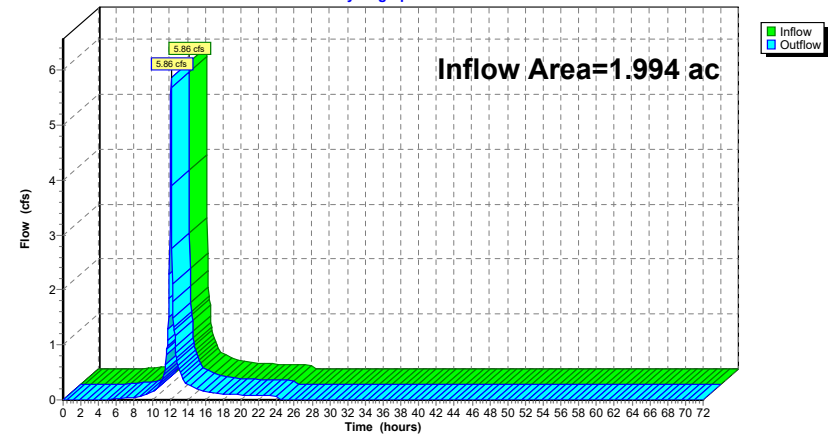

14850_Existing-Drainage-Areas

NOAA 24-hr C NOAA 2-yr Rainfall=3.40"

Prepared by {enter your company name here}

Printed 4/6/2022

HydroCAD® 10.10-7a s/n 00546 © 2021 HydroCAD Software Solutions LLC

Page 87

Summary for Reach DP-2: PORTLAND STREET DRAINAGE

[40] Hint: Not Described (Outflow=Inflow)

Inflow Area = 6.696 ac, 62.59% Impervious, Inflow Depth = 2.30" for NOAA 2-yr event
 Inflow = 18.76 cfs @ 12.13 hrs, Volume= 1.282 af
 Outflow = 18.76 cfs @ 12.13 hrs, Volume= 1.282 af, Atten= 0%, Lag= 0.0 min

Routing by Stor-Ind+Trans method, Time Span= 0.00-72.00 hrs, dt= 0.05 hrs

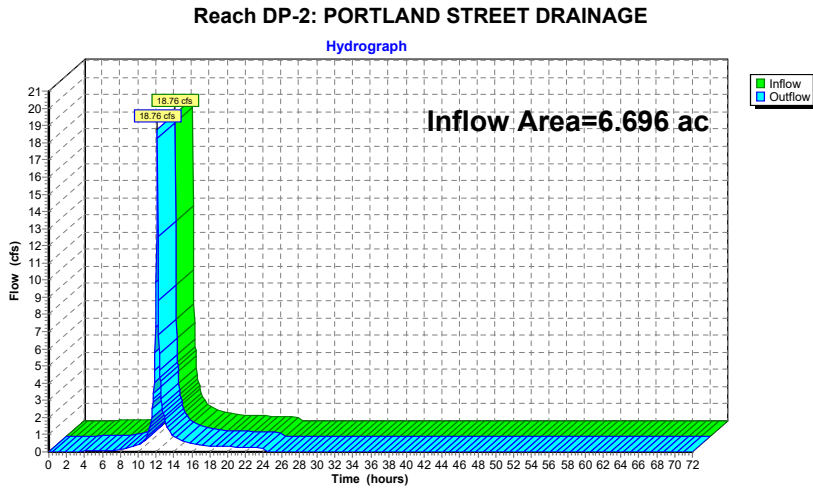

14850_Existing-Drainage-Areas

NOAA 24-hr C NOAA 25-yr Rainfall=6.04"

Prepared by {enter your company name here}

Printed 4/6/2022

HydroCAD® 10.10-7a s/n 00546 © 2021 HydroCAD Software Solutions LLC

Page 88

Time span=0.00-72.00 hrs, dt=0.05 hrs, 1441 points

Runoff by SCS TR-20 method, UH=SCS, Weighted-CN

Reach routing by Stor-Ind+Trans method - Pond routing by Stor-Ind method

Subcatchment1B: CB-1B (mix)	Runoff Area=33,097 sf 61.34% Impervious Runoff Depth=4.77" Tc=6.0 min CN=89 Runoff=4.34 cfs 0.302 af
Subcatchment2: CB-2 (mix)	Runoff Area=22,628 sf 71.14% Impervious Runoff Depth=5.00" Tc=6.0 min CN=91 Runoff=3.05 cfs 0.216 af
Subcatchment3A: CB-3A (parking)	Runoff Area=7,758 sf 100.00% Impervious Runoff Depth=5.80" Tc=6.0 min CN=98 Runoff=1.11 cfs 0.086 af
Subcatchment3B: CB-3B (parking)	Runoff Area=3,797 sf 100.00% Impervious Runoff Depth=5.80" Tc=6.0 min CN=98 Runoff=0.54 cfs 0.042 af
Subcatchment5B: CB-5B (mix)	Runoff Area=22,974 sf 57.51% Impervious Runoff Depth=4.66" Tc=6.0 min CN=88 Runoff=2.97 cfs 0.205 af
Subcatchment6: CB-6 (mix)	Runoff Area=34,524 sf 93.00% Impervious Runoff Depth=5.57" Tc=6.0 min CN=96 Runoff=4.90 cfs 0.368 af
Subcatchment8B: CB-8B (mix)	Runoff Area=28,528 sf 54.52% Impervious Runoff Depth=4.56" Tc=6.0 min CN=87 Runoff=3.62 cfs 0.249 af
Subcatchment9: CB-9 (mix)	Runoff Area=36,104 sf 94.03% Impervious Runoff Depth=5.68" Tc=6.0 min CN=97 Runoff=5.15 cfs 0.393 af
Subcatchment10: CB-10 (parking)	Runoff Area=6,492 sf 100.00% Impervious Runoff Depth=5.80" Tc=6.0 min CN=98 Runoff=0.93 cfs 0.072 af
SubcatchmentCB-1: New CB South	Runoff Area=19,582 sf 58.17% Impervious Runoff Depth=4.66" Flow Length=512' Tc=6.0 min CN=88 Runoff=2.53 cfs 0.175 af
SubcatchmentCB-3: NEW CB SOUTH-	Runoff Area=25,183 sf 51.84% Impervious Runoff Depth=4.45" Flow Length=635' Tc=6.0 min CN=86 Runoff=3.14 cfs 0.214 af
SubcatchmentCB-4: NEW CB NOTH -	Runoff Area=118,126 sf 49.24% Impervious Runoff Depth=4.45" Flow Length=822' Tc=6.0 min CN=86 Runoff=14.73 cfs 1.005 af
SubcatchmentCB-5: NEW CB -	Runoff Area=19,743 sf 50.83% Impervious Runoff Depth=4.45" Flow Length=574' Tc=6.0 min CN=86 Runoff=2.46 cfs 0.168 af
Reach CB1: EX CB-1	Inflow=4.34 cfs 0.302 af Outflow=4.34 cfs 0.302 af
Reach CB10: EX-CB10	Inflow=0.93 cfs 0.072 af Outflow=0.93 cfs 0.072 af
Reach CB11: EX-CB11	Inflow=2.46 cfs 0.168 af Outflow=2.46 cfs 0.168 af

14850_Existing-Drainage-Areas

NOAA 24-hr C NOAA 25-yr Rainfall=6.04"

Prepared by {enter your company name here}

Printed 4/6/2022

HydroCAD® 10.10-7a s/n 00546 © 2021 HydroCAD Software Solutions LLC

Page 89

Reach CB2: EX-CB2	Inflow=3.05 cfs 0.216 af Outflow=3.05 cfs 0.216 af
Reach CB3: EX-CB3	Inflow=1.66 cfs 0.128 af Outflow=1.66 cfs 0.128 af
Reach CB4: EX-CB4	Inflow=2.53 cfs 0.175 af Outflow=2.53 cfs 0.175 af
Reach CB5: EX-CB5	Inflow=2.97 cfs 0.205 af Outflow=2.97 cfs 0.205 af
Reach CB6: EX-CB6	Inflow=4.90 cfs 0.368 af Outflow=4.90 cfs 0.368 af
Reach CB7: EX-CB7	Inflow=3.14 cfs 0.214 af Outflow=3.14 cfs 0.214 af
Reach CB8: EX-CB8	Inflow=18.36 cfs 1.254 af Outflow=18.36 cfs 1.254 af
Reach CB9: EX CB-9	Inflow=5.15 cfs 0.393 af Outflow=5.15 cfs 0.393 af
Reach DP-1: French Rodney Blvd 14" Outfall	Inflow=11.57 cfs 0.822 af Outflow=11.57 cfs 0.822 af
Reach DP-2: PORTLANDSTREET DRAINAGE	Inflow=37.90 cfs 2.673 af Outflow=37.90 cfs 2.673 af

Total Runoff Area = 8.690 ac Runoff Volume = 3.495 af Average Runoff Depth = 4.83"
36.09% Pervious = 3.136 ac 63.91% Impervious = 5.554 ac

14850_Existing-Drainage-Areas

NOAA 24-hr C NOAA 25-yr Rainfall=6.04"

Prepared by {enter your company name here}

Printed 4/6/2022

HydroCAD® 10.10-7a s/n 00546 © 2021 HydroCAD Software Solutions LLC

Page 90

Summary for Subcatchment 1B: CB-1B (mix)

Runoff = 4.34 cfs @ 12.13 hrs, Volume= 0.302 af, Depth= 4.77"
Routed to Reach CB1 : EX CB-1

Runoff by SCS TR-20 method, UH=SCS, Weighted-CN, Time Span= 0.00-72.00 hrs, dt= 0.05 hrs
NOAA 24-hr C NOAA 25-yr Rainfall=6.04"

Area (sf)	CN	Description
20,636	83	1/4 acre lots, 38% imp, HSG C
12,461	98	Paved parking, HSG C
33,097	89	Weighted Average
12,794		38.66% Pervious Area
20,303		61.34% Impervious Area

Tc (min)	Length (feet)	Slope (ft/ft)	Velocity (ft/sec)	Capacity (cfs)	Description
6.0					Direct Entry, residential & parking areas

Subcatchment 1B: CB-1B (mix)

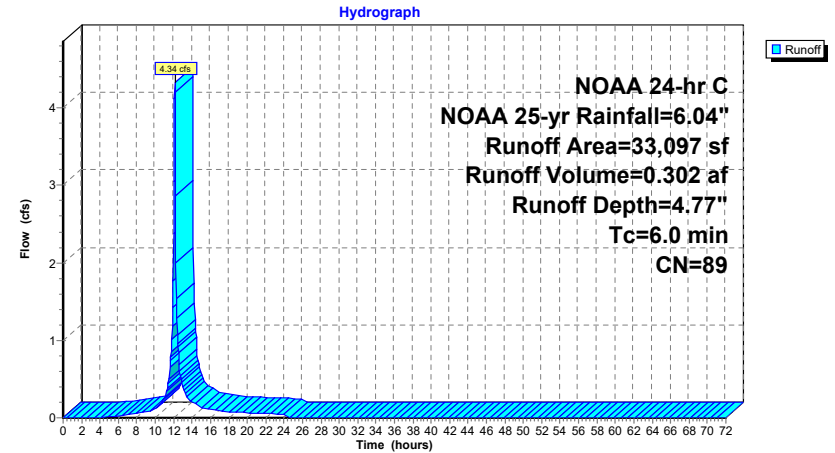

14850_Existing-Drainage-Areas

NOAA 24-hr C NOAA 25-yr Rainfall=6.04"

Prepared by {enter your company name here}

Printed 4/6/2022

HydroCAD® 10.10-7a s/n 00546 © 2021 HydroCAD Software Solutions LLC

Page 91

Summary for Subcatchment 2: CB-2 (mix)

Runoff = 3.05 cfs @ 12.13 hrs, Volume= 0.216 af, Depth= 5.00"
Routed to Reach CB2 : EX-CB2

Runoff by SCS TR-20 method, UH=SCS, Weighted-CN, Time Span= 0.00-72.00 hrs, dt= 0.05 hrs
NOAA 24-hr C NOAA 25-yr Rainfall=6.04"

Area (sf)	CN	Description
10,533	83	1/4 acre lots, 38% imp, HSG C
12,095	98	Paved parking, HSG C
22,628	91	Weighted Average
6,530		28.86% Pervious Area
16,098		71.14% Impervious Area

Tc (min)	Length (feet)	Slope (ft/ft)	Velocity (ft/sec)	Capacity (cfs)	Description
6.0					Direct Entry, residential & parking areas

Subcatchment 2: CB-2 (mix)

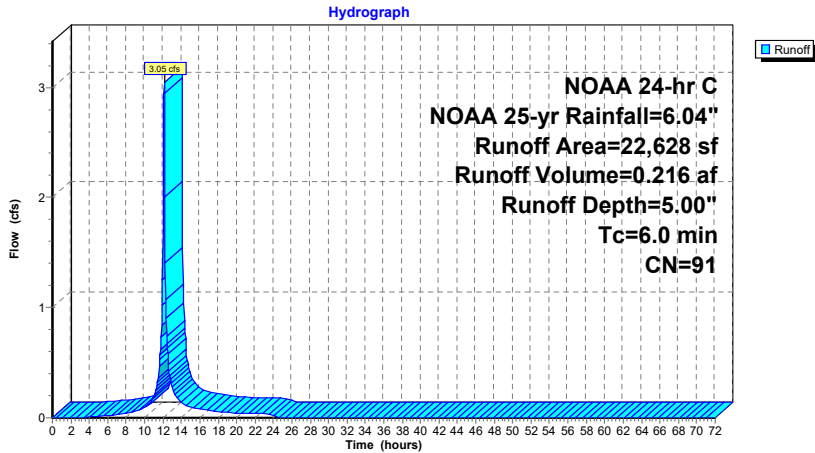

14850_Existing-Drainage-Areas

NOAA 24-hr C NOAA 25-yr Rainfall=6.04"

Prepared by {enter your company name here}

Printed 4/6/2022

HydroCAD® 10.10-7a s/n 00546 © 2021 HydroCAD Software Solutions LLC

Page 92

Summary for Subcatchment 3A: CB-3A (parking)

Runoff = 1.11 cfs @ 12.13 hrs, Volume= 0.086 af, Depth= 5.80"
Routed to Reach CB3 : EX-CB3

Runoff by SCS TR-20 method, UH=SCS, Weighted-CN, Time Span= 0.00-72.00 hrs, dt= 0.05 hrs
NOAA 24-hr C NOAA 25-yr Rainfall=6.04"

Area (sf)	CN	Description
7,758	98	Paved parking, HSG C
7,758		100.00% Impervious Area

Tc (min)	Length (feet)	Slope (ft/ft)	Velocity (ft/sec)	Capacity (cfs)	Description
6.0					Direct Entry, residential & parking areas

Subcatchment 3A: CB-3A (parking)

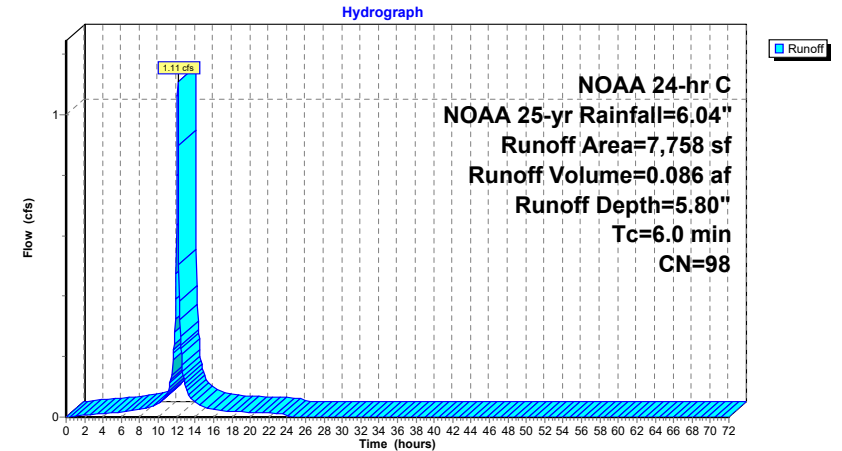

14850_Existing-Drainage-Areas

NOAA 24-hr C NOAA 25-yr Rainfall=6.04"

Prepared by {enter your company name here}

Printed 4/6/2022

HydroCAD® 10.10-7a s/n 00546 © 2021 HydroCAD Software Solutions LLC

Page 93

Summary for Subcatchment 3B: CB-3B (parking)

Runoff = 0.54 cfs @ 12.13 hrs, Volume= 0.042 af, Depth= 5.80"
Routed to Reach CB3 : EX-CB3

Runoff by SCS TR-20 method, UH=SCS, Weighted-CN, Time Span= 0.00-72.00 hrs, dt= 0.05 hrs
NOAA 24-hr C NOAA 25-yr Rainfall=6.04"

Area (sf)	CN	Description
3,797	98	Paved parking, HSG C
3,797		100.00% Impervious Area

Tc (min)	Length (feet)	Slope (ft/ft)	Velocity (ft/sec)	Capacity (cfs)	Description
6.0					Direct Entry, residential & parking areas

Subcatchment 3B: CB-3B (parking)

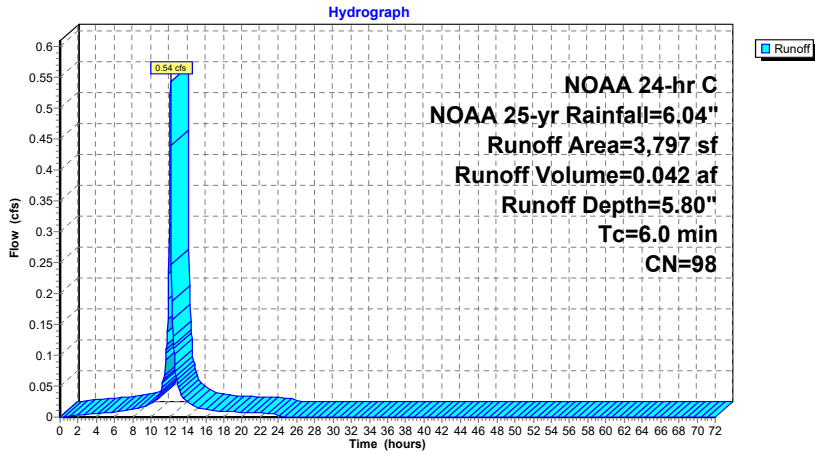

14850_Existing-Drainage-Areas

NOAA 24-hr C NOAA 25-yr Rainfall=6.04"

Prepared by {enter your company name here}

Printed 4/6/2022

HydroCAD® 10.10-7a s/n 00546 © 2021 HydroCAD Software Solutions LLC

Page 94

Summary for Subcatchment 5B: CB-5B (mix)

Runoff = 2.97 cfs @ 12.13 hrs, Volume= 0.205 af, Depth= 4.66"
Routed to Reach CB5 : EX-CB5

Runoff by SCS TR-20 method, UH=SCS, Weighted-CN, Time Span= 0.00-72.00 hrs, dt= 0.05 hrs
NOAA 24-hr C NOAA 25-yr Rainfall=6.04"

Area (sf)	CN	Description
15,743	83	1/4 acre lots, 38% imp, HSG C
7,231	98	Paved parking, HSG C
22,974	88	Weighted Average
9,761		42.49% Pervious Area
13,213		57.51% Impervious Area

Tc (min)	Length (feet)	Slope (ft/ft)	Velocity (ft/sec)	Capacity (cfs)	Description
6.0					Direct Entry, residential & parking areas

Subcatchment 5B: CB-5B (mix)

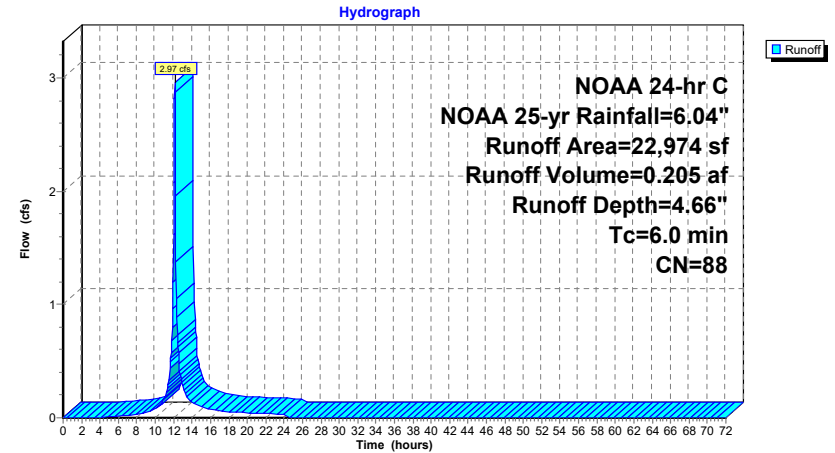

14850_Existing-Drainage-Areas

NOAA 24-hr C NOAA 25-yr Rainfall=6.04"

Prepared by {enter your company name here}

Printed 4/6/2022

HydroCAD® 10.10-7a s/n 00546 © 2021 HydroCAD Software Solutions LLC

Page 95

Summary for Subcatchment 6: CB-6 (mix)

Runoff = 4.90 cfs @ 12.13 hrs, Volume= 0.368 af, Depth= 5.57"
Routed to Reach CB6 : EX-CB6

Runoff by SCS TR-20 method, UH=SCS, Weighted-CN, Time Span= 0.00-72.00 hrs, dt= 0.05 hrs
NOAA 24-hr C NOAA 25-yr Rainfall=6.04"

Area (sf)	CN	Description
3,898	83	1/4 acre lots, 38% imp, HSG C
30,626	98	Paved parking, HSG C
34,524	96	Weighted Average
2,417		7.00% Pervious Area
32,107		93.00% Impervious Area

Tc (min)	Length (feet)	Slope (ft/ft)	Velocity (ft/sec)	Capacity (cfs)	Description
6.0					Direct Entry, residential & parking areas

Subcatchment 6: CB-6 (mix)

Hydrograph

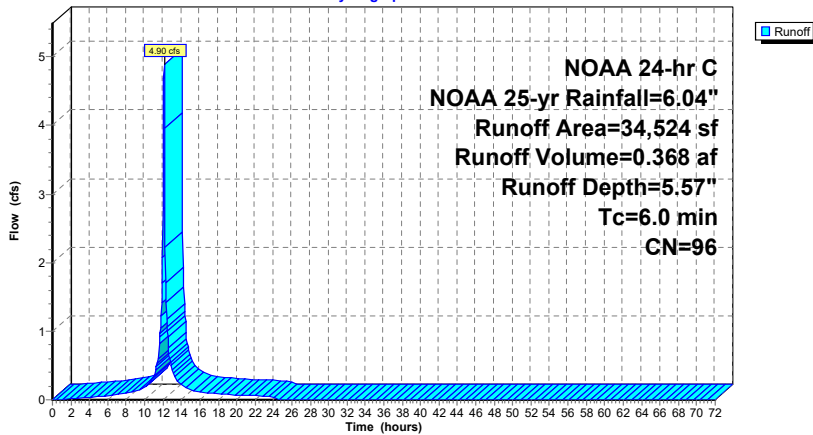

14850_Existing-Drainage-Areas

NOAA 24-hr C NOAA 25-yr Rainfall=6.04"

Prepared by {enter your company name here}

Printed 4/6/2022

HydroCAD® 10.10-7a s/n 00546 © 2021 HydroCAD Software Solutions LLC

Page 96

Summary for Subcatchment 8B: CB-8B (mix)

Runoff = 3.62 cfs @ 12.13 hrs, Volume= 0.249 af, Depth= 4.56"
Routed to Reach CB8 : EX-CB8

Runoff by SCS TR-20 method, UH=SCS, Weighted-CN, Time Span= 0.00-72.00 hrs, dt= 0.05 hrs
NOAA 24-hr C NOAA 25-yr Rainfall=6.04"

Area (sf)	CN	Description
20,925	83	1/4 acre lots, 38% imp, HSG C
7,603	98	Paved parking, HSG C
28,528	87	Weighted Average
12,974		45.48% Pervious Area
15,555		54.52% Impervious Area

Tc (min)	Length (feet)	Slope (ft/ft)	Velocity (ft/sec)	Capacity (cfs)	Description
6.0					Direct Entry, residential & parking areas

Subcatchment 8B: CB-8B (mix)

Hydrograph

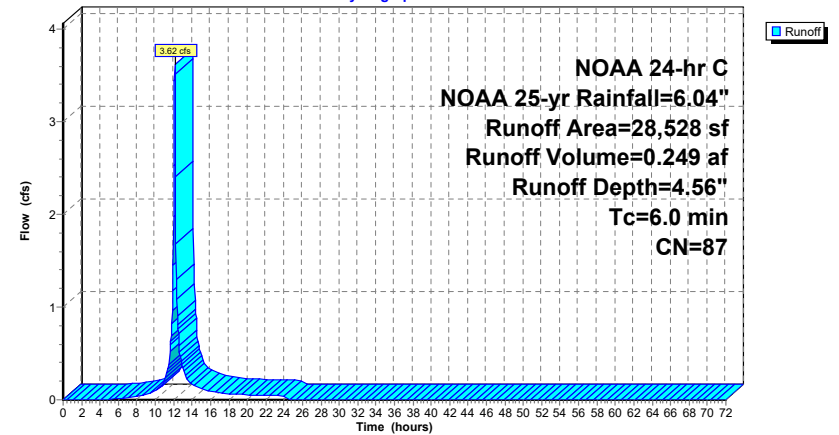

14850_Existing-Drainage-Areas

NOAA 24-hr C NOAA 25-yr Rainfall=6.04"

Prepared by {enter your company name here}

Printed 4/6/2022

HydroCAD® 10.10-7a s/n 00546 © 2021 HydroCAD Software Solutions LLC

Page 97

Summary for Subcatchment 9: CB-9 (mix)

Runoff = 5.15 cfs @ 12.13 hrs, Volume= 0.393 af, Depth= 5.68"
Routed to Reach CB9 : EX CB-9

Runoff by SCS TR-20 method, UH=SCS, Weighted-CN, Time Span= 0.00-72.00 hrs, dt= 0.05 hrs
NOAA 24-hr C NOAA 25-yr Rainfall=6.04"

Area (sf)	CN	Description
3,474	83	1/4 acre lots, 38% imp, HSG C
32,630	98	Paved parking, HSG C
36,104	97	Weighted Average
2,154		5.97% Pervious Area
33,950		94.03% Impervious Area

Tc (min)	Length (feet)	Slope (ft/ft)	Velocity (ft/sec)	Capacity (cfs)	Description
6.0					Direct Entry, residential & parking areas

Subcatchment 9: CB-9 (mix)

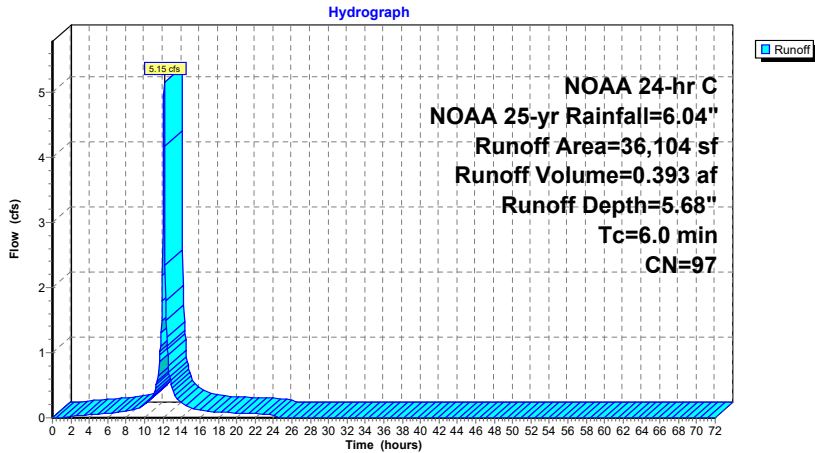

14850_Existing-Drainage-Areas

NOAA 24-hr C NOAA 25-yr Rainfall=6.04"

Prepared by {enter your company name here}

Printed 4/6/2022

HydroCAD® 10.10-7a s/n 00546 © 2021 HydroCAD Software Solutions LLC

Page 98

Summary for Subcatchment 10: CB-10 (parking)

Runoff = 0.93 cfs @ 12.13 hrs, Volume= 0.072 af, Depth= 5.80"
Routed to Reach CB10 : EX-CB10

Runoff by SCS TR-20 method, UH=SCS, Weighted-CN, Time Span= 0.00-72.00 hrs, dt= 0.05 hrs
NOAA 24-hr C NOAA 25-yr Rainfall=6.04"

Area (sf)	CN	Description
6,492	98	Paved parking, HSG C
6,492		100.00% Impervious Area

Tc (min)	Length (feet)	Slope (ft/ft)	Velocity (ft/sec)	Capacity (cfs)	Description
6.0					Direct Entry, residential & parking areas

Subcatchment 10: CB-10 (parking)

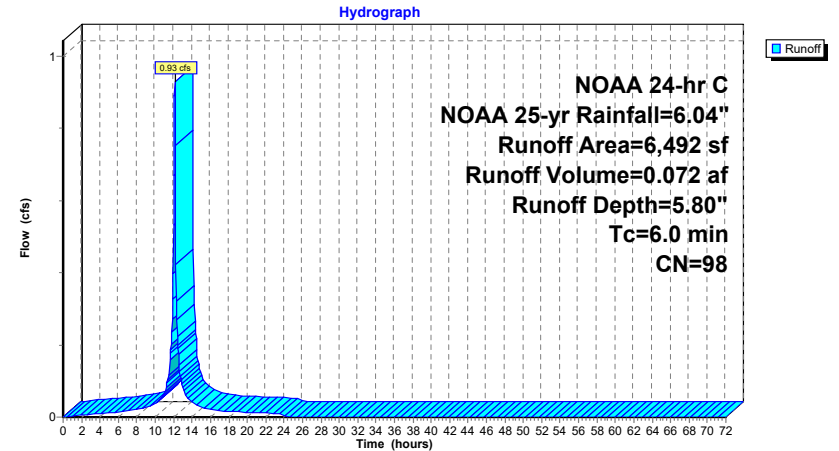

14850_Existing-Drainage-Areas

NOAA 24-hr C NOAA 25-yr Rainfall=6.04"

Prepared by {enter your company name here}

Printed 4/6/2022

HydroCAD® 10.10-7a s/n 00546 © 2021 HydroCAD Software Solutions LLC

Page 99

Summary for Subcatchment CB-1: New CB South (Seymour Street)

Runoff = 2.53 cfs @ 12.13 hrs, Volume= 0.175 af, Depth= 4.66"
Routed to Reach CB4 : EX-CB4

Runoff by SCS TR-20 method, UH=SCS, Weighted-CN, Time Span= 0.00-72.00 hrs, dt= 0.05 hrs
NOAA 24-hr C NOAA 25-yr Rainfall=6.04"

Area (sf)	CN	Description
13,211	83	1/4 acre lots, 38% imp, HSG C
* 6,371	98	Roadway
19,582	88	Weighted Average
8,191		41.83% Pervious Area
11,391		58.17% Impervious Area

Tc (min)	Length (feet)	Slope (ft/ft)	Velocity (ft/sec)	Capacity (cfs)	Description
0.6	50	0.0300	1.45		Sheet Flow, A-B Smooth surfaces n= 0.011 P2= 3.40"
2.4	462	0.0249	3.20		Shallow Concentrated Flow, Paved Paved Kv= 20.3 fps
3.0					Direct Entry, Direct entry to 6
6.0	512	Total			

Subcatchment CB-1: New CB South (Seymour Street)

Hydrograph

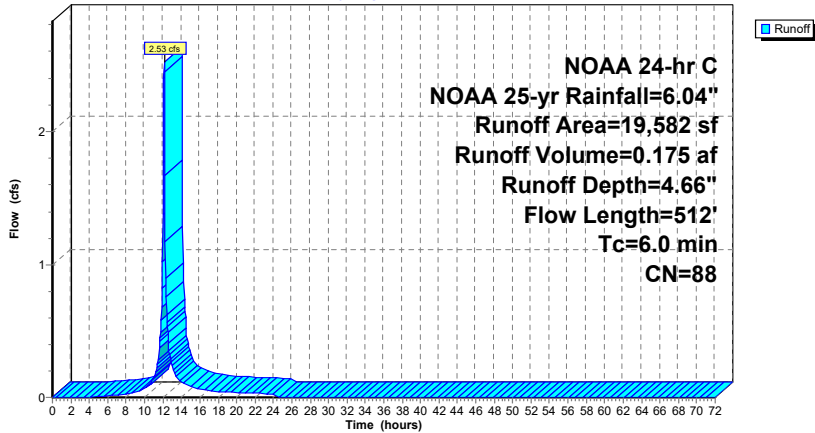

14850_Existing-Drainage-Areas

NOAA 24-hr C NOAA 25-yr Rainfall=6.04"

Prepared by {enter your company name here}

Printed 4/6/2022

HydroCAD® 10.10-7a s/n 00546 © 2021 HydroCAD Software Solutions LLC

Page 100

Summary for Subcatchment CB-3: NEW CB SOUTH- HUDSON ST

Runoff = 3.14 cfs @ 12.13 hrs, Volume= 0.214 af, Depth= 4.45"
Routed to Reach CB7 : EX-CB7

Runoff by SCS TR-20 method, UH=SCS, Weighted-CN, Time Span= 0.00-72.00 hrs, dt= 0.05 hrs
NOAA 24-hr C NOAA 25-yr Rainfall=6.04"

Area (sf)	CN	Description
19,562	83	1/4 acre lots, 38% imp, HSG C
* 5,621	98	Roadway
25,183	86	Weighted Average
12,128		48.16% Pervious Area
13,055		51.84% Impervious Area

Tc (min)	Length (feet)	Slope (ft/ft)	Velocity (ft/sec)	Capacity (cfs)	Description
0.5	50	0.0444	1.70		Sheet Flow, A-B (sheet flow) Smooth surfaces n= 0.011 P2= 3.40"
3.0	585	0.0256	3.25		Shallow Concentrated Flow, B-C Paved Kv= 20.3 fps
2.5					Direct Entry, direct entry to 6
6.0	635	Total			

Subcatchment CB-3: NEW CB SOUTH- HUDSON ST

Hydrograph

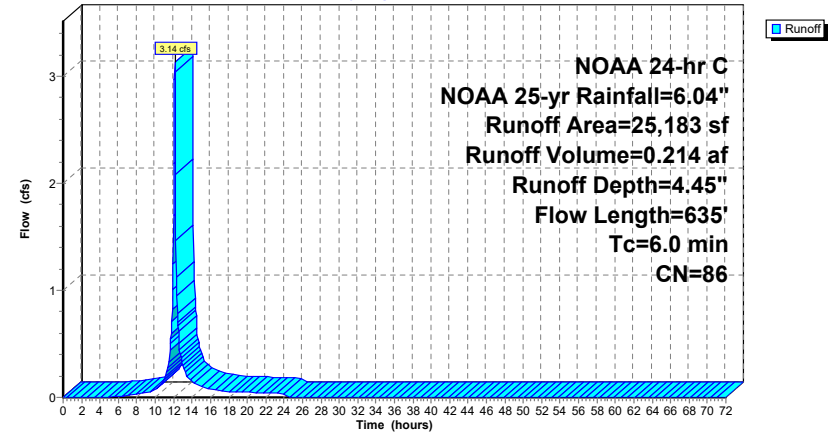

14850_Existing-Drainage-Areas

NOAA 24-hr C NOAA 25-yr Rainfall=6.04"

Prepared by {enter your company name here}

Printed 4/6/2022

HydroCAD® 10.10-7a s/n 00546 © 2021 HydroCAD Software Solutions LLC

Page 101

Summary for Subcatchment CB-4: NEW CB NOTH - HUDSON STREET

Runoff = 14.73 cfs @ 12.13 hrs, Volume= 1.005 af, Depth= 4.45"
Routed to Reach CB8 : EX-CB8

Runoff by SCS TR-20 method, UH=SCS, Weighted-CN, Time Span= 0.00-72.00 hrs, dt= 0.05 hrs
NOAA 24-hr C NOAA 25-yr Rainfall=6.04"

Area (sf)	CN	Description
96,716	83	1/4 acre lots, 38% imp, HSG C
* 21,410	98	Roadway
118,126	86	Weighted Average
59,964		50.76% Pervious Area
58,162		49.24% Impervious Area

Tc (min)	Length (feet)	Slope (ft/ft)	Velocity (ft/sec)	Capacity (cfs)	Description
0.5	50	0.0500	1.78		Sheet Flow, A-B (sheet flow) Smooth surfaces n= 0.011 P2= 3.40"
4.0	772	0.0245	3.18		Shallow Concentrated Flow, B-C (shallow concentrated) Paved Kv= 20.3 fps
1.5					Direct Entry, direct entry to 6
6.0	822	Total			

Subcatchment CB-4: NEW CB NOTH - HUDSON STREET

Hydrograph

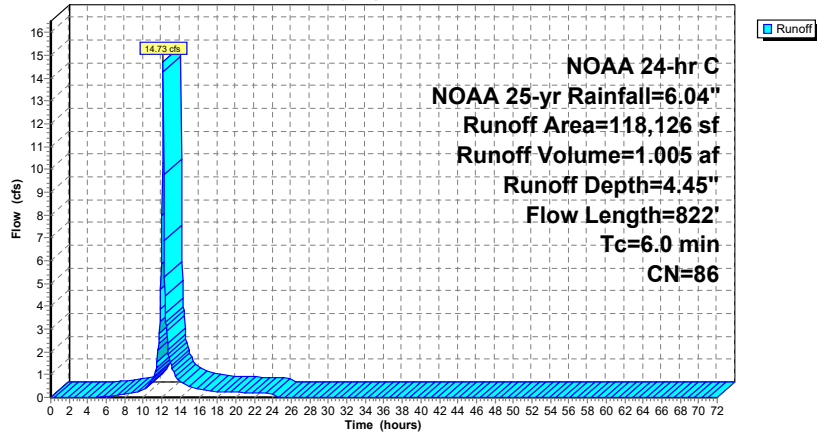

14850_Existing-Drainage-Areas

NOAA 24-hr C NOAA 25-yr Rainfall=6.04"

Prepared by {enter your company name here}

Printed 4/6/2022

HydroCAD® 10.10-7a s/n 00546 © 2021 HydroCAD Software Solutions LLC

Page 102

Summary for Subcatchment CB-5: NEW CB - PORTLAND ST SOUTH

Runoff = 2.46 cfs @ 12.13 hrs, Volume= 0.168 af, Depth= 4.45"
Routed to Reach CB11 : EX-CB11

Runoff by SCS TR-20 method, UH=SCS, Weighted-CN, Time Span= 0.00-72.00 hrs, dt= 0.05 hrs
NOAA 24-hr C NOAA 25-yr Rainfall=6.04"

Area (sf)	CN	Description
15,657	83	1/4 acre lots, 38% imp, HSG C
* 4,086	98	Roadway
19,743	86	Weighted Average
9,707		49.17% Pervious Area
10,036		50.83% Impervious Area

Tc (min)	Length (feet)	Slope (ft/ft)	Velocity (ft/sec)	Capacity (cfs)	Description
0.5	50	0.0500	1.78		Sheet Flow, A-B (sheet flow) Smooth surfaces n= 0.011 P2= 3.40"
2.3	524	0.0346	3.78		Shallow Concentrated Flow, B-C (shallow conc.) Paved Kv= 20.3 fps
3.2					Direct Entry, direct to 6
6.0	574	Total			

Subcatchment CB-5: NEW CB - PORTLAND ST SOUTH

Hydrograph

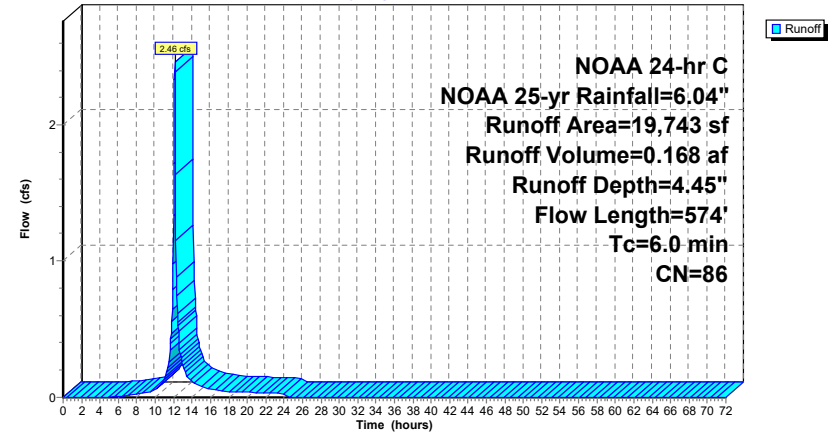

14850_Existing-Drainage-Areas

NOAA 24-hr C NOAA 25-yr Rainfall=6.04"

Prepared by {enter your company name here}

Printed 4/6/2022

HydroCAD® 10.10-7a s/n 00546 © 2021 HydroCAD Software Solutions LLC

Page 103

Summary for Reach CB1: EX CB-1

[40] Hint: Not Described (Outflow=Inflow)

Inflow Area = 0.760 ac, 61.34% Impervious, Inflow Depth = 4.77" for NOAA 25-yr event
Inflow = 4.34 cfs @ 12.13 hrs, Volume= 0.302 af
Outflow = 4.34 cfs @ 12.13 hrs, Volume= 0.302 af, Atten= 0%, Lag= 0.0 min
Routed to Reach DP-1 : French Rodney Blvd 14" Outfall

Routing by Stor-Ind+Trans method, Time Span= 0.00-72.00 hrs, dt= 0.05 hrs

Reach CB1: EX CB-1

Hydrograph

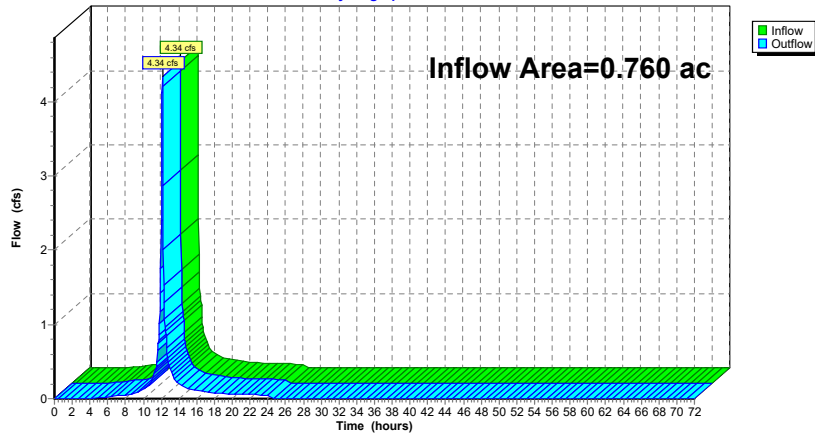

14850_Existing-Drainage-Areas

NOAA 24-hr C NOAA 25-yr Rainfall=6.04"

Prepared by {enter your company name here}

Printed 4/6/2022

HydroCAD® 10.10-7a s/n 00546 © 2021 HydroCAD Software Solutions LLC

Page 104

Summary for Reach CB10: EX-CB10

[40] Hint: Not Described (Outflow=Inflow)

Inflow Area = 0.149 ac, 100.00% Impervious, Inflow Depth = 5.80" for NOAA 25-yr event
Inflow = 0.93 cfs @ 12.13 hrs, Volume= 0.072 af
Outflow = 0.93 cfs @ 12.13 hrs, Volume= 0.072 af, Atten= 0%, Lag= 0.0 min
Routed to Reach DP-2 : PORTLAND STREET DRAINAGE

Routing by Stor-Ind+Trans method, Time Span= 0.00-72.00 hrs, dt= 0.05 hrs

Reach CB10: EX-CB10

Hydrograph

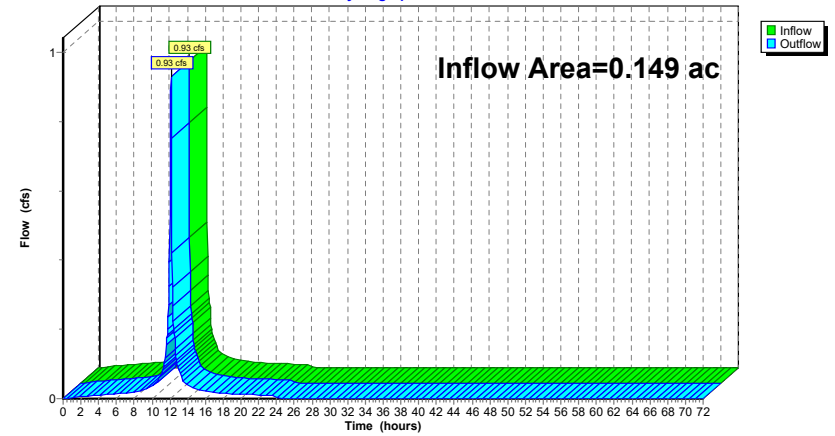

14850_Existing-Drainage-Areas

NOAA 24-hr C NOAA 25-yr Rainfall=6.04"

Prepared by {enter your company name here}

Printed 4/6/2022

HydroCAD® 10.10-7a s/n 00546 © 2021 HydroCAD Software Solutions LLC

Page 105

Summary for Reach CB11: EX-CB11

[40] Hint: Not Described (Outflow=Inflow)

Inflow Area = 0.453 ac, 50.83% Impervious, Inflow Depth = 4.45" for NOAA 25-yr event
Inflow = 2.46 cfs @ 12.13 hrs, Volume= 0.168 af
Outflow = 2.46 cfs @ 12.13 hrs, Volume= 0.168 af, Atten= 0%, Lag= 0.0 min
Routed to Reach DP-2 : PORTLAND STREET DRAINAGE

Routing by Stor-Ind+Trans method, Time Span= 0.00-72.00 hrs, dt= 0.05 hrs

Reach CB11: EX-CB11

Hydrograph

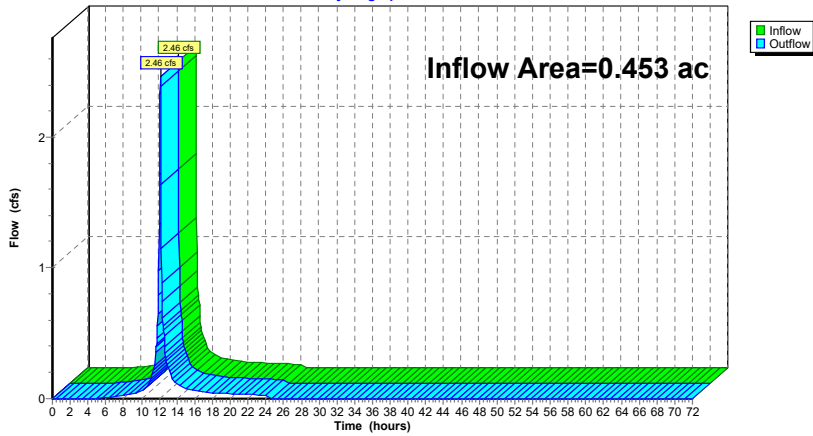

14850_Existing-Drainage-Areas

NOAA 24-hr C NOAA 25-yr Rainfall=6.04"

Prepared by {enter your company name here}

Printed 4/6/2022

HydroCAD® 10.10-7a s/n 00546 © 2021 HydroCAD Software Solutions LLC

Page 106

Summary for Reach CB2: EX-CB2

[40] Hint: Not Described (Outflow=Inflow)

Inflow Area = 0.519 ac, 71.14% Impervious, Inflow Depth = 5.00" for NOAA 25-yr event
Inflow = 3.05 cfs @ 12.13 hrs, Volume= 0.216 af
Outflow = 3.05 cfs @ 12.13 hrs, Volume= 0.216 af, Atten= 0%, Lag= 0.0 min
Routed to Reach DP-1 : French Rodney Blvd 14" Outfall

Routing by Stor-Ind+Trans method, Time Span= 0.00-72.00 hrs, dt= 0.05 hrs

Reach CB2: EX-CB2

Hydrograph

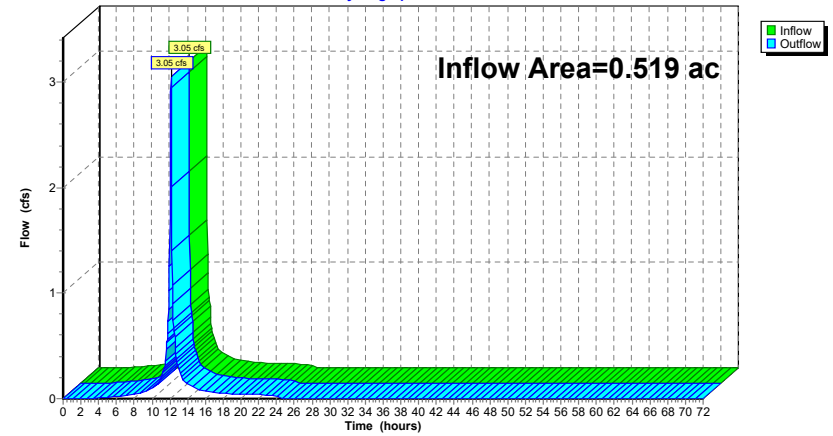

14850_Existing-Drainage-Areas

NOAA 24-hr C NOAA 25-yr Rainfall=6.04"

Prepared by {enter your company name here}

Printed 4/6/2022

HydroCAD® 10.10-7a s/n 00546 © 2021 HydroCAD Software Solutions LLC

Page 107

Summary for Reach CB3: EX-CB3

[40] Hint: Not Described (Outflow=Inflow)

Inflow Area = 0.265 ac, 100.00% Impervious, Inflow Depth = 5.80" for NOAA 25-yr event
Inflow = 1.66 cfs @ 12.13 hrs, Volume= 0.128 af
Outflow = 1.66 cfs @ 12.13 hrs, Volume= 0.128 af, Atten= 0%, Lag= 0.0 min
Routed to Reach DP-1 : French Rodney Blvd 14" Outfall

Routing by Stor-Ind+Trans method, Time Span= 0.00-72.00 hrs, dt= 0.05 hrs

Reach CB3: EX-CB3

Hydrograph

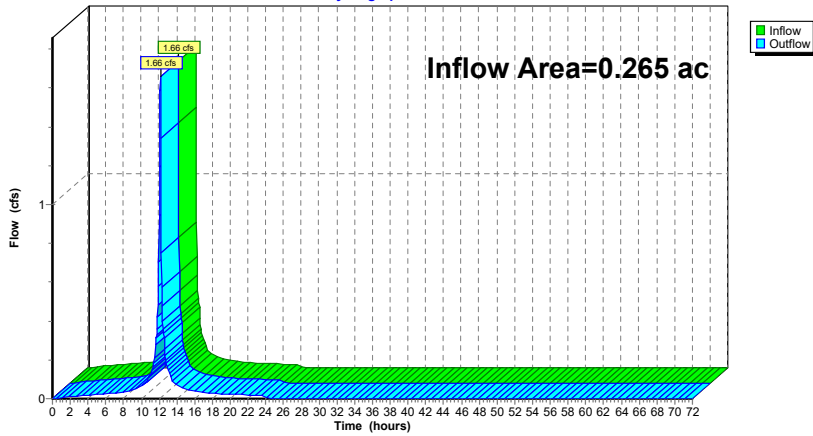

14850_Existing-Drainage-Areas

NOAA 24-hr C NOAA 25-yr Rainfall=6.04"

Prepared by {enter your company name here}

Printed 4/6/2022

HydroCAD® 10.10-7a s/n 00546 © 2021 HydroCAD Software Solutions LLC

Page 108

Summary for Reach CB4: EX-CB4

[40] Hint: Not Described (Outflow=Inflow)

Inflow Area = 0.450 ac, 58.17% Impervious, Inflow Depth = 4.66" for NOAA 25-yr event
Inflow = 2.53 cfs @ 12.13 hrs, Volume= 0.175 af
Outflow = 2.53 cfs @ 12.13 hrs, Volume= 0.175 af, Atten= 0%, Lag= 0.0 min
Routed to Reach DP-1 : French Rodney Blvd 14" Outfall

Routing by Stor-Ind+Trans method, Time Span= 0.00-72.00 hrs, dt= 0.05 hrs

Reach CB4: EX-CB4

Hydrograph

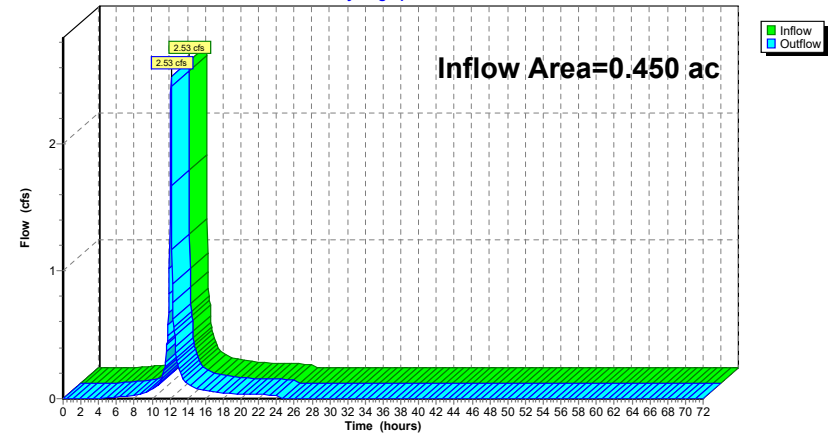

14850_Existing-Drainage-Areas

NOAA 24-hr C NOAA 25-yr Rainfall=6.04"

Prepared by {enter your company name here}

Printed 4/6/2022

HydroCAD® 10.10-7a s/n 00546 © 2021 HydroCAD Software Solutions LLC

Page 109

Summary for Reach CB5: EX-CB5

[40] Hint: Not Described (Outflow=Inflow)

Inflow Area = 0.527 ac, 57.51% Impervious, Inflow Depth = 4.66" for NOAA 25-yr event
Inflow = 2.97 cfs @ 12.13 hrs, Volume= 0.205 af
Outflow = 2.97 cfs @ 12.13 hrs, Volume= 0.205 af, Atten= 0%, Lag= 0.0 min
Routed to Reach DP-2 : PORTLAND STREET DRAINAGE

Routing by Stor-Ind+Trans method, Time Span= 0.00-72.00 hrs, dt= 0.05 hrs

Reach CB5: EX-CB5

Hydrograph

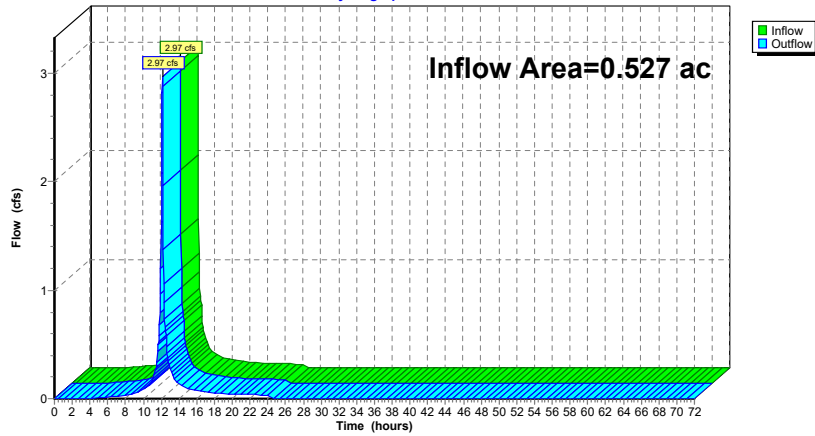

14850_Existing-Drainage-Areas

NOAA 24-hr C NOAA 25-yr Rainfall=6.04"

Prepared by {enter your company name here}

Printed 4/6/2022

HydroCAD® 10.10-7a s/n 00546 © 2021 HydroCAD Software Solutions LLC

Page 110

Summary for Reach CB6: EX-CB6

[40] Hint: Not Described (Outflow=Inflow)

Inflow Area = 0.793 ac, 93.00% Impervious, Inflow Depth = 5.57" for NOAA 25-yr event
Inflow = 4.90 cfs @ 12.13 hrs, Volume= 0.368 af
Outflow = 4.90 cfs @ 12.13 hrs, Volume= 0.368 af, Atten= 0%, Lag= 0.0 min
Routed to Reach DP-2 : PORTLAND STREET DRAINAGE

Routing by Stor-Ind+Trans method, Time Span= 0.00-72.00 hrs, dt= 0.05 hrs

Reach CB6: EX-CB6

Hydrograph

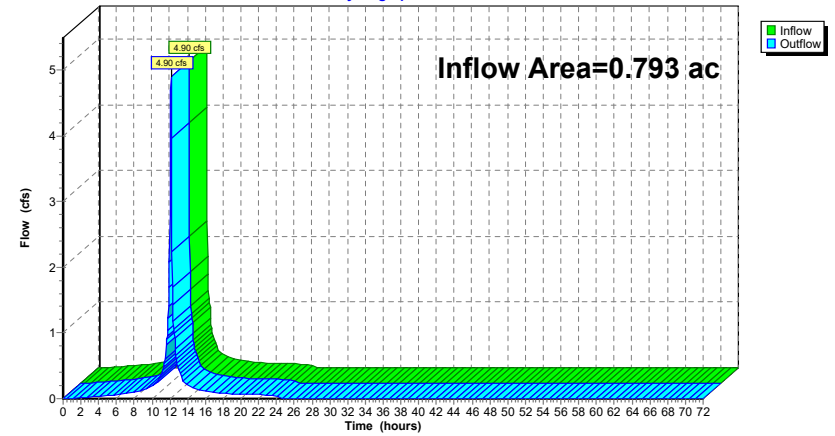

14850_Existing-Drainage-Areas

NOAA 24-hr C NOAA 25-yr Rainfall=6.04"

Prepared by {enter your company name here}

Printed 4/6/2022

HydroCAD® 10.10-7a s/n 00546 © 2021 HydroCAD Software Solutions LLC

Page 111

Summary for Reach CB7: EX-CB7

[40] Hint: Not Described (Outflow=Inflow)

Inflow Area = 0.578 ac, 51.84% Impervious, Inflow Depth = 4.45" for NOAA 25-yr event
Inflow = 3.14 cfs @ 12.13 hrs, Volume= 0.214 af
Outflow = 3.14 cfs @ 12.13 hrs, Volume= 0.214 af, Atten= 0%, Lag= 0.0 min
Routed to Reach DP-2 : PORTLAND STREET DRAINAGE

Routing by Stor-Ind+Trans method, Time Span= 0.00-72.00 hrs, dt= 0.05 hrs

Reach CB7: EX-CB7

Hydrograph

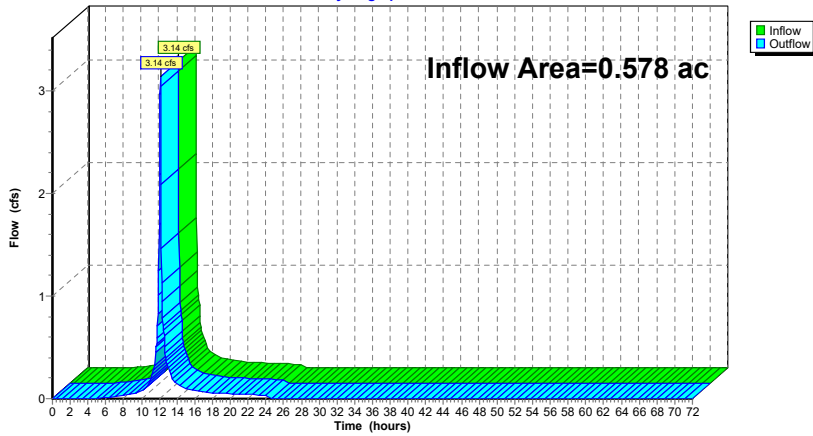

14850_Existing-Drainage-Areas

NOAA 24-hr C NOAA 25-yr Rainfall=6.04"

Prepared by {enter your company name here}

Printed 4/6/2022

HydroCAD® 10.10-7a s/n 00546 © 2021 HydroCAD Software Solutions LLC

Page 112

Summary for Reach CB8: EX-CB8

[40] Hint: Not Described (Outflow=Inflow)

Inflow Area = 3.367 ac, 50.27% Impervious, Inflow Depth = 4.47" for NOAA 25-yr event
Inflow = 18.36 cfs @ 12.13 hrs, Volume= 1.254 af
Outflow = 18.36 cfs @ 12.13 hrs, Volume= 1.254 af, Atten= 0%, Lag= 0.0 min
Routed to Reach DP-2 : PORTLAND STREET DRAINAGE

Routing by Stor-Ind+Trans method, Time Span= 0.00-72.00 hrs, dt= 0.05 hrs

Reach CB8: EX-CB8

Hydrograph

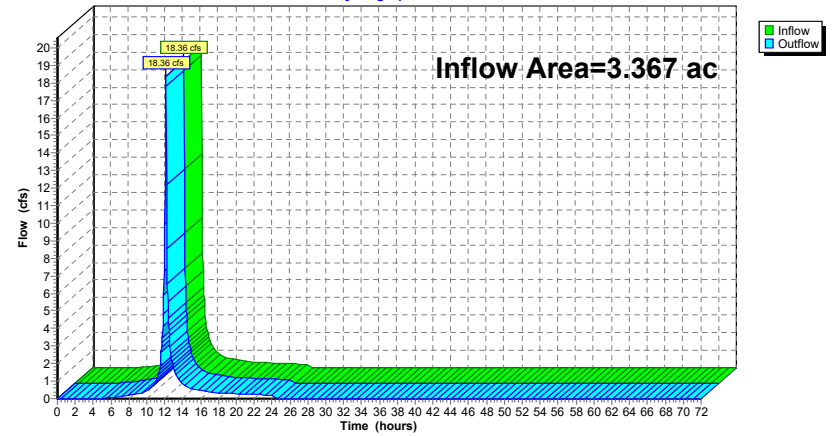

14850_Existing-Drainage-Areas

NOAA 24-hr C NOAA 25-yr Rainfall=6.04"

Prepared by {enter your company name here}

Printed 4/6/2022

HydroCAD® 10.10-7a s/n 00546 © 2021 HydroCAD Software Solutions LLC

Page 113

Summary for Reach CB9: EX CB-9

[40] Hint: Not Described (Outflow=Inflow)

Inflow Area = 0.829 ac, 94.03% Impervious, Inflow Depth = 5.68" for NOAA 25-yr event
Inflow = 5.15 cfs @ 12.13 hrs, Volume= 0.393 af
Outflow = 5.15 cfs @ 12.13 hrs, Volume= 0.393 af, Atten= 0%, Lag= 0.0 min
Routed to Reach DP-2 : PORTLAND STREET DRAINAGE

Routing by Stor-Ind+Trans method, Time Span= 0.00-72.00 hrs, dt= 0.05 hrs

Reach CB9: EX CB-9

Hydrograph

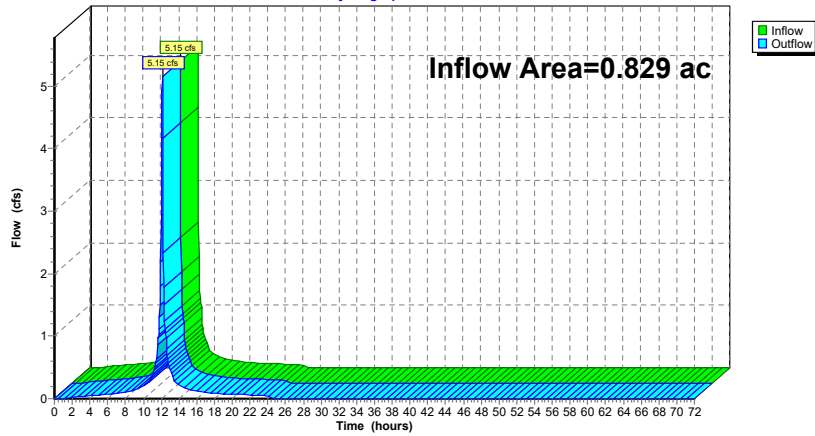

14850_Existing-Drainage-Areas

NOAA 24-hr C NOAA 25-yr Rainfall=6.04"

Prepared by {enter your company name here}

Printed 4/6/2022

HydroCAD® 10.10-7a s/n 00546 © 2021 HydroCAD Software Solutions LLC

Page 114

Summary for Reach DP-1: French Rodney Blvd 14" Outfall

[40] Hint: Not Described (Outflow=Inflow)

Inflow Area = 1.994 ac, 68.32% Impervious, Inflow Depth = 4.94" for NOAA 25-yr event
Inflow = 11.57 cfs @ 12.13 hrs, Volume= 0.822 af
Outflow = 11.57 cfs @ 12.13 hrs, Volume= 0.822 af, Atten= 0%, Lag= 0.0 min

Routing by Stor-Ind+Trans method, Time Span= 0.00-72.00 hrs, dt= 0.05 hrs

Reach DP-1: French Rodney Blvd 14" Outfall

Hydrograph

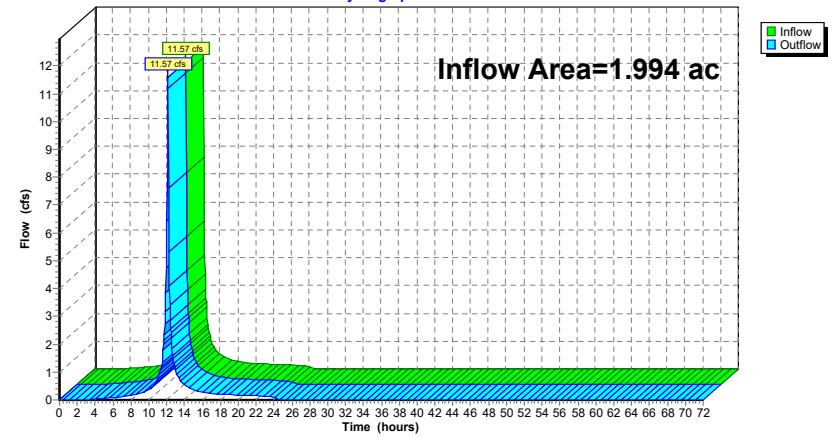

14850_Existing-Drainage-Areas

NOAA 24-hr C NOAA 25-yr Rainfall=6.04"

Prepared by {enter your company name here}

Printed 4/6/2022

HydroCAD® 10.10-7a s/n 00546 © 2021 HydroCAD Software Solutions LLC

Page 115

Summary for Reach DP-2: PORTLAND STREET DRAINAGE

[40] Hint: Not Described (Outflow=Inflow)

Inflow Area = 6.696 ac, 62.59% Impervious, Inflow Depth = 4.79" for NOAA 25-yr event
Inflow = 37.90 cfs @ 12.13 hrs, Volume= 2.673 af
Outflow = 37.90 cfs @ 12.13 hrs, Volume= 2.673 af, Atten= 0%, Lag= 0.0 min

Routing by Stor-Ind+Trans method, Time Span= 0.00-72.00 hrs, dt= 0.05 hrs

Reach DP-2: PORTLAND STREET DRAINAGE

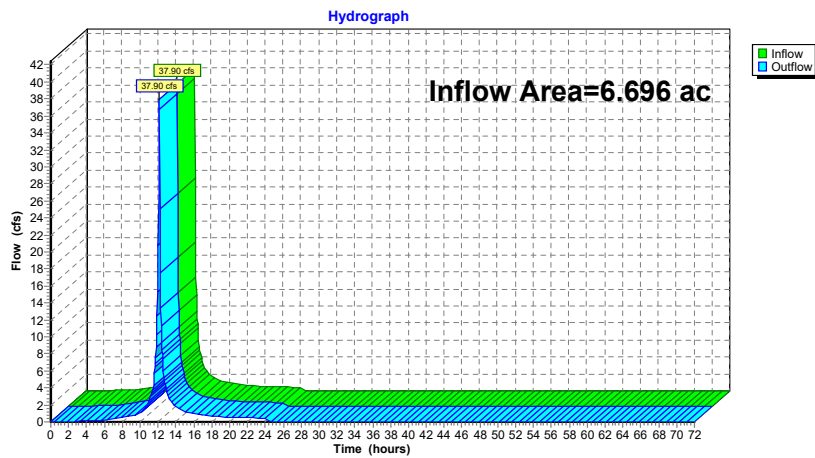

APPENDIX D

Post-Development Conditions – HydroCAD Calculations

14850_Proposed-Drainage-Areas_220609

Prepared by {enter your company name here}

HydroCAD® 10.10-7a s/n 00546 © 2021 HydroCAD Software Solutions LLC

Printed 6/16/2022

Page 2

Rainfall Events Listing (selected events)

Event#	Event Name	Storm Type	Curve	Mode	Duration (hours)	B/B	Depth (inches)	AMC
1	NOAA 10-yr	NOAA 24-hr	C	Default	24.00	1	5.02	2
2	NOAA 100-yr	NOAA 24-hr	C	Default	24.00	1	7.59	2
3	NOAA 2-yr	NOAA 24-hr	C	Default	24.00	1	3.40	2
4	NOAA 25-yr	NOAA 24-hr	C	Default	24.00	1	6.04	2

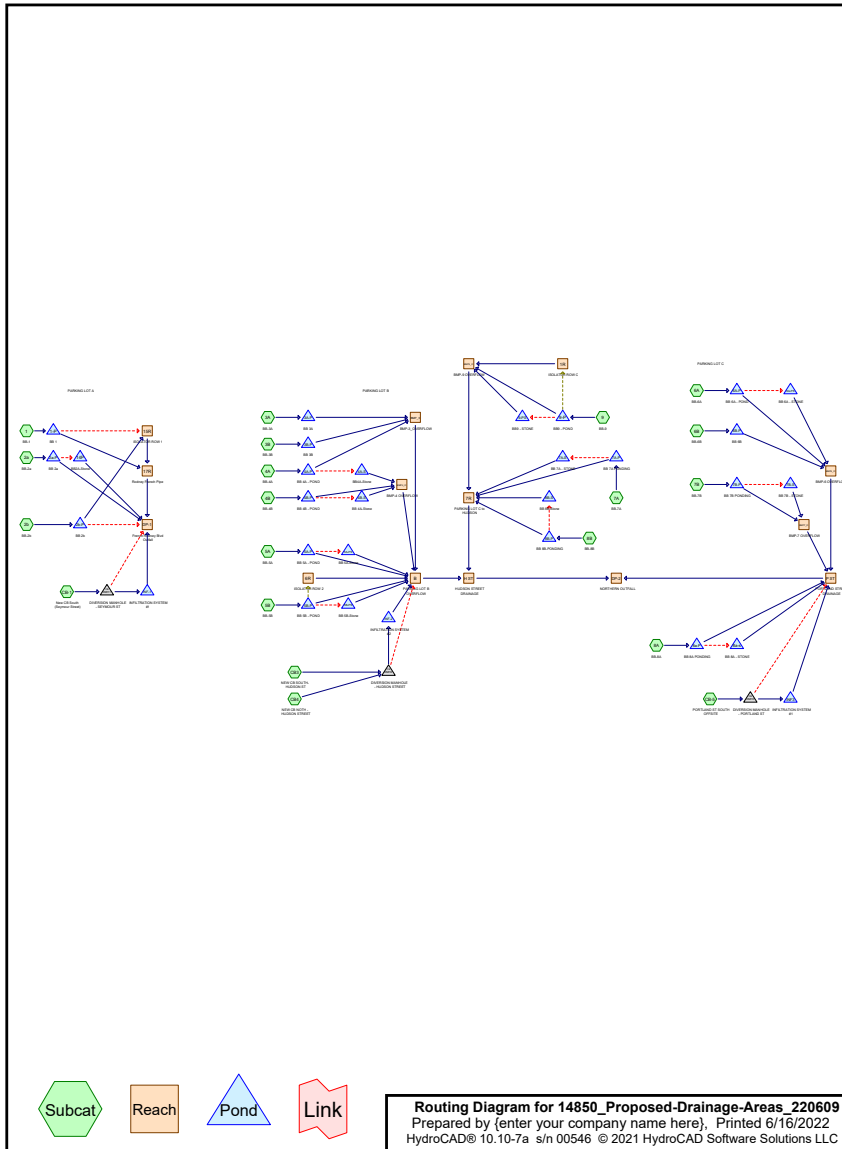

14850_Proposed-Drainage-Areas_220609

Prepared by {enter your company name here}

HydroCAD® 10.10-7a s/n 00546 © 2021 HydroCAD Software Solutions LLC

Printed 6/16/2022

Page 3

Area Listing (selected nodes)

Area (sq-ft)	CN	Description (subcatchment-numbers)
214,977	83	1/4 acre lots, 38% imp, HSG C (1, 2b, 3A, 5B, 6A, 6B, 9, CB-1, CB-5, CB3, CB4)
16,767	74	>75% Grass cover, Good, HSG C (1, 2a, 2b, 3A, 3B, 4A, 4B, 5A, 5B, 6A, 6B, 7A, 7B, 8A, 8B, 9)
107,061	98	Paved parking, HSG C (1, 2a, 2b, 3A, 3B, 4A, 4B, 5A, 5B, 6A, 6B, 7A, 7B, 8A, 8B, 9)
37,488	98	Roadway (CB-1, CB-5, CB3, CB4)
376,293	88	TOTAL AREA

14850_Proposed-Drainage-Areas_220609

NOAA 24-hr C NOAA 10-yr Rainfall=5.02"

Prepared by {enter your company name here}

HydroCAD® 10.10-7a s/n 00546 © 2021 HydroCAD Software Solutions LLC

Printed 6/16/2022

Page 4

Time span=0.00-72.00 hrs, dt=0.05 hrs, 1441 points
 Runoff by SCS TR-20 method, UH=SCS, Weighted-CN
 Reach routing by Stor-Ind+Trans method - Pond routing by Stor-Ind method

Pond 1-P: BB 1	Peak Elev=10.14' Storage=1,014 cf Inflow=3.85 cfs 11,278 cf Discarded=0.05 cfs 2,554 cf Primary=1.61 cfs 1,219 cf Secondary=2.06 cfs 7,505 cf Outflow=3.72 cfs 11,278 cf
Pond 2a-P: BB 2a	Peak Elev=9.38' Storage=261 cf Inflow=0.37 cfs 1,182 cf Primary=0.33 cfs 310 cf Secondary=0.03 cfs 873 cf Outflow=0.36 cfs 1,182 cf
Pond 2b-P: BB 2b	Peak Elev=8.36' Storage=167 cf Inflow=2.43 cfs 7,553 cf Primary=2.30 cfs 7,553 cf Secondary=0.00 cfs 0 cf Outflow=2.30 cfs 7,553 cf
Pond 3A-P: BB 3A	Peak Elev=11.07' Storage=449 cf Inflow=1.14 cfs 3,377 cf Discarded=0.02 cfs 1,314 cf Primary=1.07 cfs 2,063 cf Outflow=1.09 cfs 3,377 cf
Pond 3B-P: BB 3B	Peak Elev=12.89' Storage=254 cf Inflow=0.51 cfs 1,597 cf Discarded=0.01 cfs 799 cf Primary=0.49 cfs 798 cf Outflow=0.51 cfs 1,597 cf
Pond 4A-P: BB 4A - POND	Peak Elev=10.06' Storage=230 cf Inflow=0.56 cfs 1,792 cf Primary=0.51 cfs 683 cf Secondary=0.04 cfs 1,108 cf Outflow=0.54 cfs 1,792 cf
Pond 4A-S: BB4A-Stone	Peak Elev=7.12' Storage=26 cf Inflow=0.04 cfs 1,108 cf Outflow=0.04 cfs 1,091 cf
Pond 4B-P: BB 4B - POND	Peak Elev=11.03' Storage=131 cf Inflow=0.35 cfs 1,128 cf Primary=0.32 cfs 437 cf Secondary=0.02 cfs 690 cf Outflow=0.35 cfs 1,128 cf
Pond 4B-S: BB 4A-Stone	Peak Elev=7.85' Storage=15 cf Inflow=0.02 cfs 690 cf Outflow=0.02 cfs 680 cf
Pond 5A-P: BB 5A - POND	Peak Elev=9.43' Storage=369 cf Inflow=0.34 cfs 1,052 cf Primary=0.00 cfs 0 cf Secondary=0.04 cfs 1,052 cf Outflow=0.04 cfs 1,052 cf
Pond 5A-PS: BB 5A-Stone	Peak Elev=5.94' Storage=56 cf Inflow=0.04 cfs 1,052 cf Outflow=0.04 cfs 1,016 cf
Pond 5B-P: BB 5B - POND	Peak Elev=9.04' Storage=711 cf Inflow=3.81 cfs 11,589 cf Primary=1.59 cfs 931 cf Secondary=0.09 cfs 4,004 cf Tertiary=2.23 cfs 6,654 cf Outflow=3.92 cfs 11,589 cf
Pond 5B-PS: BB 5B-Stone	Peak Elev=5.46' Storage=96 cf Inflow=0.09 cfs 4,004 cf Outflow=0.09 cfs 3,953 cf
Pond 6A-P: BB 6A - POND	Peak Elev=11.00' Storage=420 cf Inflow=1.47 cfs 4,275 cf Primary=1.38 cfs 2,347 cf Secondary=0.05 cfs 1,928 cf Outflow=1.43 cfs 4,275 cf
Pond 6A-PS: BB 6A - STONE	Peak Elev=7.39' Storage=34 cf Inflow=0.05 cfs 1,928 cf Outflow=0.05 cfs 1,906 cf
Pond 6B-P: BB 6B	Peak Elev=12.08' Storage=380 cf Inflow=0.73 cfs 2,283 cf Discarded=0.02 cfs 1,071 cf Primary=0.69 cfs 1,212 cf Outflow=0.71 cfs 2,283 cf

14850_Proposed-Drainage-Areas_220609

NOAA 24-hr C NOAA 10-yr Rainfall=5.02"

Prepared by {enter your company name here}

Printed 6/16/2022

HydroCAD@ 10.10-7a s/n 00546 © 2021 HydroCAD Software Solutions LLC

Page 5

Pond 7A-P: BB 7A PONDING Peak Elev=9.98' Storage=148 cf Inflow=0.37 cfs 1,171 cf
 Primary=0.34 cfs 465 cf Secondary=0.02 cfs 706 cf Outflow=0.36 cfs 1,171 cf

Pond 7A-S: BB 7A - STONE Peak Elev=5.19' Storage=4 cf Inflow=0.02 cfs 706 cf
 Outflow=0.02 cfs 706 cf

Pond 7B-P: BB 7B PONDING Peak Elev=10.71' Storage=274 cf Inflow=0.57 cfs 1,828 cf
 Primary=0.52 cfs 676 cf Secondary=0.03 cfs 1,153 cf Outflow=0.56 cfs 1,828 cf

Pond 7B-S: BB 7B - STONE Peak Elev=7.62' Storage=17 cf Inflow=0.03 cfs 1,153 cf
 Outflow=0.03 cfs 1,141 cf

Pond 8a-P: BB 8A PONDING Peak Elev=9.09' Storage=285 cf Inflow=0.45 cfs 1,398 cf
 Primary=0.38 cfs 357 cf Secondary=0.04 cfs 1,041 cf Outflow=0.42 cfs 1,398 cf

Pond 8a-s: BB 8A - STONE Peak Elev=5.63' Storage=30 cf Inflow=0.04 cfs 1,041 cf
 Outflow=0.04 cfs 1,023 cf

Pond 8B-P: BB 8B-PONDING Peak Elev=9.72' Storage=255 cf Inflow=0.65 cfs 2,071 cf
 Primary=0.60 cfs 805 cf Secondary=0.04 cfs 1,266 cf Outflow=0.64 cfs 2,071 cf

Pond 8B-S: BB 8B-Stone Peak Elev=6.33' Storage=39 cf Inflow=0.04 cfs 1,266 cf
 Outflow=0.04 cfs 1,239 cf

Pond 9-P: BB9 - POND Peak Elev=8.93' Storage=430 cf Inflow=3.30 cfs 10,153 cf
 Primary=0.67 cfs 245 cf Secondary=0.05 cfs 2,215 cf Tertiary=2.51 cfs 7,693 cf Outflow=3.22 cfs 10,153 cf

Pond 9-PS: BB9 - STONE Peak Elev=5.40' Storage=23 cf Inflow=0.05 cfs 2,215 cf
 Outflow=0.05 cfs 2,200 cf

Pond 14P: BB2A-Stone Peak Elev=5.61' Storage=6 cf Inflow=0.03 cfs 873 cf
 Outflow=0.03 cfs 873 cf

Pond DMH1: DIVERSION MANHOLE - SEYMOUR ST Peak Elev=9.81' Inflow=2.03 cfs 6,018 cf
 Primary=0.71 cfs 4,632 cf Secondary=1.32 cfs 1,386 cf Outflow=2.03 cfs 6,018 cf

Pond DMH2: DIVERSION MANHOLE - HUDSON STREET Peak Elev=20.37' Inflow=14.20 cfs 41,627 cf
 Primary=2.93 cfs 23,559 cf Secondary=11.27 cfs 18,068 cf Outflow=14.20 cfs 41,627 cf

Pond DMH3: DIVERSION MANHOLE - PORTLAND ST Peak Elev=11.73' Inflow=1.96 cfs 5,735 cf
 Primary=1.06 cfs 4,862 cf Secondary=0.90 cfs 872 cf Outflow=1.96 cfs 5,735 cf

Pond INF-1: INFILTRATIONS SYSTEM #1 Peak Elev=9.44' Storage=1,658 cf Inflow=0.71 cfs 4,632 cf
 Discarded=0.08 cfs 4,195 cf Primary=0.15 cfs 437 cf Outflow=0.23 cfs 4,632 cf

Pond INF-2: INFILTRATIONS SYSTEM #2 Peak Elev=9.80' Storage=3,428 cf Inflow=2.93 cfs 23,559 cf
 Discarded=0.12 cfs 9,228 cf Primary=2.66 cfs 14,332 cf Outflow=2.77 cfs 23,559 cf

Pond INF3: INFILTRATIONS SYSTEM #1 Peak Elev=9.66' Storage=991 cf Inflow=1.06 cfs 4,862 cf
 Discarded=0.05 cfs 2,902 cf Primary=1.00 cfs 1,960 cf Outflow=1.05 cfs 4,862 cf

14850_Proposed-Drainage-Areas_220609

NOAA 24-hr C NOAA 10-yr Rainfall=5.02"

Prepared by {enter your company name here}

Printed 6/16/2022

HydroCAD@ 10.10-7a s/n 00546 © 2021 HydroCAD Software Solutions LLC

Page 6

Summary for Pond 1-P: BB 1

Inflow Area = 38,826 sf, 51.66% Impervious, Inflow Depth = 3.49" for NOAA 10-yr event
 Inflow = 3.85 cfs @ 12.13 hrs, Volume= 11,278 cf
 Outflow = 3.72 cfs @ 12.15 hrs, Volume= 11,278 cf, Atten= 3%, Lag= 1.1 min
 Discarded = 0.05 cfs @ 12.15 hrs, Volume= 2,554 cf
 Primary = 1.61 cfs @ 12.15 hrs, Volume= 1,219 cf
 Routed to Reach 17R : Rodney French Pipe
 Secondary = 2.06 cfs @ 12.15 hrs, Volume= 7,505 cf
 Routed to Reach 15R : ISOLATOR ROW 1

Routing by Stor-Ind method, Time Span= 0.00-72.00 hrs, dt= 0.05 hrs
 Peak Elev= 10.14' @ 12.15 hrs Surf.Area= 1,748 sf Storage= 1,014 cf

Plug-Flow detention time= 53.1 min calculated for 11,270 cf (100% of inflow)
 Center-of-Mass det. time= 53.4 min (860.5 - 807.1)

Volume	Invert	Avail.Storage	Storage Description
#1	9.20'	1,114 cf	Custom Stage Data (Prismatic) Listed below (Recalc)
Elevation (feet)	Surf.Area (sq-ft)	Inc.Store (cubic-feet)	Cum.Store (cubic-feet)
9.20	490	0	0
9.50	800	194	194
10.20	1,830	920	1,114

Device	Routing	Invert	Outlet Devices
#1	Primary	8.00'	12.0" Round Culvert L= 10.0' CPP, square edge headwall, Ke= 0.500 Inlet / Outlet Invert= 8.00' / 7.90' S= 0.0100 '/ Cc= 0.900 n= 0.013, Flow Area= 0.79 sf
#2	Discarded	9.20'	1.020 in/hr Exfiltration over Surface area Conductivity to Groundwater Elevation = 6.00'
#3	Device 1	10.00'	24inch-Dome Grate Capacity X 2.00
#4	Secondary	9.83'	15inch-Dome Grate Capacity

Discarded OutFlow Max=0.05 cfs @ 12.15 hrs HW=10.14' (Free Discharge)
 ↳2=Exfiltration (Controls 0.05 cfs)

Primary OutFlow Max=1.59 cfs @ 12.15 hrs HW=10.14' (Free Discharge)
 ↳1=Culvert (Passes 1.59 cfs of 4.85 cfs potential flow)
 ↳3=24inch-Dome Grate Capacity (Custom Controls 1.59 cfs)

Secondary OutFlow Max=2.05 cfs @ 12.15 hrs HW=10.14' (Free Discharge)
 ↳4=15inch-Dome Grate Capacity (Custom Controls 2.05 cfs)

14850_Proposed-Drainage-Areas_220609

NOAA 24-hr C NOAA 10-yr Rainfall=5.02"

Prepared by {enter your company name here}

Printed 6/16/2022

HydroCAD® 10.10-7a s/n 00546 © 2021 HydroCAD Software Solutions LLC

Page 7

Summary for Pond 2a-P: BB 2a

Inflow Area = 3,116 sf, 92.62% Impervious, Inflow Depth = 4.55" for NOAA 10-yr event
 Inflow = 0.37 cfs @ 12.13 hrs, Volume= 1,182 cf
 Outflow = 0.36 cfs @ 12.15 hrs, Volume= 1,182 cf, Atten= 3%, Lag= 1.3 min
 Primary = 0.33 cfs @ 12.15 hrs, Volume= 310 cf
 Routed to Reach DP-1 : French Rodney Blvd Outfall
 Secondary = 0.03 cfs @ 12.15 hrs, Volume= 873 cf
 Routed to Pond 14P : BB2A-Stone

Routing by Stor-Ind method, Time Span= 0.00-72.00 hrs, dt= 0.05 hrs
 Peak Elev= 9.38' @ 12.15 hrs Surf.Area= 416 sf Storage= 261 cf

Plug-Flow detention time= 61.2 min calculated for 1,181 cf (100% of inflow)
 Center-of-Mass det. time= 61.2 min (824.9 - 763.7)

Volume	Invert	Avail.Storage	Storage Description
#1	8.50'	462 cf	Custom Stage Data (Prismatic) Listed below (Recalc)
Elevation (feet)	Surf.Area (sq-ft)	Inc.Store (cubic-feet)	Cum.Store (cubic-feet)
8.50	180	0	0
9.80	530	462	462

Device	Routing	Invert	Outlet Devices
#1	Primary	7.80'	10.0" Round Culvert L= 10.0' CPP, square edge headwall, Ke= 0.500 Inlet / Outlet Invert= 7.80' / 7.70' S= 0.0100 '/ Cc= 0.900 n= 0.013, Flow Area= 0.55 sf
#2	Device 1	9.30'	24inch-Dome Grate Capacity
#3	Secondary	8.50'	2.410 in/hr Exfiltration over Surface area Conductivity to Groundwater Elevation = 4.60'

Primary OutFlow Max=0.33 cfs @ 12.15 hrs HW=9.38' (Free Discharge)

↑1=Culvert (Passes 0.33 cfs of 2.83 cfs potential flow)

↑2=24inch-Dome Grate Capacity (Custom Controls 0.33 cfs)

Secondary OutFlow Max=0.03 cfs @ 12.15 hrs HW=9.38' (Free Discharge)

↑3=Exfiltration (Controls 0.03 cfs)

14850_Proposed-Drainage-Areas_220609

NOAA 24-hr C NOAA 10-yr Rainfall=5.02"

Prepared by {enter your company name here}

Printed 6/16/2022

HydroCAD® 10.10-7a s/n 00546 © 2021 HydroCAD Software Solutions LLC

Page 8

Summary for Pond 2b-P: BB 2b

Inflow Area = 21,490 sf, 80.50% Impervious, Inflow Depth = 4.22" for NOAA 10-yr event
 Inflow = 2.43 cfs @ 12.13 hrs, Volume= 7,553 cf
 Outflow = 2.30 cfs @ 12.15 hrs, Volume= 7,553 cf, Atten= 6%, Lag= 1.2 min
 Primary = 2.30 cfs @ 12.15 hrs, Volume= 7,553 cf
 Routed to Reach 15R : ISOLATOR ROW 1
 Secondary = 0.00 cfs @ 0.00 hrs, Volume= 0 cf
 Routed to Reach DP-1 : French Rodney Blvd Outfall

Routing by Stor-Ind method, Time Span= 0.00-72.00 hrs, dt= 0.05 hrs
 Peak Elev= 8.36' @ 12.15 hrs Surf.Area= 603 sf Storage= 167 cf

Plug-Flow detention time= 1.7 min calculated for 7,553 cf (100% of inflow)
 Center-of-Mass det. time= 1.7 min (781.9 - 780.2)

Volume	Invert	Avail.Storage	Storage Description
#1	8.00'	710 cf	Custom Stage Data (Prismatic) Listed below (Recalc)
Elevation (feet)	Surf.Area (sq-ft)	Inc.Store (cubic-feet)	Cum.Store (cubic-feet)
8.00	320	0	0
9.00	1,100	710	710

Device	Routing	Invert	Outlet Devices
#1	Secondary	7.00'	12.0" Round Culvert L= 10.0' CPP, square edge headwall, Ke= 0.500 Inlet / Outlet Invert= 7.00' / 6.90' S= 0.0100 '/ Cc= 0.900 n= 0.013, Flow Area= 0.79 sf
#2	Device 1	8.50'	24inch-Dome Grate Capacity X 2.00
#3	Primary	8.00'	15inch-Dome Grate Capacity

Primary OutFlow Max=2.29 cfs @ 12.15 hrs HW=8.36' (Free Discharge)

↑3=15inch-Dome Grate Capacity (Custom Controls 2.29 cfs)

Secondary OutFlow Max=0.00 cfs @ 0.00 hrs HW=8.00' (Free Discharge)

↑1=Culvert (Passes 0.00 cfs of 2.27 cfs potential flow)

↑2=24inch-Dome Grate Capacity (Controls 0.00 cfs)

14850_Proposed-Drainage-Areas_220609

NOAA 24-hr C NOAA 10-yr Rainfall=5.02"

Prepared by {enter your company name here}

Printed 6/16/2022

HydroCAD® 10.10-7a s/n 00546 © 2021 HydroCAD Software Solutions LLC

Page 9

Summary for Pond 3A-P: BB 3A

Inflow Area = 10,987 sf, 58.16% Impervious, Inflow Depth = 3.69" for NOAA 10-yr event
 Inflow = 1.14 cfs @ 12.13 hrs, Volume= 3,377 cf
 Outflow = 1.09 cfs @ 12.15 hrs, Volume= 3,377 cf, Atten= 4%, Lag= 1.3 min
 Discarded = 0.02 cfs @ 12.15 hrs, Volume= 1,314 cf
 Primary = 1.07 cfs @ 12.15 hrs, Volume= 2,063 cf
 Routed to Reach BMP_3 : BMP-3_OVERFLOW

Routing by Stor-Ind method, Time Span= 0.00-72.00 hrs, dt= 0.05 hrs
 Peak Elev= 11.07' @ 12.15 hrs Surf.Area= 894 sf Storage= 449 cf

Plug-Flow detention time= 84.5 min calculated for 3,374 cf (100% of inflow)
 Center-of-Mass det. time= 84.7 min (885.1 - 800.4)

Volume	Invert	Avail.Storage	Storage Description
#1	10.25'	622 cf	Custom Stage Data (Prismatic) Listed below (Recalc)
Elevation (feet)	Surf.Area (sq-ft)	Inc.Store (cubic-feet)	Cum.Store (cubic-feet)
10.25	271	0	0
10.45	350	62	62
11.25	1,050	560	622

Device	Routing	Invert	Outlet Devices
#1	Primary	9.30'	10.0" Round Culvert L= 10.0' CPP, square edge headwall, Ke= 0.500 Inlet / Outlet Invert= 9.30' / 9.20' S= 0.0100 '/ Cc= 0.900 n= 0.013, Flow Area= 0.55 sf
#2	Discarded	10.25'	1.020 in/hr Exfiltration over Surface area Conductivity to Groundwater Elevation = 7.30'
#3	Primary	11.15'	5.0' long Sharp-Crested Rectangular Weir 2 End Contraction(s)
#4	Device 1	10.90'	24inch-Dome Grate Capacity

Discarded OutFlow Max=0.02 cfs @ 12.15 hrs HW=11.07' (Free Discharge)
 ↳ **2=Exfiltration** (Controls 0.02 cfs)

Primary OutFlow Max=1.07 cfs @ 12.15 hrs HW=11.07' (Free Discharge)
 ↳ **1=Culvert** (Passes 1.07 cfs of 3.06 cfs potential flow)
 ↳ **4=24inch-Dome Grate Capacity** (Custom Controls 1.07 cfs)
 ↳ **3=Sharp-Crested Rectangular Weir** (Controls 0.00 cfs)

14850_Proposed-Drainage-Areas_220609

NOAA 24-hr C NOAA 10-yr Rainfall=5.02"

Prepared by {enter your company name here}

Printed 6/16/2022

HydroCAD® 10.10-7a s/n 00546 © 2021 HydroCAD Software Solutions LLC

Page 10

Summary for Pond 3B-P: BB 3B

Inflow Area = 4,545 sf, 77.34% Impervious, Inflow Depth = 4.22" for NOAA 10-yr event
 Inflow = 0.51 cfs @ 12.13 hrs, Volume= 1,597 cf
 Outflow = 0.51 cfs @ 12.14 hrs, Volume= 1,597 cf, Atten= 1%, Lag= 1.0 min
 Discarded = 0.01 cfs @ 12.14 hrs, Volume= 799 cf
 Primary = 0.49 cfs @ 12.14 hrs, Volume= 798 cf
 Routed to Reach BMP_3 : BMP-3_OVERFLOW

Routing by Stor-Ind method, Time Span= 0.00-72.00 hrs, dt= 0.05 hrs
 Peak Elev= 12.89' @ 12.14 hrs Surf.Area= 562 sf Storage= 254 cf

Plug-Flow detention time= 96.8 min calculated for 1,597 cf (100% of inflow)
 Center-of-Mass det. time= 96.7 min (876.9 - 780.2)

Volume	Invert	Avail.Storage	Storage Description
#1	12.20'	263 cf	Custom Stage Data (Prismatic) Listed below (Recalc)
Elevation (feet)	Surf.Area (sq-ft)	Inc.Store (cubic-feet)	Cum.Store (cubic-feet)
12.20	180	0	0
12.90	570	263	263

Device	Routing	Invert	Outlet Devices
#1	Primary	10.70'	10.0" Round Culvert L= 10.0' CPP, square edge headwall, Ke= 0.500 Inlet / Outlet Invert= 10.70' / 10.60' S= 0.0100 '/ Cc= 0.900 n= 0.013, Flow Area= 0.55 sf
#2	Discarded	12.20'	1.020 in/hr Exfiltration over Surface area Conductivity to Groundwater Elevation = 8.70'
#3	Device 1	12.80'	24inch-Dome Grate Capacity
#4	Primary	12.85'	5.0' long Sharp-Crested Rectangular Weir 2 End Contraction(s)

Discarded OutFlow Max=0.01 cfs @ 12.14 hrs HW=12.88' (Free Discharge)
 ↳ **2=Exfiltration** (Controls 0.01 cfs)

Primary OutFlow Max=0.48 cfs @ 12.14 hrs HW=12.88' (Free Discharge)
 ↳ **1=Culvert** (Passes 0.37 cfs of 3.49 cfs potential flow)
 ↳ **3=24inch-Dome Grate Capacity** (Custom Controls 0.37 cfs)
 ↳ **4=Sharp-Crested Rectangular Weir** (Weir Controls 0.11 cfs @ 0.61 fps)

14850_Proposed-Drainage-Areas_220609

NOAA 24-hr C NOAA 10-yr Rainfall=5.02"

Prepared by {enter your company name here}

Printed 6/16/2022

HydroCAD® 10.10-7a s/n 00546 © 2021 HydroCAD Software Solutions LLC

Page 11

Summary for Pond 4A-P: BB 4A - POND

Inflow Area = 4,843 sf, 86.37% Impervious, Inflow Depth = 4.44" for NOAA 10-yr event
 Inflow = 0.56 cfs @ 12.13 hrs, Volume= 1,792 cf
 Outflow = 0.54 cfs @ 12.15 hrs, Volume= 1,792 cf, Atten= 4%, Lag= 1.3 min
 Primary = 0.51 cfs @ 12.15 hrs, Volume= 683 cf
 Routed to Reach BMP_3 : BMP-3_OVERFLOW
 Secondary = 0.04 cfs @ 12.15 hrs, Volume= 1,108 cf
 Routed to Pond 4A-S : BB4A-Stone

Routing by Stor-Ind method, Time Span= 0.00-72.00 hrs, dt= 0.05 hrs
 Peak Elev= 10.06' @ 12.15 hrs Surf.Area= 579 sf Storage= 230 cf

Plug-Flow detention time= 30.6 min calculated for 1,790 cf (100% of inflow)
 Center-of-Mass det. time= 30.6 min (800.4 - 769.8)

Volume	Invert	Avail.Storage	Storage Description
#1	9.50'	320 cf	Custom Stage Data (Prismatic) Listed below (Recalc)
Elevation (feet)	Surf.Area (sq-ft)	Inc.Store (cubic-feet)	Cum.Store (cubic-feet)
9.50	250	0	0
10.20	664	320	320

Device	Routing	Invert	Outlet Devices
#1	Primary	8.00'	12.0" Round Culvert L= 10.0' CPP, square edge headwall, Ke= 0.500 Inlet / Outlet Invert= 8.00' / 7.90' S= 0.0100 '/ S= 0.0100 ' Cc= 0.900 n= 0.013, Flow Area= 0.79 sf
#2	Secondary	9.50'	2.410 in/hr Exfiltration over Surface area Conductivity to Groundwater Elevation = 6.00'
#3	Primary	10.10'	5.0' long Sharp-Crested Rectangular Weir 2 End Contraction(s)
#4	Device 1	9.95'	24inchDome Grate Capacity Head (feet) 0.00 0.05 0.10 0.15 0.20 0.25 0.30 0.35 0.40 0.45 0.50 0.55 0.60 0.65 0.70 0.75 0.80 0.85 0.90 0.95 1.00 1.05 1.10 Disch. (cfs) 0.000 0.180 0.460 0.850 1.360 1.830 2.420 3.100 3.600 3.800 4.000 4.200 4.380 4.600 4.750 4.900 5.100 5.200 5.350 5.450 5.650 5.800 5.950

Primary OutFlow Max=0.50 cfs @ 12.15 hrs HW=10.06' (Free Discharge)
 1=Culvert (Passes 0.50 cfs of 4.72 cfs potential flow)
 4=24inchDome Grate Capacity (Custom Controls 0.50 cfs)
 3=Sharp-Crested Rectangular Weir (Controls 0.00 cfs)

Secondary OutFlow Max=0.04 cfs @ 12.15 hrs HW=10.06' (Free Discharge)
 2=Exfiltration (Controls 0.04 cfs)

14850_Proposed-Drainage-Areas_220609

NOAA 24-hr C NOAA 10-yr Rainfall=5.02"

Prepared by {enter your company name here}

Printed 6/16/2022

HydroCAD® 10.10-7a s/n 00546 © 2021 HydroCAD Software Solutions LLC

Page 12

Summary for Pond 4A-S: BB4A-Stone

Inflow = 0.04 cfs @ 12.15 hrs, Volume= 1,108 cf
 Outflow = 0.04 cfs @ 12.18 hrs, Volume= 1,091 cf, Atten= 1%, Lag= 2.0 min
 Primary = 0.04 cfs @ 12.18 hrs, Volume= 1,091 cf
 Routed to Reach BMP4_O : BMP-4_OVERFLOW

Routing by Stor-Ind method, Time Span= 0.00-72.00 hrs, dt= 0.05 hrs
 Peak Elev= 7.12' @ 12.18 hrs Surf.Area= 230 sf Storage= 26 cf

Plug-Flow detention time= 25.0 min calculated for 1,091 cf (98% of inflow)
 Center-of-Mass det. time= 15.4 min (856.2 - 840.7)

Volume	Invert	Avail.Storage	Storage Description
#1	6.75'	138 cf	Custom Stage Data (Prismatic) Listed below (Recalc) 460 cf Overall x 30.0% Voids

Elevation (feet)	Surf.Area (sq-ft)	Inc.Store (cubic-feet)	Cum.Store (cubic-feet)
6.75	230	0	0
8.75	230	460	460

Device	Routing	Invert	Outlet Devices
#1	Primary	7.00'	4.0" Vert. Orifice/Grate C= 0.600 Limited to weir flow at low heads

Primary OutFlow Max=0.04 cfs @ 12.18 hrs HW=7.12' (Free Discharge)
 1=Orifice/Grate (Orifice Controls 0.04 cfs @ 1.20 fps)

14850_Proposed-Drainage-Areas_220609

NOAA 24-hr C NOAA 10-yr Rainfall=5.02"

Prepared by {enter your company name here}

Printed 6/16/2022

HydroCAD® 10.10-7a s/n 00546 © 2021 HydroCAD Software Solutions LLC

Page 13

Summary for Pond 4B-P: BB 4B - POND

Inflow Area = 3,048 sf, 86.09% Impervious, Inflow Depth = 4.44" for NOAA 10-yr event
 Inflow = 0.35 cfs @ 12.13 hrs, Volume= 1,128 cf
 Outflow = 0.35 cfs @ 12.14 hrs, Volume= 1,128 cf, Atten= 2%, Lag= 1.0 min
 Primary = 0.32 cfs @ 12.14 hrs, Volume= 437 cf
 Routed to Reach BMP4_O : BMP-4 OVERFLOW
 Secondary = 0.02 cfs @ 12.14 hrs, Volume= 690 cf
 Routed to Pond 4B-S : BB 4A-Stone

Routing by Stor-Ind method, Time Span= 0.00-72.00 hrs, dt= 0.05 hrs
 Peak Elev= 11.03' @ 12.14 hrs Surf.Area= 354 sf Storage= 131 cf

Plug-Flow detention time= 29.9 min calculated for 1,128 cf (100% of inflow)
 Center-of-Mass det. time= 29.9 min (799.6 - 769.8)

Volume	Invert	Avail.Storage	Storage Description
#1	10.50'	199 cf	Custom Stage Data (Prismatic) Listed below (Recalc)
Elevation (feet)	Surf.Area (sq-ft)	Inc.Store (cubic-feet)	Cum.Store (cubic-feet)
10.50	144	0	0
11.20	424	199	199

Device	Routing	Invert	Outlet Devices
#1	Primary	9.00'	12.0" Round Culvert L= 10.0' CPP, square edge headwall, Ke= 0.500 Inlet / Outlet Invert= 9.00' / 8.90' S= 0.0100 '/ Cc= 0.900 n= 0.013, Flow Area= 0.79 sf
#2	Secondary	10.50'	2.410 in/hr Exfiltration over Surface area Conductivity to Groundwater Elevation = 7.00'
#3	Primary	11.10'	5.0' long Sharp-Crested Rectangular Weir 2 End Contraction(s)
#4	Device 1	10.95'	24inch-Dome Grate Capacity

Primary OutFlow Max=0.32 cfs @ 12.14 hrs HW=11.02' (Free Discharge)

1=Culvert (Passes 0.32 cfs of 4.67 cfs potential flow)

4=24inch-Dome Grate Capacity (Custom Controls 0.32 cfs)

3=Sharp-Crested Rectangular Weir (Controls 0.00 cfs)

Secondary OutFlow Max=0.02 cfs @ 12.14 hrs HW=11.02' (Free Discharge)

2=Exfiltration (Controls 0.02 cfs)

14850_Proposed-Drainage-Areas_220609

NOAA 24-hr C NOAA 10-yr Rainfall=5.02"

Prepared by {enter your company name here}

Printed 6/16/2022

HydroCAD® 10.10-7a s/n 00546 © 2021 HydroCAD Software Solutions LLC

Page 14

Summary for Pond 4B-S: BB 4A-Stone

Inflow = 0.02 cfs @ 12.14 hrs, Volume= 690 cf
 Outflow = 0.02 cfs @ 12.17 hrs, Volume= 680 cf, Atten= 0%, Lag= 1.4 min
 Primary = 0.02 cfs @ 12.17 hrs, Volume= 680 cf
 Routed to Reach BMP4_O : BMP-4 OVERFLOW

Routing by Stor-Ind method, Time Span= 0.00-72.00 hrs, dt= 0.05 hrs
 Peak Elev= 7.85' @ 12.17 hrs Surf.Area= 145 sf Storage= 15 cf

Plug-Flow detention time= 23.9 min calculated for 680 cf (98% of inflow)
 Center-of-Mass det. time= 14.3 min (855.6 - 841.3)

Volume	Invert	Avail.Storage	Storage Description
#1	7.50'	87 cf	Custom Stage Data (Prismatic) Listed below (Recalc) 290 cf Overall x 30.0% Voids

Elevation (feet)	Surf.Area (sq-ft)	Inc.Store (cubic-feet)	Cum.Store (cubic-feet)
7.50	145	0	0
9.50	145	290	290

Device	Routing	Invert	Outlet Devices
#1	Primary	7.75'	4.0" Vert. Orifice/Grate C= 0.600 Limited to weir flow at low heads

Primary OutFlow Max=0.02 cfs @ 12.17 hrs HW=7.85' (Free Discharge)

1=Orifice/Grate (Orifice Controls 0.02 cfs @ 1.05 fps)

14850_Proposed-Drainage-Areas_220609

NOAA 24-hr C NOAA 10-yr Rainfall=5.02"

Prepared by {enter your company name here}

Printed 6/16/2022

HydroCAD® 10.10-7a s/n 00546 © 2021 HydroCAD Software Solutions LLC

Page 15

Summary for Pond 5A-P: BB 5A - POND

Inflow Area = 3,072 sf, 73.44% Impervious, Inflow Depth = 4.11" for NOAA 10-yr event
 Inflow = 0.34 cfs @ 12.13 hrs, Volume= 1,052 cf
 Outflow = 0.04 cfs @ 12.69 hrs, Volume= 1,052 cf, Atten= 87%, Lag= 33.5 min
 Primary = 0.00 cfs @ 0.00 hrs, Volume= 0 cf
 Routed to Reach B : PARKING LOT B OVERFLOW
 Secondary = 0.04 cfs @ 12.69 hrs, Volume= 1,052 cf
 Routed to Pond 5A-PS : BB 5A-Stone

Routing by Stor-Ind method, Time Span= 0.00-72.00 hrs, dt= 0.05 hrs
 Peak Elev= 9.43' @ 12.69 hrs Surf.Area= 688 sf Storage= 369 cf

Plug-Flow detention time= 65.3 min calculated for 1,052 cf (100% of inflow)
 Center-of-Mass det. time= 65.2 min (850.0 - 784.8)

Volume	Invert	Avail.Storage	Storage Description
#1	8.80'	645 cf	Custom Stage Data (Prismatic) Listed below (Recalc)
			960 cf Overall x 30.0% Voids
Elevation (feet)	Surf.Area (sq-ft)	Inc.Store (cubic-feet)	Cum.Store (cubic-feet)
8.80	480	0	0
9.80	810	645	645

Device	Routing	Invert	Outlet Devices
#1	Primary	7.60'	12.0" Round Culvert L= 10.0' CPP, square edge headwall, Ke= 0.500 Inlet / Outlet Invert= 7.60' / 7.50' S= 0.0100 '/ Cc= 0.900 n= 0.013, Flow Area= 0.79 sf
#2	Secondary	8.80'	2.410 in/hr Exfiltration over Surface area Conductivity to Groundwater Elevation = 5.60'
#3	Device 1	9.50'	24inch-Dome Grate Capacity

Primary OutFlow Max=0.00 cfs @ 0.00 hrs HW=8.80' (Free Discharge)

↑1=Culvert (Passes 0.00 cfs of 2.86 cfs potential flow)

↑3=24inch-Dome Grate Capacity (Controls 0.00 cfs)

Secondary OutFlow Max=0.04 cfs @ 12.69 hrs HW=9.43' (Free Discharge)

↑2=Exfiltration (Controls 0.04 cfs)

14850_Proposed-Drainage-Areas_220609

NOAA 24-hr C NOAA 10-yr Rainfall=5.02"

Prepared by {enter your company name here}

Printed 6/16/2022

HydroCAD® 10.10-7a s/n 00546 © 2021 HydroCAD Software Solutions LLC

Page 16

Summary for Pond 5A-PS: BB 5A-Stone

Inflow = 0.04 cfs @ 12.69 hrs, Volume= 1,052 cf
 Outflow = 0.04 cfs @ 12.78 hrs, Volume= 1,016 cf, Atten= 0%, Lag= 5.9 min
 Primary = 0.04 cfs @ 12.78 hrs, Volume= 1,016 cf
 Routed to Reach B : PARKING LOT B OVERFLOW

Routing by Stor-Ind method, Time Span= 0.00-72.00 hrs, dt= 0.05 hrs
 Peak Elev= 5.94' @ 12.78 hrs Surf.Area= 480 sf Storage= 56 cf

Plug-Flow detention time= 46.0 min calculated for 1,016 cf (97% of inflow)
 Center-of-Mass det. time= 26.8 min (876.8 - 850.0)

Volume	Invert	Avail.Storage	Storage Description
#1	5.55'	288 cf	Custom Stage Data (Prismatic) Listed below (Recalc)
			960 cf Overall x 30.0% Voids
Elevation (feet)	Surf.Area (sq-ft)	Inc.Store (cubic-feet)	Cum.Store (cubic-feet)
5.55	480	0	0
7.55	480	960	960

Device	Routing	Invert	Outlet Devices
#1	Primary	5.80'	4.0" Vert. Orifice/Grate C= 0.600 Limited to weir flow at low heads

Primary OutFlow Max=0.04 cfs @ 12.78 hrs HW=5.94' (Free Discharge)

↑1=Orifice/Grate (Orifice Controls 0.04 cfs @ 1.28 fps)

14850_Proposed-Drainage-Areas_220609

NOAA 24-hr C NOAA 10-yr Rainfall=5.02"

Prepared by {enter your company name here}

Printed 6/16/2022

HydroCAD® 10.10-7a s/n 00546 © 2021 HydroCAD Software Solutions LLC

Page 17

Summary for Pond 5B-P: BB 5B - POND

[93] Warning: Storage range exceeded by 0.04'

[88] Warning: Qout>Qin may require smaller dt or Finer Routing

Inflow Area = 34,755 sf, 71.39% Impervious, Inflow Depth = 4.00" for NOAA 10-yr event
 Inflow = 3.81 cfs @ 12.13 hrs, Volume= 11,589 cf
 Outflow = 3.92 cfs @ 12.14 hrs, Volume= 11,589 cf, Atten= 0%, Lag= 0.6 min
 Primary = 1.59 cfs @ 12.14 hrs, Volume= 931 cf
 Routed to Reach B : PARKING LOT B OVERFLOW
 Secondary = 0.09 cfs @ 12.13 hrs, Volume= 4,004 cf
 Routed to Pond 5B-PS : BB 5B-Stone
 Tertiary = 2.23 cfs @ 12.14 hrs, Volume= 6,654 cf
 Routed to Reach 6R : ISOLATOR ROW 2

Routing by Stor-Ind method, Time Span= 0.00-72.00 hrs, dt= 0.05 hrs
 Peak Elev= 9.04' @ 12.14 hrs Surf.Area= 1,450 sf Storage= 711 cf

Plug-Flow detention time= 28.2 min calculated for 11,589 cf (100% of inflow)
 Center-of-Mass det. time= 28.2 min (817.2 - 789.0)

Volume	Invert	Avail.Storage	Storage Description
#1	8.20'	711 cf	Custom Stage Data (Prismatic) Listed below (Recalc)

Elevation (feet)	Surf.Area (sq-ft)	Inc.Store (cubic-feet)	Cum.Store (cubic-feet)
8.20	327	0	0
9.00	1,450	711	711

Device	Routing	Invert	Outlet Devices
#1	Primary	7.00'	12.0" Round Culvert L= 10.0' CPP, square edge headwall, Ke= 0.500 Inlet / Outlet Invert= 7.00' / 6.90' S= 0.0100 '/ Cc= 0.900 n= 0.013, Flow Area= 0.79 sf
#2	Secondary	8.20'	2.410 in/hr Exfiltration over Surface area Conductivity to Groundwater Elevation = 5.00'
#3	Device 1	8.90'	24inchDome Grate Capacity X 2.00 Head (feet) 0.00 0.05 0.10 0.15 0.20 0.25 0.30 0.35 0.40 0.45 0.50 0.55 0.60 0.65 0.70 0.75 0.80 0.85 0.90 0.95 1.00 1.05 1.10 Disch. (cfs) 0.000 0.180 0.460 0.850 1.360 1.830 2.420 3.100 3.600 3.800 4.000 4.200 4.380 4.600 4.750 4.900 5.100 5.200 5.350 5.450 5.650 5.800 5.950
#4	Tertiary	8.70'	15inch-Dome Grate Capacity

14850_Proposed-Drainage-Areas_220609

NOAA 24-hr C NOAA 10-yr Rainfall=5.02"

Prepared by {enter your company name here}

Printed 6/16/2022

HydroCAD® 10.10-7a s/n 00546 © 2021 HydroCAD Software Solutions LLC

Page 18

Primary OutFlow Max=1.49 cfs @ 12.14 hrs HW=9.04' (Free Discharge)
 ↳1=Culvert (Passes 1.49 cfs of 4.69 cfs potential flow)
 ↳3=24inchDome Grate Capacity (Custom Controls 1.49 cfs)

Secondary OutFlow Max=0.09 cfs @ 12.13 hrs HW=9.03' (Free Discharge)
 ↳2=Exfiltration (Controls 0.09 cfs)

Tertiary OutFlow Max=2.18 cfs @ 12.14 hrs HW=9.04' (Free Discharge)
 ↳4=15inch-Dome Grate Capacity (Custom Controls 2.18 cfs)

14850_Proposed-Drainage-Areas_220609

NOAA 24-hr C NOAA 10-yr Rainfall=5.02"

Prepared by {enter your company name here}

Printed 6/16/2022

HydroCAD® 10.10-7a s/n 00546 © 2021 HydroCAD Software Solutions LLC

Page 19

Summary for Pond 5B-PS: BB 5B-Stone

Inflow = 0.09 cfs @ 12.13 hrs, Volume= 4,004 cf
 Outflow = 0.09 cfs @ 12.20 hrs, Volume= 3,953 cf, Atten= 3%, Lag= 3.9 min
 Primary = 0.09 cfs @ 12.20 hrs, Volume= 3,953 cf
 Routed to Reach B : PARKING LOT B OVERFLOW

Routing by Stor-Ind method, Time Span= 0.00-72.00 hrs, dt= 0.05 hrs
 Peak Elev= 5.46' @ 12.20 hrs Surf.Area= 690 sf Storage= 96 cf

Plug-Flow detention time= 27.1 min calculated for 3,953 cf (99% of inflow)
 Center-of-Mass det. time= 18.7 min (969.5 - 950.9)

Volume	Invert	Avail.Storage	Storage Description
#1	5.00'	414 cf	Custom Stage Data (Prismatic) Listed below (Recalc) 1,380 cf Overall x 30.0% Voids

Elevation (feet)	Surf.Area (sq-ft)	Inc.Store (cubic-feet)	Cum.Store (cubic-feet)
5.00	690	0	0
7.00	690	1,380	1,380

Device	Routing	Invert	Outlet Devices
#1	Primary	5.25'	4.0" Vert. Orifice/Grate C= 0.600 Limited to weir flow at low heads

Primary OutFlow Max=0.09 cfs @ 12.20 hrs HW=5.46' (Free Discharge)
 ↳ **1=Orifice/Grate** (Orifice Controls 0.09 cfs @ 1.57 fps)

14850_Proposed-Drainage-Areas_220609

NOAA 24-hr C NOAA 10-yr Rainfall=5.02"

Prepared by {enter your company name here}

Printed 6/16/2022

HydroCAD® 10.10-7a s/n 00546 © 2021 HydroCAD Software Solutions LLC

Page 20

Summary for Pond 6A-P: BB 6A - POND

Inflow Area = 15,148 sf, 46.97% Impervious, Inflow Depth = 3.39" for NOAA 10-yr event
 Inflow = 1.47 cfs @ 12.13 hrs, Volume= 4,275 cf
 Outflow = 1.43 cfs @ 12.15 hrs, Volume= 4,275 cf, Atten= 3%, Lag= 1.0 min
 Primary = 1.38 cfs @ 12.15 hrs, Volume= 2,347 cf
 Routed to Reach BMP6_O : BMP-6 OVERFLOW
 Secondary = 0.05 cfs @ 12.15 hrs, Volume= 1,928 cf
 Routed to Pond 6A-PS : BB 6A - STONE

Routing by Stor-Ind method, Time Span= 0.00-72.00 hrs, dt= 0.05 hrs
 Peak Elev= 11.00' @ 12.15 hrs Surf.Area= 698 sf Storage= 420 cf

Plug-Flow detention time= 41.9 min calculated for 4,272 cf (100% of inflow)
 Center-of-Mass det. time= 41.9 min (852.2 - 810.3)

Volume	Invert	Avail.Storage	Storage Description
#1	10.20'	491 cf	Custom Stage Data (Prismatic) Listed below (Recalc)

Elevation (feet)	Surf.Area (sq-ft)	Inc.Store (cubic-feet)	Cum.Store (cubic-feet)
10.20	350	0	0
11.10	740	491	491

Device	Routing	Invert	Outlet Devices
#1	Primary	9.00'	12.0" Round Culvert L= 10.0' CPP, square edge headwall, Ke= 0.500 Inlet / Outlet Invert= 9.00' / 8.90' S= 0.0100 '/ S= 0.0100 '/ Cc= 0.900 n= 0.013, Flow Area= 0.79 sf
#2	Secondary	10.20'	2.410 in/hr Exfiltration over Surface area Conductivity to Groundwater Elevation = 7.00'
#3	Device 1	10.80'	24inch-Dome Grate Capacity
#4	Primary	11.00'	5.0' long Sharp-Crested Rectangular Weir 2 End Contraction(s)

Primary OutFlow Max=1.36 cfs @ 12.15 hrs HW=11.00' (Free Discharge)
 ↳ **1=Culvert** (Passes 1.36 cfs of 4.63 cfs potential flow)
 ↳ **3=24inch-Dome Grate Capacity** (Custom Controls 1.36 cfs)
 ↳ **4=Sharp-Crested Rectangular Weir** (Weir Controls 0.00 cfs @ 0.07 fps)

Secondary OutFlow Max=0.05 cfs @ 12.15 hrs HW=11.00' (Free Discharge)
 ↳ **2=Exfiltration** (Controls 0.05 cfs)

14850_Proposed-Drainage-Areas_220609

NOAA 24-hr C NOAA 10-yr Rainfall=5.02"

Prepared by {enter your company name here}

Printed 6/16/2022

HydroCAD® 10.10-7a s/n 00546 © 2021 HydroCAD Software Solutions LLC

Page 21

Summary for Pond 6A-PS: BB 6A - STONE

Inflow = 0.05 cfs @ 12.15 hrs, Volume= 1,928 cf
 Outflow = 0.05 cfs @ 12.18 hrs, Volume= 1,906 cf, Atten= 1%, Lag= 2.2 min
 Primary = 0.05 cfs @ 12.18 hrs, Volume= 1,906 cf
 Routed to Reach BMP6_O : BMP-6 OVERFLOW

Routing by Stor-Ind method, Time Span= 0.00-72.00 hrs, dt= 0.05 hrs
 Peak Elev= 7.39' @ 12.18 hrs Surf.Area= 290 sf Storage= 34 cf

Plug-Flow detention time= 17.9 min calculated for 1,906 cf (99% of inflow)
 Center-of-Mass det. time= 11.8 min (994.3 - 982.4)

Volume	Invert	Avail.Storage	Storage Description
#1	7.00'	174 cf	Custom Stage Data (Prismatic) Listed below (Recalc) 580 cf Overall x 30.0% Voids

Elevation (feet)	Surf.Area (sq-ft)	Inc.Store (cubic-feet)	Cum.Store (cubic-feet)
7.00	290	0	0
9.00	290	580	580

Device	Routing	Invert	Outlet Devices
#1	Primary	7.25'	4.0" Vert. Orifice/Grate C= 0.600 Limited to weir flow at low heads

Primary OutFlow Max=0.05 cfs @ 12.18 hrs HW=7.39' (Free Discharge)
 ↳1=Orifice/Grate (Orifice Controls 0.05 cfs @ 1.28 fps)

14850_Proposed-Drainage-Areas_220609

NOAA 24-hr C NOAA 10-yr Rainfall=5.02"

Prepared by {enter your company name here}

Printed 6/16/2022

HydroCAD® 10.10-7a s/n 00546 © 2021 HydroCAD Software Solutions LLC

Page 22

Summary for Pond 6B-P: BB 6B

Inflow Area = 6,495 sf, 77.45% Impervious, Inflow Depth = 4.22" for NOAA 10-yr event
 Inflow = 0.73 cfs @ 12.13 hrs, Volume= 2,283 cf
 Outflow = 0.71 cfs @ 12.15 hrs, Volume= 2,283 cf, Atten= 4%, Lag= 1.3 min
 Discarded = 0.02 cfs @ 12.15 hrs, Volume= 1,071 cf
 Primary = 0.69 cfs @ 12.15 hrs, Volume= 1,212 cf
 Routed to Reach BMP6_O : BMP-6 OVERFLOW

Routing by Stor-Ind method, Time Span= 0.00-72.00 hrs, dt= 0.05 hrs
 Peak Elev= 12.08' @ 12.15 hrs Surf.Area= 678 sf Storage= 380 cf

Plug-Flow detention time= 110.1 min calculated for 2,281 cf (100% of inflow)
 Center-of-Mass det. time= 110.3 min (890.5 - 780.2)

Volume	Invert	Avail.Storage	Storage Description
#1	11.20'	394 cf	Custom Stage Data (Prismatic) Listed below (Recalc)

Elevation (feet)	Surf.Area (sq-ft)	Inc.Store (cubic-feet)	Cum.Store (cubic-feet)
11.20	185	0	0
12.10	690	394	394

Device	Routing	Invert	Outlet Devices
#1	Primary	10.10'	12.0" Round Culvert L= 10.0' CPP, square edge headwall, Ke= 0.500 Inlet / Outlet Invert= 10.10' / 10.00' S= 0.0100 ' / Cc= 0.900 n= 0.013, Flow Area= 0.79 sf
#2	Discarded	11.20'	1.020 in/hr Exfiltration over Surface area Conductivity to Groundwater Elevation = 8.10'
#3	Device 1	11.95'	24inch-Dome Grate Capacity

Discarded OutFlow Max=0.02 cfs @ 12.15 hrs HW=12.08' (Free Discharge)
 ↳2=Exfiltration (Controls 0.02 cfs)

Primary OutFlow Max=0.68 cfs @ 12.15 hrs HW=12.08' (Free Discharge)
 ↳1=Culvert (Passes 0.68 cfs of 4.60 cfs potential flow)
 ↳3=24inch-Dome Grate Capacity (Custom Controls 0.68 cfs)

14850_Proposed-Drainage-Areas_220609

NOAA 24-hr C NOAA 10-yr Rainfall=5.02"

Prepared by {enter your company name here}

Printed 6/16/2022

HydroCAD® 10.10-7a s/n 00546 © 2021 HydroCAD Software Solutions LLC

Page 23

Summary for Pond 7A-P: BB 7A PONDING

Inflow Area = 3,165 sf, 87.74% Impervious, Inflow Depth = 4.44" for NOAA 10-yr event
 Inflow = 0.37 cfs @ 12.13 hrs, Volume= 1,171 cf
 Outflow = 0.36 cfs @ 12.14 hrs, Volume= 1,171 cf, Atten= 2%, Lag= 0.9 min
 Primary = 0.34 cfs @ 12.14 hrs, Volume= 465 cf
 Routed to Reach 7R : PARKING LOT C to HUDSON
 Secondary = 0.02 cfs @ 12.14 hrs, Volume= 706 cf
 Routed to Pond 7A-S : BB 7A - STONE

Routing by Stor-Ind method, Time Span= 0.00-72.00 hrs, dt= 0.05 hrs
 Peak Elev= 9.98' @ 12.14 hrs Surf.Area= 322 sf Storage= 148 cf

Plug-Flow detention time= 39.4 min calculated for 1,171 cf (100% of inflow)
 Center-of-Mass det. time= 39.4 min (809.1 - 769.8)

Volume	Invert	Avail.Storage	Storage Description
#1	9.30'	227 cf	Custom Stage Data (Prismatic) Listed below (Recalc)
Elevation (feet)	Surf.Area (sq-ft)	Inc.Store (cubic-feet)	Cum.Store (cubic-feet)
9.30	115	0	0
10.20	390	227	227

Device	Routing	Invert	Outlet Devices
#1	Primary	8.10'	12.0" Round Culvert L= 10.0' CPP, square edge headwall, Ke= 0.500 Inlet / Outlet Invert= 8.10' / 8.00' S= 0.0100 '/ Cc= 0.900 n= 0.013, Flow Area= 0.79 sf
#2	Secondary	9.30'	2.410 in/hr Exfiltration over Surface area Conductivity to Groundwater Elevation = 6.10'
#3	Device 1	9.90'	24inch-Dome Grate Capacity
#4	Primary	10.10'	5.0' long Sharp-Crested Rectangular Weir 2 End Contraction(s)

Primary OutFlow Max=0.33 cfs @ 12.14 hrs HW=9.98' (Free Discharge)

↑1=Culvert (Passes 0.33 cfs of 4.44 cfs potential flow)

↑3=24inch-Dome Grate Capacity (Custom Controls 0.33 cfs)

↑4=Sharp-Crested Rectangular Weir (Controls 0.00 cfs)

Secondary OutFlow Max=0.02 cfs @ 12.14 hrs HW=9.98' (Free Discharge)

↑2=Exfiltration (Controls 0.02 cfs)

14850_Proposed-Drainage-Areas_220609

NOAA 24-hr C NOAA 10-yr Rainfall=5.02"

Prepared by {enter your company name here}

Printed 6/16/2022

HydroCAD® 10.10-7a s/n 00546 © 2021 HydroCAD Software Solutions LLC

Page 24

Summary for Pond 7A-S: BB 7A - STONE

Inflow = 0.02 cfs @ 12.14 hrs, Volume= 706 cf
 Outflow = 0.02 cfs @ 12.17 hrs, Volume= 706 cf, Atten= 0%, Lag= 1.5 min
 Primary = 0.02 cfs @ 12.17 hrs, Volume= 706 cf
 Routed to Reach 7R : PARKING LOT C to HUDSON

Routing by Stor-Ind method, Time Span= 0.00-72.00 hrs, dt= 0.05 hrs
 Peak Elev= 5.19' @ 12.17 hrs Surf.Area= 150 sf Storage= 4 cf

Plug-Flow detention time= 4.8 min calculated for 706 cf (100% of inflow)
 Center-of-Mass det. time= 4.7 min (863.0 - 858.3)

Volume	Invert	Avail.Storage	Storage Description
#1	5.10'	90 cf	Custom Stage Data (Prismatic) Listed below (Recalc) 300 cf Overall x 30.0% Voids

Elevation (feet)	Surf.Area (sq-ft)	Inc.Store (cubic-feet)	Cum.Store (cubic-feet)
5.10	150	0	0
7.10	150	300	300

Device	Routing	Invert	Outlet Devices
#1	Primary	5.10'	4.0" Vert. Orifice/Grate C= 0.600 Limited to weir flow at low heads

Primary OutFlow Max=0.02 cfs @ 12.17 hrs HW=5.19' (Free Discharge)

↑1=Orifice/Grate (Orifice Controls 0.02 cfs @ 1.03 fps)

14850_Proposed-Drainage-Areas_220609

NOAA 24-hr C NOAA 10-yr Rainfall=5.02"

Prepared by {enter your company name here}

Printed 6/16/2022

HydroCAD® 10.10-7a s/n 00546 © 2021 HydroCAD Software Solutions LLC

Page 25

Summary for Pond 7B-P: BB 7B PONDING

Inflow Area = 4,942 sf, 88.73% Impervious, Inflow Depth = 4.44" for NOAA 10-yr event
 Inflow = 0.57 cfs @ 12.13 hrs, Volume= 1,828 cf
 Outflow = 0.56 cfs @ 12.15 hrs, Volume= 1,828 cf, Atten= 3%, Lag= 1.2 min
 Primary = 0.52 cfs @ 12.15 hrs, Volume= 676 cf
 Routed to Reach BMP7_O : BMP-7 OVERFLOW
 Secondary = 0.03 cfs @ 12.15 hrs, Volume= 1,153 cf
 Routed to Pond 7B-S : BB 7B - STONE

Routing by Stor-Ind method, Time Span= 0.00-72.00 hrs, dt= 0.05 hrs
 Peak Elev= 10.71' @ 12.15 hrs Surf.Area= 524 sf Storage= 274 cf

Plug-Flow detention time= 41.6 min calculated for 1,828 cf (100% of inflow)
 Center-of-Mass det. time= 41.6 min (811.3 - 769.8)

Volume	Invert	Avail.Storage	Storage Description
#1	10.00'	324 cf	Custom Stage Data (Prismatic) Listed below (Recalc)
Elevation (feet)	Surf.Area (sq-ft)	Inc.Store (cubic-feet)	Cum.Store (cubic-feet)
10.00	250	0	0
10.80	560	324	324

Device	Routing	Invert	Outlet Devices
#1	Primary	8.90'	12.0" Round Culvert L= 10.0' CPP, square edge headwall, Ke= 0.500 Inlet / Outlet Invert= 8.90' / 8.80' S= 0.0100 '/ Cc= 0.900 n= 0.013, Flow Area= 0.79 sf
#2	Secondary	10.00'	2.410 in/hr Exfiltration over Surface area Conductivity to Groundwater Elevation = 6.90'
#3	Device 1	10.60'	24inch-Dome Grate Capacity

Primary OutFlow Max=0.52 cfs @ 12.15 hrs HW=10.71' (Free Discharge)

↳ **1=Culvert** (Passes 0.52 cfs of 4.32 cfs potential flow)

↳ **3=24inch-Dome Grate Capacity** (Custom Controls 0.52 cfs)

Secondary OutFlow Max=0.03 cfs @ 12.15 hrs HW=10.71' (Free Discharge)

↳ **2=Exfiltration** (Controls 0.03 cfs)

14850_Proposed-Drainage-Areas_220609

NOAA 24-hr C NOAA 10-yr Rainfall=5.02"

Prepared by {enter your company name here}

Printed 6/16/2022

HydroCAD® 10.10-7a s/n 00546 © 2021 HydroCAD Software Solutions LLC

Page 26

Summary for Pond 7B-S: BB 7B - STONE

Inflow = 0.03 cfs @ 12.15 hrs, Volume= 1,153 cf
 Outflow = 0.03 cfs @ 12.17 hrs, Volume= 1,141 cf, Atten= 0%, Lag= 1.4 min
 Primary = 0.03 cfs @ 12.17 hrs, Volume= 1,141 cf
 Routed to Reach BMP7_O : BMP-7 OVERFLOW

Routing by Stor-Ind method, Time Span= 0.00-72.00 hrs, dt= 0.05 hrs
 Peak Elev= 7.62' @ 12.17 hrs Surf.Area= 150 sf Storage= 17 cf

Plug-Flow detention time= 16.0 min calculated for 1,141 cf (99% of inflow)
 Center-of-Mass det. time= 10.1 min (865.5 - 855.4)

Volume	Invert	Avail.Storage	Storage Description
#1	7.25'	90 cf	Custom Stage Data (Prismatic) Listed below (Recalc) 300 cf Overall x 30.0% Voids

Elevation (feet)	Surf.Area (sq-ft)	Inc.Store (cubic-feet)	Cum.Store (cubic-feet)
7.25	150	0	0
9.25	150	300	300

Device	Routing	Invert	Outlet Devices
#1	Primary	7.50'	4.0" Vert. Orifice/Grate C= 0.600 Limited to weir flow at low heads

Primary OutFlow Max=0.03 cfs @ 12.17 hrs HW=7.62' (Free Discharge)

↳ **1=Orifice/Grate** (Orifice Controls 0.03 cfs @ 1.18 fps)

14850_Proposed-Drainage-Areas_220609

NOAA 24-hr C NOAA 10-yr Rainfall=5.02"

Prepared by {enter your company name here}

Printed 6/16/2022

HydroCAD® 10.10-7a s/n 00546 © 2021 HydroCAD Software Solutions LLC

Page 27

Summary for Pond 8a-P: BB 8A PONDING

Inflow Area = 3,978 sf, 79.99% Impervious, Inflow Depth = 4.22" for NOAA 10-yr event

Inflow = 0.45 cfs @ 12.13 hrs, Volume= 1,398 cf

Outflow = 0.42 cfs @ 12.16 hrs, Volume= 1,398 cf, Atten= 6%, Lag= 2.0 min

Primary = 0.38 cfs @ 12.16 hrs, Volume= 357 cf

Routed to Reach P ST : PORTLAND STREET DRAINAGE

Secondary = 0.04 cfs @ 12.16 hrs, Volume= 1,041 cf

Routed to Pond 8a-s : BB 8A - STONE

Routing by Stor-Ind method, Time Span= 0.00-72.00 hrs, dt= 0.05 hrs

Peak Elev= 9.09' @ 12.16 hrs Surf.Area= 612 sf Storage= 285 cf

Plug-Flow detention time= 39.7 min calculated for 1,398 cf (100% of inflow)

Center-of-Mass det. time= 39.7 min (819.9 - 780.2)

Volume	Invert	Avail.Storage	Storage Description
#1	8.50'	575 cf	Custom Stage Data (Prismatic) Listed below (Recalc)
Elevation (feet)	Surf.Area (sq-ft)	Inc.Store (cubic-feet)	Cum.Store (cubic-feet)
8.50	360	0	0
9.50	790	575	575

Device	Routing	Invert	Outlet Devices
#1	Primary	7.40'	12.0" Round Culvert L= 10.0' CPP, square edge headwall, Ke= 0.500 Inlet / Outlet Invert= 7.40' / 7.30' S= 0.0100 1' Cc= 0.900 n= 0.013, Flow Area= 0.79 sf
#2	Secondary	8.50'	2.410 in/hr Exfiltration over Surface area Conductivity to Groundwater Elevation = 5.40'
#3	Device 1	9.00'	24inch-Dome Grate Capacity
#4	Primary	9.40'	5.0' long Sharp-Crested Rectangular Weir 2 End Contraction(s)

Primary OutFlow Max=0.37 cfs @ 12.16 hrs HW=9.08' (Free Discharge)

1=Culvert (Passes 0.37 cfs of 4.11 cfs potential flow)

3=24inch-Dome Grate Capacity (Custom Controls 0.37 cfs)

4=Sharp-Crested Rectangular Weir (Controls 0.00 cfs)

Secondary OutFlow Max=0.04 cfs @ 12.16 hrs HW=9.08' (Free Discharge)

2=Exfiltration (Controls 0.04 cfs)

14850_Proposed-Drainage-Areas_220609

NOAA 24-hr C NOAA 10-yr Rainfall=5.02"

Prepared by {enter your company name here}

Printed 6/16/2022

HydroCAD® 10.10-7a s/n 00546 © 2021 HydroCAD Software Solutions LLC

Page 28

Summary for Pond 8a-s: BB 8A - STONE

Inflow = 0.04 cfs @ 12.16 hrs, Volume= 1,041 cf

Outflow = 0.04 cfs @ 12.22 hrs, Volume= 1,023 cf, Atten= 1%, Lag= 3.3 min

Primary = 0.04 cfs @ 12.22 hrs, Volume= 1,023 cf

Routed to Reach P ST : PORTLAND STREET DRAINAGE

Routing by Stor-Ind method, Time Span= 0.00-72.00 hrs, dt= 0.05 hrs

Peak Elev= 5.63' @ 12.22 hrs Surf.Area= 300 sf Storage= 30 cf

Plug-Flow detention time= 27.7 min calculated for 1,023 cf (98% of inflow)

Center-of-Mass det. time= 17.0 min (865.0 - 848.0)

Volume	Invert	Avail.Storage	Storage Description
#1	5.30'	180 cf	Custom Stage Data (Prismatic) Listed below (Recalc) 600 cf Overall x 30.0% Voids

Elevation (feet)	Surf.Area (sq-ft)	Inc.Store (cubic-feet)	Cum.Store (cubic-feet)
5.30	300	0	0
7.30	300	600	600

Device	Routing	Invert	Outlet Devices
#1	Primary	5.50'	4.0" Vert. Orifice/Grate C= 0.600 Limited to weir flow at low heads

Primary OutFlow Max=0.04 cfs @ 12.22 hrs HW=5.63' (Free Discharge)

1=Orifice/Grate (Orifice Controls 0.04 cfs @ 1.23 fps)

14850_Proposed-Drainage-Areas_220609

NOAA 24-hr C NOAA 10-yr Rainfall=5.02"

Prepared by {enter your company name here}

Printed 6/16/2022

HydroCAD® 10.10-7a s/n 00546 © 2021 HydroCAD Software Solutions LLC

Page 29

Summary for Pond 8B-P: BB 8B-PONDING

Inflow Area = 5,598 sf, 87.78% Impervious, Inflow Depth = 4.44" for NOAA 10-yr event
 Inflow = 0.65 cfs @ 12.13 hrs, Volume= 2,071 cf
 Outflow = 0.64 cfs @ 12.14 hrs, Volume= 2,071 cf, Atten= 2%, Lag= 0.9 min
 Primary = 0.60 cfs @ 12.14 hrs, Volume= 805 cf

Routed to Reach 7R : PARKING LOT C to HUDSON

Secondary = 0.04 cfs @ 12.14 hrs, Volume= 1,266 cf

Routed to Pond 8B-S : BB 8B-Stone

Routing by Stor-Ind method, Time Span= 0.00-72.00 hrs, dt= 0.05 hrs

Peak Elev= 9.72' @ 12.14 hrs Surf.Area= 629 sf Storage= 255 cf

Plug-Flow detention time= 35.5 min calculated for 2,071 cf (100% of inflow)

Center-of-Mass det. time= 35.5 min (805.2 - 769.8)

Volume	Invert	Avail.Storage	Storage Description
#1	9.10'	306 cf	Custom Stage Data (Prismatic) Listed below (Recalc)
Elevation (feet)	Surf.Area (sq-ft)	Inc.Store (cubic-feet)	Cum.Store (cubic-feet)
9.10	190	0	0
9.80	685	306	306

Device	Routing	Invert	Outlet Devices
#1	Primary	7.90'	12.0" Round Culvert L= 10.0' CPP, square edge headwall, Ke= 0.500 Inlet / Outlet Invert= 7.90' / 7.80' S= 0.0100 '/ Cc= 0.900 n= 0.013, Flow Area= 0.79 sf
#2	Secondary	9.10'	2.410 in/hr Exfiltration over Surface area Conductivity to Groundwater Elevation = 5.90'
#3	Device 1	9.65'	24inch-Dome Grate Capacity X 2.00

Primary OutFlow Max=0.59 cfs @ 12.14 hrs HW=9.72' (Free Discharge)

↑1=Culvert (Passes 0.59 cfs of 4.34 cfs potential flow)

↑3=24inch-Dome Grate Capacity (Custom Controls 0.59 cfs)

Secondary OutFlow Max=0.04 cfs @ 12.14 hrs HW=9.72' (Free Discharge)

↑2=Exfiltration (Controls 0.04 cfs)

14850_Proposed-Drainage-Areas_220609

NOAA 24-hr C NOAA 10-yr Rainfall=5.02"

Prepared by {enter your company name here}

Printed 6/16/2022

HydroCAD® 10.10-7a s/n 00546 © 2021 HydroCAD Software Solutions LLC

Page 30

Summary for Pond 8B-S: BB 8B-Stone

Inflow = 0.04 cfs @ 12.14 hrs, Volume= 1,266 cf
 Outflow = 0.04 cfs @ 12.18 hrs, Volume= 1,239 cf, Atten= 1%, Lag= 2.2 min
 Primary = 0.04 cfs @ 12.18 hrs, Volume= 1,239 cf
 Routed to Reach 7R : PARKING LOT C to HUDSON

Routing by Stor-Ind method, Time Span= 0.00-72.00 hrs, dt= 0.05 hrs

Peak Elev= 6.33' @ 12.18 hrs Surf.Area= 300 sf Storage= 39 cf

Plug-Flow detention time= 32.8 min calculated for 1,239 cf (98% of inflow)

Center-of-Mass det. time= 20.2 min (870.8 - 850.6)

Volume	Invert	Avail.Storage	Storage Description
#1	5.90'	180 cf	Custom Stage Data (Prismatic) Listed below (Recalc) 600 cf Overall x 30.0% Voids

Elevation (feet)	Surf.Area (sq-ft)	Inc.Store (cubic-feet)	Cum.Store (cubic-feet)
5.90	300	0	0
7.90	300	600	600

Device	Routing	Invert	Outlet Devices
#1	Primary	6.20'	4.0" Vert. Orifice/Grate C= 0.600 Limited to weir flow at low heads

Primary OutFlow Max=0.04 cfs @ 12.18 hrs HW=6.33' (Free Discharge)

↑1=Orifice/Grate (Orifice Controls 0.04 cfs @ 1.23 fps)

14850_Proposed-Drainage-Areas_220609

NOAA 24-hr C NOAA 10-yr Rainfall=5.02"

Prepared by {enter your company name here}

Printed 6/16/2022

HydroCAD® 10.10-7a s/n 00546 © 2021 HydroCAD Software Solutions LLC

Page 31

Summary for Pond 9-P: BB9 - POND

Inflow Area = 29,651 sf, 74.77% Impervious, Inflow Depth = 4.11" for NOAA 10-yr event
 Inflow = 3.30 cfs @ 12.13 hrs, Volume= 10,153 cf
 Outflow = 3.22 cfs @ 12.15 hrs, Volume= 10,153 cf, Atten= 2%, Lag= 1.1 min
 Primary = 0.67 cfs @ 12.15 hrs, Volume= 245 cf
 Routed to Reach BMP9_O : BMP-9 OVERFLOW
 Secondary = 0.05 cfs @ 12.15 hrs, Volume= 2,215 cf
 Routed to Pond 9-PS : BB9 - STONE
 Tertiary = 2.51 cfs @ 12.15 hrs, Volume= 7,693 cf
 Routed to Reach 1R : ISOLATOR ROW C

Routing by Stor-Ind method, Time Span= 0.00-72.00 hrs, dt= 0.05 hrs
 Peak Elev= 8.93' @ 12.15 hrs Surf.Area= 737 sf Storage= 430 cf

Plug-Flow detention time= 19.4 min calculated for 10,153 cf (100% of inflow)
 Center-of-Mass det. time= 19.4 min (804.2 - 784.8)

Volume	Invert	Avail.Storage	Storage Description
#1	8.00'	485 cf	Custom Stage Data (Prismatic) Listed below (Recalc)

Elevation (feet)	Surf.Area (sq-ft)	Inc.Store (cubic-feet)	Cum.Store (cubic-feet)
8.00	190	0	0
9.00	780	485	485

Device	Routing	Invert	Outlet Devices
#1	Primary	7.00'	12.0" Round Culvert L= 10.0' CPP, square edge headwall, Ke= 0.500 Inlet / Outlet Invert= 7.00' / 6.90' S= 0.0100 '/ Cc= 0.900 n= 0.013, Flow Area= 0.79 sf
#2	Secondary	8.00'	2.410 in/hr Exfiltration over Surface area Conductivity to Groundwater Elevation = 5.00'
#3	Device 1	8.80'	24inchDome Grate Capacity Head (feet) 0.00 0.05 0.10 0.15 0.20 0.25 0.30 0.35 0.40 0.45 0.50 0.55 0.60 0.65 0.70 0.75 0.80 0.85 0.90 0.95 1.00 1.05 1.10 Disch. (cfs) 0.000 0.180 0.460 0.850 1.360 1.830 2.420 3.100 3.600 3.800 4.000 4.200 4.380 4.600 4.750 4.900 5.100 5.200 5.350 5.450 5.650 5.800 5.950
#4	Tertiary	8.50'	15inch-Dome Grate Capacity

Primary OutFlow Max=0.64 cfs @ 12.15 hrs HW=8.92' (Free Discharge)

↳ **1=Culvert** (Passes 0.64 cfs of 4.51 cfs potential flow)

↳ **3=24inchDome Grate Capacity** (Custom Controls 0.64 cfs)

Secondary OutFlow Max=0.05 cfs @ 12.15 hrs HW=8.92' (Free Discharge)

↳ **2=Exfiltration** (Controls 0.05 cfs)

Tertiary OutFlow Max=2.49 cfs @ 12.15 hrs HW=8.92' (Free Discharge)

↳ **4=15inch-Dome Grate Capacity** (Custom Controls 2.49 cfs)

14850_Proposed-Drainage-Areas_220609

NOAA 24-hr C NOAA 10-yr Rainfall=5.02"

Prepared by {enter your company name here}

Printed 6/16/2022

HydroCAD® 10.10-7a s/n 00546 © 2021 HydroCAD Software Solutions LLC

Page 32

Summary for Pond 9-PS: BB9 - STONE

Inflow = 0.05 cfs @ 12.15 hrs, Volume= 2,215 cf
 Outflow = 0.05 cfs @ 12.17 hrs, Volume= 2,200 cf, Atten= 2%, Lag= 1.5 min
 Primary = 0.05 cfs @ 12.17 hrs, Volume= 2,200 cf
 Routed to Reach BMP9_O : BMP-9 OVERFLOW

Routing by Stor-Ind method, Time Span= 0.00-72.00 hrs, dt= 0.05 hrs
 Peak Elev= 5.40' @ 12.17 hrs Surf.Area= 190 sf Storage= 23 cf

Plug-Flow detention time= 12.7 min calculated for 2,200 cf (99% of inflow)
 Center-of-Mass det. time= 8.3 min (949.2 - 940.9)

Volume	Invert	Avail.Storage	Storage Description
#1	5.00'	114 cf	Custom Stage Data (Prismatic) Listed below (Recalc) 380 cf Overall x 30.0% Voids

Elevation (feet)	Surf.Area (sq-ft)	Inc.Store (cubic-feet)	Cum.Store (cubic-feet)
5.00	190	0	0
7.00	190	380	380

Device	Routing	Invert	Outlet Devices
#1	Primary	5.25'	4.0" Vert. Orifice/Grate C= 0.600 Limited to weir flow at low heads

Primary OutFlow Max=0.05 cfs @ 12.17 hrs HW=5.40' (Free Discharge)

↳ **1=Orifice/Grate** (Orifice Controls 0.05 cfs @ 1.30 fps)

14850_Proposed-Drainage-Areas_220609

NOAA 24-hr C NOAA 10-yr Rainfall=5.02"

Prepared by {enter your company name here}

Printed 6/16/2022

HydroCAD® 10.10-7a s/n 00546 © 2021 HydroCAD Software Solutions LLC

Page 33

Summary for Pond 14P: BB2A-Stone

Inflow = 0.03 cfs @ 12.15 hrs, Volume= 873 cf
 Outflow = 0.03 cfs @ 12.19 hrs, Volume= 873 cf, Atten= 0%, Lag= 2.2 min
 Primary = 0.03 cfs @ 12.19 hrs, Volume= 873 cf
 Routed to Reach DP-1 : French Rodney Blvd Outfall

Routing by Stor-Ind method, Time Span= 0.00-72.00 hrs, dt= 0.05 hrs
 Peak Elev= 5.61' @ 12.19 hrs Surf.Area= 180 sf Storage= 6 cf

Plug-Flow detention time= 5.1 min calculated for 872 cf (100% of inflow)
 Center-of-Mass det. time= 5.1 min (860.8 - 855.7)

Volume	Invert	Avail.Storage	Storage Description
#1	5.50'	108 cf	Custom Stage Data (Prismatic) Listed below (Recalc) 360 cf Overall x 30.0% Voids

Elevation (feet)	Surf.Area (sq-ft)	Inc.Store (cubic-feet)	Cum.Store (cubic-feet)
5.50	180	0	0
7.50	180	360	360

Device	Routing	Invert	Outlet Devices
#1	Primary	5.50'	4.0" Vert. Orifice/Grate C= 0.600 Limited to weir flow at low heads

Primary OutFlow Max=0.03 cfs @ 12.19 hrs HW=5.61' (Free Discharge)
 ↳1=Orifice/Grate (Orifice Controls 0.03 cfs @ 1.11 fps)

14850_Proposed-Drainage-Areas_220609

NOAA 24-hr C NOAA 10-yr Rainfall=5.02"

Prepared by {enter your company name here}

Printed 6/16/2022

HydroCAD® 10.10-7a s/n 00546 © 2021 HydroCAD Software Solutions LLC

Page 34

Summary for Pond DMH1: DIVERSION MANHOLE - SEYMOUR ST

[57] Hint: Peaked at 9.81' (Flood elevation advised)

Inflow Area = 19,582 sf, 58.17% Impervious, Inflow Depth = 3.69" for NOAA 10-yr event
 Inflow = 2.03 cfs @ 12.13 hrs, Volume= 6,018 cf
 Outflow = 2.03 cfs @ 12.13 hrs, Volume= 6,018 cf, Atten= 0%, Lag= 0.0 min
 Primary = 0.71 cfs @ 12.13 hrs, Volume= 4,632 cf
 Routed to Pond INF-1 : INFILTRATION SYSTEM #1
 Secondary = 1.32 cfs @ 12.13 hrs, Volume= 1,386 cf
 Routed to Reach DP-1 : French Rodney Blvd Outfall

Routing by Stor-Ind method, Time Span= 0.00-72.00 hrs, dt= 0.05 hrs
 Peak Elev= 9.81' @ 12.13 hrs

Device	Routing	Invert	Outlet Devices
#1	Primary	9.00'	6.0" Vert. WATER QUALITY STORM DIVERSION C= 0.600 Limited to weir flow at low heads
#2	Secondary	9.20'	12.0" Vert. LARGE STORM OVEFLOW C= 0.600 Limited to weir flow at low heads

Primary OutFlow Max=0.69 cfs @ 12.13 hrs HW=9.79' (Free Discharge)
 ↳1=WATER QUALITY STORM DIVERSION(Orifice Controls 0.69 cfs @ 3.53 fps)

Secondary OutFlow Max=1.25 cfs @ 12.13 hrs HW=9.79' (Free Discharge)
 ↳2=LARGE STORM OVEFLOW (Orifice Controls 1.25 cfs @ 2.61 fps)

14850_Proposed-Drainage-Areas_220609

NOAA 24-hr C NOAA 10-yr Rainfall=5.02"

Prepared by {enter your company name here}

Printed 6/16/2022

HydroCAD® 10.10-7a s/n 00546 © 2021 HydroCAD Software Solutions LLC

Page 35

Summary for Pond DMH2: DIVERSION MANHOLE - HUDSON STREET

[57] Hint: Peaked at 20.37' (Flood elevation advised)

Inflow Area = 143,309 sf, 49.69% Impervious, Inflow Depth = 3.49' for NOAA 10-yr event
 Inflow = 14.20 cfs @ 12.13 hrs, Volume= 41,627 cf
 Outflow = 14.20 cfs @ 12.13 hrs, Volume= 41,627 cf, Atten= 0%, Lag= 0.0 min
 Primary = 2.93 cfs @ 12.13 hrs, Volume= 23,559 cf
 Routed to Pond INF-2 : INFILTRATION SYSTEM #2
 Secondary = 11.27 cfs @ 12.13 hrs, Volume= 18,068 cf
 Routed to Reach B : PARKING LOT B OVERFLOW

Routing by Stor-Ind method, Time Span= 0.00-72.00 hrs, dt= 0.05 hrs
 Peak Elev= 20.37' @ 12.13 hrs

Device	Routing	Invert	Outlet Devices
#1	Primary	10.60'	6.0" Vert. WATER QUALITY STORM DIVERSION C= 0.600 Limited to weir flow at low heads
#2	Secondary	11.10'	12.0" Vert. LARGE STORM OVERFLOW C= 0.600 Limited to weir flow at low heads

Primary OutFlow Max=2.82 cfs @ 12.13 hrs HW=19.76' (Free Discharge)
 ↳1=WATER QUALITY STORM DIVERSION(Orifice Controls 2.82 cfs @ 14.37 fps)

Secondary OutFlow Max=10.80 cfs @ 12.13 hrs HW=19.76' (Free Discharge)
 ↳2=LARGE STORM OVERFLOW(Orifice Controls 10.80 cfs @ 13.76 fps)

14850_Proposed-Drainage-Areas_220609

NOAA 24-hr C NOAA 10-yr Rainfall=5.02"

Prepared by {enter your company name here}

Printed 6/16/2022

HydroCAD® 10.10-7a s/n 00546 © 2021 HydroCAD Software Solutions LLC

Page 36

Summary for Pond DMH3: DIVERSION MANHOLE - PORTLAND ST

[57] Hint: Peaked at 11.73' (Flood elevation advised)

Inflow Area = 19,743 sf, 50.83% Impervious, Inflow Depth = 3.49' for NOAA 10-yr event
 Inflow = 1.96 cfs @ 12.13 hrs, Volume= 5,735 cf
 Outflow = 1.96 cfs @ 12.13 hrs, Volume= 5,735 cf, Atten= 0%, Lag= 0.0 min
 Primary = 1.06 cfs @ 12.13 hrs, Volume= 4,862 cf
 Routed to Pond INF3 : INFILTRATION SYSTEM #1
 Secondary = 0.90 cfs @ 12.13 hrs, Volume= 872 cf
 Routed to Reach P ST : PORTLAND STREET DRAINAGE

Routing by Stor-Ind method, Time Span= 0.00-72.00 hrs, dt= 0.05 hrs
 Peak Elev= 11.73' @ 12.13 hrs

Device	Routing	Invert	Outlet Devices
#1	Primary	11.00'	8.0" Vert. WATER QUALITY DIVERSION C= 0.600 Limited to weir flow at low heads
#2	Secondary	11.20'	10.0" Vert. LARGE STORM OVERFLOW C= 0.600 Limited to weir flow at low heads

Primary OutFlow Max=1.03 cfs @ 12.13 hrs HW=11.71' (Free Discharge)
 ↳1=WATER QUALITY DIVERSION(Orifice Controls 1.03 cfs @ 2.95 fps)

Secondary OutFlow Max=0.85 cfs @ 12.13 hrs HW=11.71' (Free Discharge)
 ↳2=LARGE STORM OVERFLOW(Orifice Controls 0.85 cfs @ 2.43 fps)

14850_Proposed-Drainage-Areas_220609

NOAA 24-hr C NOAA 10-yr Rainfall=5.02"

Prepared by {enter your company name here}

Printed 6/16/2022

HydroCAD® 10.10-7a s/n 00546 © 2021 HydroCAD Software Solutions LLC

Page 37

Summary for Pond INF-1: INFILTRATION SYSTEM #1

[81] Warning: Exceeded Pond DMH1 by 0.24' @ 14.90 hrs

Inflow Area = 19,582 sf, 58.17% Impervious, Inflow Depth = 2.84" for NOAA 10-yr event
 Inflow = 0.71 cfs @ 12.13 hrs, Volume= 4,632 cf
 Outflow = 0.23 cfs @ 12.69 hrs, Volume= 4,632 cf, Atten= 67%, Lag= 33.4 min
 Discarded = 0.08 cfs @ 12.69 hrs, Volume= 4,195 cf
 Primary = 0.15 cfs @ 12.69 hrs, Volume= 437 cf
 Routed to Reach DP-1 : French Rodney Blvd Outfall

Routing by Stor-Ind method, Time Span= 0.00-72.00 hrs, dt= 0.05 hrs
 Peak Elev= 9.44' @ 12.69 hrs Surf.Area= 1,772 sf Storage= 1,658 cf

Plug-Flow detention time= 216.5 min calculated for 4,629 cf (100% of inflow)
 Center-of-Mass det. time= 216.5 min (1,038.5 - 822.0)

Volume	Invert	Avail.Storage	Storage Description
#1A	7.80'	1,091 cf	21.50'W x 81.52'L x 2.33'H Field A 4,090 cf Overall - 973 cf Embedded = 3,117 cf x 35.0% Voids
#2A	8.30'	973 cf	ADS_StormTech SC-310 +Cap x 66 Inside #1 Effective Size= 28.9"W x 16.0"H => 2.07 sf x 7.12'L = 14.7 cf Overall Size= 34.0"W x 16.0"H x 7.56'L with 0.44' Overlap 66 Chambers in 6 Rows
#3	7.80'	137 cf	5.00'D x 7.00'H Vertical Cone/Cylinder
		2,201 cf	Total Available Storage

Storage Group A created with Chamber Wizard

Device	Routing	Invert	Outlet Devices
#1	Discarded	7.80'	1.020 in/hr Exfiltration over Surface area Conductivity to Groundwater Elevation = 5.80'
#2	Primary	8.10'	10.0" Round Culvert L= 10.0' CPP, square edge headwall, Ke= 0.500 Inlet / Outlet Invert= 8.10' / 8.00' S= 0.0100 '/ Cc= 0.900 n= 0.012 Corrugated PP, smooth interior, Flow Area= 0.55 sf
#3	Device 2	9.40'	5.0' long Sharp-Crested Rectangular Weir 2 End Contraction(s)

Discarded OutFlow Max=0.08 cfs @ 12.69 hrs HW=9.44' (Free Discharge)
 ↑1=Exfiltration (Controls 0.08 cfs)

Primary OutFlow Max=0.13 cfs @ 12.69 hrs HW=9.44' (Free Discharge)
 ↑2=Culvert (Passes 0.13 cfs of 2.51 cfs potential flow)
 ↑3=Sharp-Crested Rectangular Weir (Weir Controls 0.13 cfs @ 0.65 fps)

14850_Proposed-Drainage-Areas_220609

NOAA 24-hr C NOAA 10-yr Rainfall=5.02"

Prepared by {enter your company name here}

Printed 6/16/2022

HydroCAD® 10.10-7a s/n 00546 © 2021 HydroCAD Software Solutions LLC

Page 38

Pond INF-1: INFILTRATION SYSTEM #1 - Chamber Wizard Field A

Chamber Model = ADS_StormTechSC-310 +Cap (ADS StormTech®SC-310 with cap length)

Effective Size= 28.9"W x 16.0"H => 2.07 sf x 7.12'L = 14.7 cf

Overall Size= 34.0"W x 16.0"H x 7.56'L with 0.44' Overlap

34.0" Wide + 6.0" Spacing = 40.0" C-C Row Spacing

11 Chambers/Row x 7.12' Long +0.60' Cap Length x 2 = 79.52' Row Length +12.0" End Stone x 2 = 81.52' Base Length

6 Rows x 34.0" Wide + 6.0" Spacing x 5 + 12.0" Side Stone x 2 = 21.50' Base Width

6.0" Stone Base + 16.0" Chamber Height + 6.0" Stone Cover = 2.33' Field Height

66 Chambers x 14.7 cf = 973.0 cf Chamber Storage

4,089.6 cf Field - 973.0 cf Chambers = 3,116.6 cf Stone x 35.0% Voids = 1,090.8 cf Stone Storage

Chamber Storage + Stone Storage = 2,063.8 cf = 0.047 af

Overall Storage Efficiency = 50.5%

Overall System Size = 81.52' x 21.50' x 2.33'

66 Chambers
 151.5 cy Field
 115.4 cy Stone

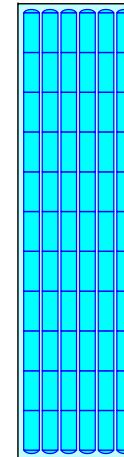

14850_Proposed-Drainage-Areas_220609

NOAA 24-hr C NOAA 10-yr Rainfall=5.02"

Prepared by {enter your company name here}

Printed 6/16/2022

HydroCAD® 10.10-7a s/n 00546 © 2021 HydroCAD Software Solutions LLC

Page 39

Summary for Pond INF-2: INFILTRATION SYSTEM #2

Inflow Area = 143,309 sf, 49.69% Impervious, Inflow Depth = 1.97" for NOAA 10-yr event
 Inflow = 2.93 cfs @ 12.13 hrs, Volume= 23,559 cf
 Outflow = 2.77 cfs @ 12.15 hrs, Volume= 23,559 cf, Atten= 5%, Lag= 1.5 min
 Discarded = 0.12 cfs @ 12.15 hrs, Volume= 9,228 cf
 Primary = 2.66 cfs @ 12.15 hrs, Volume= 14,332 cf
 Routed to Reach B : PARKING LOT B OVERFLOW

Routing by Stor-Ind method, Time Span= 0.00-72.00 hrs, dt= 0.05 hrs
 Peak Elev= 9.80' @ 12.15 hrs Surf.Area= 2,268 sf Storage= 3,428 cf

Plug-Flow detention time= 144.9 min calculated for 23,559 cf (100% of inflow)
 Center-of-Mass det. time= 144.8 min (1,009.1 - 864.3)

Volume	Invert	Avail.Storage	Storage Description
#1A	7.50'	1,790 cf	25.25'W x 89.06'L x 3.50'H Field A 7,870 cf Overall - 2,756 cf Embedded = 5,114 cf x 35.0% Voids
#2A	8.00'	2,756 cf	ADS_StormTech SC-740 +Cap x 60 Inside #1 Effective Size= 44.6"W x 30.0"H => 6.45 sf x 7.12'L = 45.9 cf Overall Size= 51.0"W x 30.0"H x 7.56'L with 0.44' Overlap 60 Chambers in 5 Rows
#3	7.50'	137 cf	5.00'D x 7.00'H Vertical Cone/Cylinder
		4,684 cf	Total Available Storage

Storage Group A created with Chamber Wizard

Device	Routing	Invert	Outlet Devices
#1	Discarded	7.50'	1.020 in/hr Exfiltration over Surface area Conductivity to Groundwater Elevation = 5.50'
#2	Primary	8.00'	10.0" Round Culvert L= 10.0' CPP, square edge headwall, Ke= 0.500 Inlet / Outlet Invert= 8.00' / 7.90' S= 0.0100 '/ Cc= 0.900 n= 0.012 Corrugated PP, smooth interior, Flow Area= 0.55 sf
#3	Device 2	9.50'	5.0' long Sharp-Crested Rectangular Weir 2 End Contraction(s)

Discarded OutFlow Max=0.12 cfs @ 12.15 hrs HW=9.80' (Free Discharge)
 ↳1=Exfiltration (Controls 0.12 cfs)

Primary OutFlow Max=2.62 cfs @ 12.15 hrs HW=9.80' (Free Discharge)
 ↳2=Culvert (Passes 2.62 cfs of 3.09 cfs potential flow)
 ↳3=Sharp-Crested Rectangular Weir(Weir Controls 2.62 cfs @ 1.78 fps)

14850_Proposed-Drainage-Areas_220609

NOAA 24-hr C NOAA 10-yr Rainfall=5.02"

Prepared by {enter your company name here}

Printed 6/16/2022

HydroCAD® 10.10-7a s/n 00546 © 2021 HydroCAD Software Solutions LLC

Page 40

Pond INF-2: INFILTRATION SYSTEM #2 - Chamber Wizard Field A

Chamber Model = ADS_StormTechSC-740 +Cap (ADS StormTech®SC-740 with cap length)

Effective Size= 44.6"W x 30.0"H => 6.45 sf x 7.12'L = 45.9 cf

Overall Size= 51.0"W x 30.0"H x 7.56'L with 0.44' Overlap

51.0" Wide + 6.0" Spacing = 57.0" C-C Row Spacing

12 Chambers/Row x 7.12' Long +0.81' Cap Length x 2 = 87.06' Row Length +12.0" End Stone x 2 = 89.06' Base Length

5 Rows x 51.0" Wide + 6.0" Spacing x 4 + 12.0" Side Stone x 2 = 25.25' Base Width

6.0" Stone Base + 30.0" Chamber Height + 6.0" Stone Cover = 3.50' Field Height

60 Chambers x 45.9 cf = 2,756.4 cf Chamber Storage

7,870.4 cf Field - 2,756.4 cf Chambers = 5,114.0 cf Stone x 35.0% Voids = 1,789.9 cf Stone Storage

Chamber Storage + Stone Storage = 4,546.3 cf = 0.104 af

Overall Storage Efficiency = 57.8%

Overall System Size = 89.06' x 25.25' x 3.50'

60 Chambers
 291.5 cy Field
 189.4 cy Stone

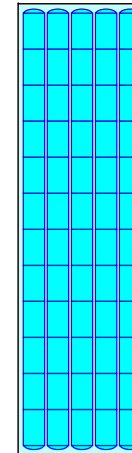

14850_Proposed-Drainage-Areas_220609

NOAA 24-hr C NOAA 10-yr Rainfall=5.02"

Prepared by {enter your company name here}

Printed 6/16/2022

HydroCAD® 10.10-7a s/n 00546 © 2021 HydroCAD Software Solutions LLC

Page 41

Summary for Pond INF3: INFILTRATION SYSTEM #1

Inflow Area = 19,743 sf, 50.83% Impervious, Inflow Depth = 2.96" for NOAA 10-yr event
 Inflow = 1.06 cfs @ 12.13 hrs, Volume= 4,862 cf
 Outflow = 1.05 cfs @ 12.14 hrs, Volume= 4,862 cf, Atten= 1%, Lag= 0.9 min
 Discarded = 0.05 cfs @ 12.14 hrs, Volume= 2,902 cf
 Primary = 1.00 cfs @ 12.14 hrs, Volume= 1,960 cf
 Routed to Reach P ST : PORTLAND STREET DRAINAGE

Routing by Stor-Ind method, Time Span= 0.00-72.00 hrs, dt= 0.05 hrs
 Peak Elev= 9.66' @ 12.14 hrs Surf.Area= 1,113 sf Storage= 991 cf

Plug-Flow detention time= 146.9 min calculated for 4,862 cf (100% of inflow)
 Center-of-Mass det. time= 146.7 min (968.0 - 821.3)

Volume	Invert	Avail.Storage	Storage Description
#1A	8.10'	686 cf	18.17'W x 60.16'L x 2.33'H Field A 2,550 cf Overall - 590 cf Embedded = 1,960 cf x 35.0% Voids
#2A	8.60'	590 cf	ADS_StormTech SC-310 +Cap x 40 Inside #1 Effective Size= 28.9"W x 16.0"H => 2.07 sf x 7.12'L = 14.7 cf Overall Size= 34.0"W x 16.0"H x 7.56'L with 0.44' Overlap 40 Chambers in 5 Rows
#3	8.10'	137 cf	5.00'D x 7.00'H Vertical Cone/Cylinder
		1,413 cf	Total Available Storage

Storage Group A created with Chamber Wizard

Device	Routing	Invert	Outlet Devices
#1	Discarded	8.10'	1.020 in/hr Exfiltration over Surface area Conductivity to Groundwater Elevation = 6.10'
#2	Primary	8.40'	10.0" Round Culvert L= 10.0' CPP, square edge headwall, Ke= 0.500 Inlet / Outlet Invert= 8.40' / 8.30' S= 0.0100 '/ Cc= 0.900 n= 0.012 Corrugated PP, smooth interior, Flow Area= 0.55 sf
#3	Device 2	9.50'	5.0' long Sharp-Crested Rectangular Weir 2 End Contraction(s)

Discarded OutFlow Max=0.05 cfs @ 12.14 hrs HW=9.65' (Free Discharge)
 1=Exfiltration (Controls 0.05 cfs)

Primary OutFlow Max=0.98 cfs @ 12.14 hrs HW=9.65' (Free Discharge)
 2=Culvert (Passes 0.98 cfs of 2.33 cfs potential flow)
 3=Sharp-Crested Rectangular Weir(Weir Controls 0.98 cfs @ 1.28 fps)

14850_Proposed-Drainage-Areas_220609

NOAA 24-hr C NOAA 10-yr Rainfall=5.02"

Prepared by {enter your company name here}

Printed 6/16/2022

HydroCAD® 10.10-7a s/n 00546 © 2021 HydroCAD Software Solutions LLC

Page 42

Pond INF3: INFILTRATION SYSTEM #1 - Chamber Wizard Field A

Chamber Model = ADS_StormTechSC-310 +Cap (ADS StormTech®SC-310 with cap length)

Effective Size= 28.9"W x 16.0"H => 2.07 sf x 7.12'L = 14.7 cf

Overall Size= 34.0"W x 16.0"H x 7.56'L with 0.44' Overlap

34.0" Wide + 6.0" Spacing = 40.0" C-C Row Spacing

8 Chambers/Row x 7.12' Long +0.60' Cap Length x 2 = 58.16' Row Length +12.0" End Stone x 2 = 60.16' Base Length

5 Rows x 34.0" Wide + 6.0" Spacing x 4 + 12.0" Side Stone x 2 = 18.17' Base Width

6.0" Stone Base + 16.0" Chamber Height + 6.0" Stone Cover = 2.33' Field Height

40 Chambers x 14.7 cf = 589.7 cf Chamber Storage

2,550.1 cf Field - 589.7 cf Chambers = 1,960.4 cf Stone x 35.0% Voids = 686.2 cf Stone Storage

Chamber Storage + Stone Storage = 1,275.8 cf = 0.029 af

Overall Storage Efficiency = 50.0%

Overall System Size = 60.16' x 18.17' x 2.33'

40 Chambers
 94.4 cy Field
 72.6 cy Stone

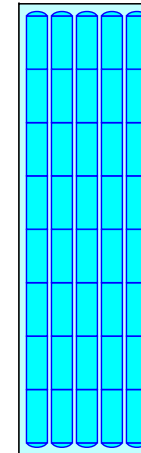

14850_Proposed-Drainage-Areas_220609

NOAA 24-hr C NOAA 100-yr Rainfall=7.59"

Prepared by {enter your company name here}

Printed 6/16/2022

HydroCAD@ 10.10-7a s/n 00546 © 2021 HydroCAD Software Solutions LLC

Page 43

Time span=0.00-72.00 hrs, dt=0.05 hrs, 1441 points
 Runoff by SCS TR-20 method, UH=SCS, Weighted-CN
 Reach routing by Stor-Ind+Trans method - Pond routing by Stor-Ind method

Pond 1-P: BB 1 Peak Elev=10.27' Storage=1,114 cf Inflow=6.35 cfs 19,201 cf
 Discarded=0.05 cfs 2,860 cf Primary=4.04 cfs 3,321 cf Secondary=2.54 cfs 13,021 cf Outflow=6.64 cfs 19,201 cf

Pond 2a-P: BB 2a Peak Elev=9.41' Storage=274 cf Inflow=0.56 cfs 1,847 cf
 Primary=0.52 cfs 721 cf Secondary=0.03 cfs 1,126 cf Outflow=0.55 cfs 1,847 cf

Pond 2b-P: BB 2b Peak Elev=8.59' Storage=326 cf Inflow=3.78 cfs 12,099 cf
 Primary=2.94 cfs 11,892 cf Secondary=0.83 cfs 207 cf Outflow=3.77 cfs 12,099 cf

Pond 3A-P: BB 3A Peak Elev=11.14' Storage=511 cf Inflow=1.84 cfs 5,647 cf
 Discarded=0.03 cfs 1,537 cf Primary=1.73 cfs 4,110 cf Outflow=1.75 cfs 5,647 cf

Pond 3B-P: BB 3B Peak Elev=12.91' Storage=263 cf Inflow=0.80 cfs 2,559 cf
 Discarded=0.02 cfs 983 cf Primary=0.80 cfs 1,576 cf Outflow=0.82 cfs 2,559 cf

Pond 4A-P: BB 4A - POND Peak Elev=10.09' Storage=253 cf Inflow=0.86 cfs 2,822 cf
 Primary=0.80 cfs 1,349 cf Secondary=0.04 cfs 1,473 cf Outflow=0.84 cfs 2,822 cf

Pond 4A-S: BB4A-Stone Peak Elev=7.13' Storage=26 cf Inflow=0.04 cfs 1,473 cf
 Outflow=0.04 cfs 1,456 cf

Pond 4B-P: BB 4B - POND Peak Elev=11.06' Storage=142 cf Inflow=0.54 cfs 1,776 cf
 Primary=0.52 cfs 858 cf Secondary=0.02 cfs 919 cf Outflow=0.54 cfs 1,776 cf

Pond 4B-S: BB 4A-Stone Peak Elev=7.85' Storage=15 cf Inflow=0.02 cfs 919 cf
 Outflow=0.02 cfs 908 cf

Pond 5A-P: BB 5A - POND Peak Elev=9.58' Storage=472 cf Inflow=0.54 cfs 1,699 cf
 Primary=0.32 cfs 278 cf Secondary=0.05 cfs 1,422 cf Outflow=0.37 cfs 1,699 cf

Pond 5A-PS: BB 5A-Stone Peak Elev=5.95' Storage=57 cf Inflow=0.05 cfs 1,422 cf
 Outflow=0.05 cfs 1,386 cf

Pond 5B-P: BB 5B - POND Peak Elev=9.15' Storage=711 cf Inflow=6.01 cfs 18,883 cf
 Primary=3.58 cfs 2,563 cf Secondary=0.10 cfs 4,817 cf Tertiary=2.58 cfs 11,504 cf Outflow=6.26 cfs 18,883 cf

Pond 5B-PS: BB 5B-Stone Peak Elev=5.47' Storage=96 cf Inflow=0.10 cfs 4,817 cf
 Outflow=0.09 cfs 4,765 cf

Pond 6A-P: BB 6A - POND Peak Elev=11.07' Storage=469 cf Inflow=2.44 cfs 7,345 cf
 Primary=2.38 cfs 4,859 cf Secondary=0.05 cfs 2,486 cf Outflow=2.43 cfs 7,345 cf

Pond 6A-PS: BB 6A - STONE Peak Elev=7.40' Storage=34 cf Inflow=0.05 cfs 2,486 cf
 Outflow=0.05 cfs 2,464 cf

Pond 6B-P: BB 6B Peak Elev=12.13' Storage=394 cf Inflow=1.14 cfs 3,657 cf
 Discarded=0.02 cfs 1,294 cf Primary=1.15 cfs 2,363 cf Outflow=1.17 cfs 3,657 cf

14850_Proposed-Drainage-Areas_220609

NOAA 24-hr C NOAA 100-yr Rainfall=7.59"

Prepared by {enter your company name here}

Printed 6/16/2022

HydroCAD@ 10.10-7a s/n 00546 © 2021 HydroCAD Software Solutions LLC

Page 44

Pond 7A-P: BB 7A PONDING Peak Elev=10.01' Storage=159 cf Inflow=0.56 cfs 1,844 cf
 Primary=0.54 cfs 916 cf Secondary=0.02 cfs 928 cf Outflow=0.56 cfs 1,844 cf

Pond 7A-S: BB 7A - STONE Peak Elev=5.19' Storage=4 cf Inflow=0.02 cfs 928 cf
 Outflow=0.02 cfs 928 cf

Pond 7B-P: BB 7B PONDING Peak Elev=10.75' Storage=295 cf Inflow=0.88 cfs 2,880 cf
 Primary=0.82 cfs 1,369 cf Secondary=0.04 cfs 1,511 cf Outflow=0.86 cfs 2,880 cf

Pond 7B-S: BB 7B - STONE Peak Elev=7.62' Storage=17 cf Inflow=0.04 cfs 1,511 cf
 Outflow=0.04 cfs 1,500 cf

Pond 8a-P: BB 8A PONDING Peak Elev=9.12' Storage=308 cf Inflow=0.70 cfs 2,240 cf
 Primary=0.64 cfs 855 cf Secondary=0.04 cfs 1,385 cf Outflow=0.68 cfs 2,240 cf

Pond 8a-s: BB 8A - STONE Peak Elev=5.63' Storage=30 cf Inflow=0.04 cfs 1,385 cf
 Outflow=0.04 cfs 1,367 cf

Pond 8B-P: BB 8B-PONDING Peak Elev=9.75' Storage=274 cf Inflow=1.00 cfs 3,262 cf
 Primary=0.94 cfs 1,582 cf Secondary=0.04 cfs 1,680 cf Outflow=0.98 cfs 3,262 cf

Pond 8B-S: BB 8B-Stone Peak Elev=6.33' Storage=39 cf Inflow=0.04 cfs 1,680 cf
 Outflow=0.04 cfs 1,653 cf

Pond 9-P: BB9 - POND Peak Elev=9.09' Storage=485 cf Inflow=5.18 cfs 16,401 cf
 Primary=2.30 cfs 1,149 cf Secondary=0.05 cfs 2,475 cf Tertiary=2.93 cfs 12,777 cf Outflow=5.28 cfs 16,401 cf

Pond 9-PS: BB9 - STONE Peak Elev=5.40' Storage=23 cf Inflow=0.05 cfs 2,475 cf
 Outflow=0.05 cfs 2,461 cf

Pond 14P: BB2A-Stone Peak Elev=5.61' Storage=6 cf Inflow=0.03 cfs 1,126 cf
 Outflow=0.03 cfs 1,126 cf

Pond DMH1: DIVERSION MANHOLE - SEYMOUR ST Peak Elev=10.10' Inflow=3.28 cfs 10,065 cf
 Primary=0.87 cfs 7,068 cf Secondary=2.41 cfs 2,996 cf Outflow=3.28 cfs 10,065 cf

Pond DMH2: DIVERSION MANHOLE - HUDSON STREET Peak Elev=35.73' Inflow=23.44 cfs 70,873 cf
 Primary=4.74 cfs 35,221 cf Secondary=18.70 cfs 35,651 cf Outflow=23.44 cfs 70,873 cf

Pond DMH3: DIVERSION MANHOLE - PORTLAND ST Peak Elev=12.07' Inflow=3.23 cfs 9,764 cf
 Primary=1.44 cfs 7,738 cf Secondary=1.78 cfs 2,026 cf Outflow=3.23 cfs 9,764 cf

Pond INF-1: INFILTRATIONSYSTEM#1 Peak Elev=9.53' Storage=1,727 cf Inflow=0.87 cfs 7,068 cf
 Discarded=0.08 cfs 5,184 cf Primary=0.82 cfs 1,885 cf Outflow=0.89 cfs 7,068 cf

Pond INF-2: INFILTRATIONSYSTEM#2 Peak Elev=10.13' Storage=3,861 cf Inflow=4.74 cfs 35,221 cf
 Discarded=0.12 cfs 10,022 cf Primary=3.44 cfs 25,199 cf Outflow=3.57 cfs 35,221 cf

Pond INF3: INFILTRATIONSYSTEM#1 Peak Elev=9.69' Storage=1,012 cf Inflow=1.44 cfs 7,738 cf
 Discarded=0.05 cfs 3,496 cf Primary=1.39 cfs 4,242 cf Outflow=1.43 cfs 7,738 cf

Summary for Pond 1-P: BB 1

[93] Warning: Storage range exceeded by 0.07'
 [88] Warning: Qout>Qin may require smaller dt or Finer Routing

Inflow Area = 38,826 sf, 51.66% Impervious, Inflow Depth = 5.93" for NOAA 100-yr event
 Inflow = 6.35 cfs @ 12.13 hrs, Volume= 19,201 cf
 Outflow = 6.64 cfs @ 12.14 hrs, Volume= 19,201 cf, Atten= 0%, Lag= 0.8 min
 Discarded = 0.05 cfs @ 12.13 hrs, Volume= 2,860 cf
 Primary = 4.04 cfs @ 12.14 hrs, Volume= 3,321 cf
 Routed to Reach 17R : Rodney French Pipe
 Secondary = 2.54 cfs @ 12.14 hrs, Volume= 13,021 cf
 Routed to Reach 15R : ISOLATOR ROW 1

Routing by Stor-Ind method, Time Span= 0.00-72.00 hrs, dt= 0.05 hrs
 Peak Elev= 10.27' @ 12.14 hrs Surf.Area= 1,830 sf Storage= 1,114 cf

Plug-Flow detention time= 36.1 min calculated for 19,188 cf (100% of inflow)
 Center-of-Mass det. time= 36.4 min (828.3 - 792.0)

Volume	Invert	Avail.Storage	Storage Description
#1	9.20'	1,114 cf	Custom Stage Data (Prismatic) Listed below (Recalc)
Elevation (feet)	Surf.Area (sq-ft)	Inc.Store (cubic-feet)	Cum.Store (cubic-feet)
9.20	490	0	0
9.50	800	194	194
10.20	1,830	920	1,114

Device	Routing	Invert	Outlet Devices
#1	Primary	8.00'	12.0" Round Culvert L= 10.0' CPP, square edge headwall, Ke= 0.500 Inlet / Outlet Invert= 8.00' / 7.90' S= 0.0100 '/' Cc= 0.900 n= 0.013, Flow Area= 0.79 sf
#2	Discarded	9.20'	1.020 in/hr Exfiltration over Surface area Conductivity to Groundwater Elevation = 6.00'
#3	Device 1	10.00'	24inch-Dome Grate Capacity X 2.00
#4	Secondary	9.83'	15inch-Dome Grate Capacity

Discarded OutFlow Max=0.05 cfs @ 12.13 hrs HW=10.25' (Free Discharge)
 ↳2=Exfiltration (Controls 0.05 cfs)

Primary OutFlow Max=3.81 cfs @ 12.14 hrs HW=10.26' (Free Discharge)
 ↳1=Culvert (Passes 3.81 cfs of 5.01 cfs potential flow)
 ↳3=24inch-Dome Grate Capacity (Custom Controls 3.81 cfs)

Secondary OutFlow Max=2.51 cfs @ 12.14 hrs HW=10.26' (Free Discharge)
 ↳4=15inch-Dome Grate Capacity (Custom Controls 2.51 cfs)

Summary for Pond 2a-P: BB 2a

Inflow Area = 3,116 sf, 92.62% Impervious, Inflow Depth = 7.11" for NOAA 100-yr event
 Inflow = 0.56 cfs @ 12.13 hrs, Volume= 1,847 cf
 Outflow = 0.55 cfs @ 12.14 hrs, Volume= 1,847 cf, Atten= 1%, Lag= 1.1 min
 Primary = 0.52 cfs @ 12.14 hrs, Volume= 721 cf
 Routed to Reach DP-1 : French Rodney Blvd Outfall
 Secondary = 0.03 cfs @ 12.14 hrs, Volume= 1,126 cf
 Routed to Pond 14P : BB2A-Stone

Routing by Stor-Ind method, Time Span= 0.00-72.00 hrs, dt= 0.05 hrs
 Peak Elev= 9.41' @ 12.14 hrs Surf.Area= 425 sf Storage= 274 cf

Plug-Flow detention time= 54.8 min calculated for 1,847 cf (100% of inflow)
 Center-of-Mass det. time= 54.8 min (809.2 - 754.4)

Volume	Invert	Avail.Storage	Storage Description
#1	8.50'	462 cf	Custom Stage Data (Prismatic) Listed below (Recalc)
Elevation (feet)	Surf.Area (sq-ft)	Inc.Store (cubic-feet)	Cum.Store (cubic-feet)
8.50	180	0	0
9.80	530	462	462

Device	Routing	Invert	Outlet Devices
#1	Primary	7.80'	10.0" Round Culvert L= 10.0' CPP, square edge headwall, Ke= 0.500 Inlet / Outlet Invert= 7.80' / 7.70' S= 0.0100 '/' Cc= 0.900 n= 0.013, Flow Area= 0.55 sf
#2	Device 1	9.30'	24inch-Dome Grate Capacity
#3	Secondary	8.50'	2.410 in/hr Exfiltration over Surface area Conductivity to Groundwater Elevation = 4.60'

Primary OutFlow Max=0.51 cfs @ 12.14 hrs HW=9.41' (Free Discharge)
 ↳1=Culvert (Passes 0.51 cfs of 2.86 cfs potential flow)
 ↳2=24inch-Dome Grate Capacity (Custom Controls 0.51 cfs)

Secondary OutFlow Max=0.03 cfs @ 12.14 hrs HW=9.41' (Free Discharge)
 ↳3=Exfiltration (Controls 0.03 cfs)

14850_Proposed-Drainage-Areas_220609

NOAA 24-hr C NOAA 100-yr Rainfall=7.59"

Prepared by {enter your company name here}

Printed 6/16/2022

HydroCAD® 10.10-7a s/n 00546 © 2021 HydroCAD Software Solutions LLC

Page 47

Summary for Pond 2b-P: BB 2b

Inflow Area = 21,490 sf, 80.50% Impervious, Inflow Depth = 6.76" for NOAA 100-yr event
 Inflow = 3.78 cfs @ 12.13 hrs, Volume= 12,099 cf
 Outflow = 3.77 cfs @ 12.15 hrs, Volume= 12,099 cf, Atten= 0%, Lag= 1.4 min
 Primary = 2.94 cfs @ 12.15 hrs, Volume= 11,892 cf
 Routed to Reach 15R : ISOLATOR ROW 1
 Secondary = 0.83 cfs @ 12.15 hrs, Volume= 207 cf
 Routed to Reach DP-1 : French Rodney Blvd Outfall

Routing by Stor-Ind method, Time Span= 0.00-72.00 hrs, dt= 0.05 hrs
 Peak Elev= 8.59' @ 12.15 hrs Surf.Area= 781 sf Storage= 326 cf

Plug-Flow detention time= 1.7 min calculated for 12,099 cf (100% of inflow)
 Center-of-Mass det. time= 1.7 min (770.0 - 768.3)

Volume	Invert	Avail.Storage	Storage Description
#1	8.00'	710 cf	Custom Stage Data (Prismatic) Listed below (Recalc)
Elevation (feet)	Surf.Area (sq-ft)	Inc.Store (cubic-feet)	Cum.Store (cubic-feet)
8.00	320	0	0
9.00	1,100	710	710

Device	Routing	Invert	Outlet Devices
#1	Secondary	7.00'	12.0" Round Culvert L= 10.0' CPP, square edge headwall, Ke= 0.500 Inlet / Outlet Invert= 7.00' / 6.90' S= 0.0100 '/ Cc= 0.900 n= 0.013, Flow Area= 0.79 sf
#2	Device 1	8.50'	24inch-Dome Grate Capacity X 2.00
#3	Primary	8.00'	15inch-Dome Grate Capacity

Primary OutFlow Max=2.94 cfs @ 12.15 hrs HW=8.59' (Free Discharge)
 ↳3=15inch-Dome Grate Capacity (Custom Controls 2.94 cfs)

Secondary OutFlow Max=0.82 cfs @ 12.15 hrs HW=8.59' (Free Discharge)
 ↳1=Culvert (Passes 0.82 cfs of 3.89 cfs potential flow)
 ↳2=24inch-Dome Grate Capacity (Custom Controls 0.82 cfs)

14850_Proposed-Drainage-Areas_220609

NOAA 24-hr C NOAA 100-yr Rainfall=7.59"

Prepared by {enter your company name here}

Printed 6/16/2022

HydroCAD® 10.10-7a s/n 00546 © 2021 HydroCAD Software Solutions LLC

Page 48

Summary for Pond 3A-P: BB 3A

Inflow Area = 10,987 sf, 58.16% Impervious, Inflow Depth = 6.17" for NOAA 100-yr event
 Inflow = 1.84 cfs @ 12.13 hrs, Volume= 5,647 cf
 Outflow = 1.75 cfs @ 12.15 hrs, Volume= 5,647 cf, Atten= 5%, Lag= 1.3 min
 Discarded = 0.03 cfs @ 12.15 hrs, Volume= 1,537 cf
 Primary = 1.73 cfs @ 12.15 hrs, Volume= 4,110 cf
 Routed to Reach BMP_3 : BMP-3_OVERFLOW

Routing by Stor-Ind method, Time Span= 0.00-72.00 hrs, dt= 0.05 hrs
 Peak Elev= 11.14' @ 12.15 hrs Surf.Area= 953 sf Storage= 511 cf

Plug-Flow detention time= 61.6 min calculated for 5,647 cf (100% of inflow)
 Center-of-Mass det. time= 61.5 min (847.5 - 786.0)

Volume	Invert	Avail.Storage	Storage Description
#1	10.25'	622 cf	Custom Stage Data (Prismatic) Listed below (Recalc)
Elevation (feet)	Surf.Area (sq-ft)	Inc.Store (cubic-feet)	Cum.Store (cubic-feet)
10.25	271	0	0
10.45	350	62	62
11.25	1,050	560	622

Device	Routing	Invert	Outlet Devices
#1	Primary	9.30'	10.0" Round Culvert L= 10.0' CPP, square edge headwall, Ke= 0.500 Inlet / Outlet Invert= 9.30' / 9.20' S= 0.0100 '/ Cc= 0.900 n= 0.013, Flow Area= 0.55 sf
#2	Discarded	10.25'	1.020 in/hr Exfiltration over Surface area Conductivity to Groundwater Elevation = 7.30'
#3	Primary	11.15'	5.0' long Sharp-Crested Rectangular Weir 2 End Contraction(s)
#4	Device 1	10.90'	24inch-Dome Grate Capacity

Discarded OutFlow Max=0.03 cfs @ 12.15 hrs HW=11.14' (Free Discharge)
 ↳2=Exfiltration (Controls 0.03 cfs)

Primary OutFlow Max=1.73 cfs @ 12.15 hrs HW=11.14' (Free Discharge)
 ↳1=Culvert (Passes 1.73 cfs of 3.13 cfs potential flow)
 ↳4=24inch-Dome Grate Capacity (Custom Controls 1.73 cfs)
 ↳3=Sharp-Crested Rectangular Weir (Controls 0.00 cfs)

Summary for Pond 3B-P: BB 3B

[93] Warning: Storage range exceeded by 0.01'
 [88] Warning: Qout>Qin may require smaller dt or Finer Routing

Inflow Area = 4,545 sf, 77.34% Impervious, Inflow Depth = 6.76" for NOAA 100-yr event
 Inflow = 0.80 cfs @ 12.13 hrs, Volume= 2,559 cf
 Outflow = 0.82 cfs @ 12.14 hrs, Volume= 2,559 cf, Atten= 0%, Lag= 0.6 min
 Discarded = 0.02 cfs @ 12.13 hrs, Volume= 983 cf
 Primary = 0.80 cfs @ 12.14 hrs, Volume= 1,576 cf
 Routed to Reach BMP_3 : BMP-3_OVERFLOW

Routing by Stor-Ind method, Time Span= 0.00-72.00 hrs, dt= 0.05 hrs
 Peak Elev= 12.91' @ 12.14 hrs Surf.Area= 570 sf Storage= 263 cf

Plug-Flow detention time= 80.1 min calculated for 2,559 cf (100% of inflow)
 Center-of-Mass det. time= 80.1 min (848.3 - 768.3)

Volume	Invert	Avail.Storage	Storage Description
#1	12.20'	263 cf	Custom Stage Data (Prismatic) Listed below (Recalc)
Elevation (feet)	Surf.Area (sq-ft)	Inc.Store (cubic-feet)	Cum.Store (cubic-feet)
12.20	180	0	0
12.90	570	263	263

Device	Routing	Invert	Outlet Devices
#1	Primary	10.70'	10.0" Round Culvert L= 10.0' CPP, square edge headwall, Ke= 0.500 Inlet / Outlet Invert= 10.70' / 10.60' S= 0.0100 '/ Cc= 0.900 n= 0.013, Flow Area= 0.55 sf
#2	Discarded	12.20'	1.020 in/hr Exfiltration over Surface area Conductivity to Groundwater Elevation = 8.70'
#3	Device 1	12.80'	24inch-Dome Grate Capacity
#4	Primary	12.85'	5.0' long Sharp-Crested Rectangular Weir 2 End Contraction(s)

Discarded OutFlow Max=0.02 cfs @ 12.13 hrs HW=12.91' (Free Discharge)
 ↳2=Exfiltration (Controls 0.02 cfs)

Primary OutFlow Max=0.77 cfs @ 12.14 hrs HW=12.91' (Free Discharge)
 ↳1=Culvert (Passes 0.53 cfs of 3.52 cfs potential flow)
 ↳3=24inch-Dome Grate Capacity (Custom Controls 0.53 cfs)
 ↳4=Sharp-Crested Rectangular Weir (Weir Controls 0.24 cfs @ 0.80 fps)

Summary for Pond 4A-P: BB 4A - POND

Inflow Area = 4,843 sf, 86.37% Impervious, Inflow Depth = 6.99" for NOAA 100-yr event
 Inflow = 0.86 cfs @ 12.13 hrs, Volume= 2,822 cf
 Outflow = 0.84 cfs @ 12.14 hrs, Volume= 2,822 cf, Atten= 3%, Lag= 1.1 min
 Primary = 0.80 cfs @ 12.14 hrs, Volume= 1,349 cf
 Routed to Reach BMP_3 : BMP-3_OVERFLOW
 Secondary = 0.04 cfs @ 12.14 hrs, Volume= 1,473 cf
 Routed to Pond 4A-S : BB4A-Store

Routing by Stor-Ind method, Time Span= 0.00-72.00 hrs, dt= 0.05 hrs
 Peak Elev= 10.09' @ 12.14 hrs Surf.Area= 601 sf Storage= 253 cf

Plug-Flow detention time= 29.0 min calculated for 2,820 cf (100% of inflow)
 Center-of-Mass det. time= 29.0 min (788.4 - 759.4)

Volume	Invert	Avail.Storage	Storage Description
#1	9.50'	320 cf	Custom Stage Data (Prismatic) Listed below (Recalc)
Elevation (feet)	Surf.Area (sq-ft)	Inc.Store (cubic-feet)	Cum.Store (cubic-feet)
9.50	250	0	0
10.20	664	320	320

Device	Routing	Invert	Outlet Devices
#1	Primary	8.00'	12.0" Round Culvert L= 10.0' CPP, square edge headwall, Ke= 0.500 Inlet / Outlet Invert= 8.00' / 7.90' S= 0.0100 '/ Cc= 0.900 n= 0.013, Flow Area= 0.79 sf
#2	Secondary	9.50'	2.410 in/hr Exfiltration over Surface area Conductivity to Groundwater Elevation = 6.00'
#3	Primary	10.10'	5.0' long Sharp-Crested Rectangular Weir 2 End Contraction(s)
#4	Device 1	9.95'	24inchDome Grate Capacity Head (feet) 0.00 0.05 0.10 0.15 0.20 0.25 0.30 0.35 0.40 0.45 0.50 0.55 0.60 0.65 0.70 0.75 0.80 0.85 0.90 0.95 1.00 1.05 1.10 Disch. (cfs) 0.000 0.180 0.460 0.850 1.360 1.830 2.420 3.100 3.600 3.800 4.000 4.200 4.380 4.600 4.750 4.900 5.100 5.200 5.350 5.450 5.650 5.800 5.950

Primary OutFlow Max=0.79 cfs @ 12.14 hrs HW=10.09' (Free Discharge)
 ↳1=Culvert (Passes 0.79 cfs of 4.77 cfs potential flow)
 ↳4=24inchDome Grate Capacity (Custom Controls 0.79 cfs)
 ↳3=Sharp-Crested Rectangular Weir (Controls 0.00 cfs)

Secondary OutFlow Max=0.04 cfs @ 12.14 hrs HW=10.09' (Free Discharge)
 ↳2=Exfiltration (Controls 0.04 cfs)

14850_Proposed-Drainage-Areas_220609

NOAA 24-hr C NOAA 100-yr Rainfall=7.59"

Prepared by {enter your company name here}

Printed 6/16/2022

HydroCAD® 10.10-7a s/n 00546 © 2021 HydroCAD Software Solutions LLC

Page 51

Summary for Pond 4A-S: BB4A-Stone

Inflow = 0.04 cfs @ 12.14 hrs, Volume= 1,473 cf
 Outflow = 0.04 cfs @ 12.18 hrs, Volume= 1,456 cf, Atten= 1%, Lag= 2.0 min
 Primary = 0.04 cfs @ 12.18 hrs, Volume= 1,456 cf
 Routed to Reach BMP4_O : BMP-4 OVERFLOW

Routing by Stor-Ind method, Time Span= 0.00-72.00 hrs, dt= 0.05 hrs
 Peak Elev= 7.13' @ 12.18 hrs Surf.Area= 230 sf Storage= 26 cf

Plug-Flow detention time= 20.3 min calculated for 1,455 cf (99% of inflow)
 Center-of-Mass det. time= 13.3 min (851.7 - 838.5)

Volume	Invert	Avail.Storage	Storage Description
#1	6.75'	138 cf	Custom Stage Data (Prismatic) Listed below (Recalc) 460 cf Overall x 30.0% Voids

Elevation (feet)	Surf.Area (sq-ft)	Inc.Store (cubic-feet)	Cum.Store (cubic-feet)
6.75	230	0	0
8.75	230	460	460

Device	Routing	Invert	Outlet Devices
#1	Primary	7.00'	4.0" Vert. Orifice/Grate C= 0.600 Limited to weir flow at low heads

Primary OutFlow Max=0.04 cfs @ 12.18 hrs HW=7.13' (Free Discharge)
 ↳ **1=Orifice/Grate** (Orifice Controls 0.04 cfs @ 1.21 fps)

14850_Proposed-Drainage-Areas_220609

NOAA 24-hr C NOAA 100-yr Rainfall=7.59"

Prepared by {enter your company name here}

Printed 6/16/2022

HydroCAD® 10.10-7a s/n 00546 © 2021 HydroCAD Software Solutions LLC

Page 52

Summary for Pond 4B-P: BB 4B - POND

Inflow Area = 3,048 sf, 86.09% Impervious, Inflow Depth = 6.99" for NOAA 100-yr event
 Inflow = 0.54 cfs @ 12.13 hrs, Volume= 1,776 cf
 Outflow = 0.54 cfs @ 12.14 hrs, Volume= 1,776 cf, Atten= 1%, Lag= 1.0 min
 Primary = 0.52 cfs @ 12.14 hrs, Volume= 858 cf
 Routed to Reach BMP4_O : BMP-4 OVERFLOW
 Secondary = 0.02 cfs @ 12.14 hrs, Volume= 919 cf
 Routed to Pond 4B-S : BB 4A-Stone

Routing by Stor-Ind method, Time Span= 0.00-72.00 hrs, dt= 0.05 hrs
 Peak Elev= 11.06' @ 12.14 hrs Surf.Area= 367 sf Storage= 142 cf

Plug-Flow detention time= 28.5 min calculated for 1,775 cf (100% of inflow)
 Center-of-Mass det. time= 28.5 min (787.9 - 759.4)

Volume	Invert	Avail.Storage	Storage Description
#1	10.50'	199 cf	Custom Stage Data (Prismatic) Listed below (Recalc)

Elevation (feet)	Surf.Area (sq-ft)	Inc.Store (cubic-feet)	Cum.Store (cubic-feet)
10.50	144	0	0
11.20	424	199	199

Device	Routing	Invert	Outlet Devices
#1	Primary	9.00'	12.0" Round Culvert L= 10.0' CPP, square edge headwall, Ke= 0.500 Inlet / Outlet Invert= 9.00' / 8.90' S= 0.0100 '/ Cc= 0.900 n= 0.013, Flow Area= 0.79 sf
#2	Secondary	10.50'	2.410 in/hr Exfiltration over Surface area Conductivity to Groundwater Elevation = 7.00'
#3	Primary	11.10'	5.0' long Sharp-Crested Rectangular Weir 2 End Contraction(s)
#4	Device 1	10.95'	24inch-Dome Grate Capacity

Primary OutFlow Max=0.50 cfs @ 12.14 hrs HW=11.06' (Free Discharge)
 ↳ **1=Culvert** (Passes 0.50 cfs of 4.72 cfs potential flow)
 ↳ **4=24inch-Dome Grate Capacity** (Custom Controls 0.50 cfs)
 ↳ **3=Sharp-Crested Rectangular Weir** (Controls 0.00 cfs)

Secondary OutFlow Max=0.02 cfs @ 12.14 hrs HW=11.06' (Free Discharge)
 ↳ **2=Exfiltration** (Controls 0.02 cfs)

14850_Proposed-Drainage-Areas_220609

NOAA 24-hr C NOAA 100-yr Rainfall=7.59"

Prepared by {enter your company name here}

Printed 6/16/2022

HydroCAD® 10.10-7a s/n 00546 © 2021 HydroCAD Software Solutions LLC

Page 53

Summary for Pond 4B-S: BB 4A-Stone

Inflow = 0.02 cfs @ 12.14 hrs, Volume= 919 cf
 Outflow = 0.02 cfs @ 12.16 hrs, Volume= 908 cf, Atten= 1%, Lag= 1.4 min
 Primary = 0.02 cfs @ 12.16 hrs, Volume= 908 cf
 Routed to Reach BMP4_O : BMP-4 OVERFLOW

Routing by Stor-Ind method, Time Span= 0.00-72.00 hrs, dt= 0.05 hrs
 Peak Elev= 7.85' @ 12.16 hrs Surf.Area= 145 sf Storage= 15 cf

Plug-Flow detention time= 19.6 min calculated for 908 cf (99% of inflow)
 Center-of-Mass det. time= 12.3 min (851.5 - 839.3)

Volume	Invert	Avail.Storage	Storage Description
#1	7.50'	87 cf	Custom Stage Data (Prismatic) Listed below (Recalc) 290 cf Overall x 30.0% Voids

Elevation (feet)	Surf.Area (sq-ft)	Inc.Store (cubic-feet)	Cum.Store (cubic-feet)
7.50	145	0	0
9.50	145	290	290

Device	Routing	Invert	Outlet Devices
#1	Primary	7.75'	4.0" Vert. Orifice/Grate C= 0.600 Limited to weir flow at low heads

Primary OutFlow Max=0.02 cfs @ 12.16 hrs HW=7.85' (Free Discharge)
 ↑**1=Orifice/Grate** (Orifice Controls 0.02 cfs @ 1.06 fps)

14850_Proposed-Drainage-Areas_220609

NOAA 24-hr C NOAA 100-yr Rainfall=7.59"

Prepared by {enter your company name here}

Printed 6/16/2022

HydroCAD® 10.10-7a s/n 00546 © 2021 HydroCAD Software Solutions LLC

Page 54

Summary for Pond 5A-P: BB 5A - POND

Inflow Area = 3,072 sf, 73.44% Impervious, Inflow Depth = 6.64" for NOAA 100-yr event
 Inflow = 0.54 cfs @ 12.13 hrs, Volume= 1,699 cf
 Outflow = 0.37 cfs @ 12.22 hrs, Volume= 1,699 cf, Atten= 31%, Lag= 5.4 min
 Primary = 0.32 cfs @ 12.22 hrs, Volume= 278 cf
 Routed to Reach B : PARKING LOT B OVERFLOW
 Secondary = 0.05 cfs @ 12.22 hrs, Volume= 1,422 cf
 Routed to Pond 5A-PS : BB 5A-Stone

Routing by Stor-Ind method, Time Span= 0.00-72.00 hrs, dt= 0.05 hrs
 Peak Elev= 9.58' @ 12.22 hrs Surf.Area= 736 sf Storage= 472 cf

Plug-Flow detention time= 61.4 min calculated for 1,698 cf (100% of inflow)
 Center-of-Mass det. time= 61.4 min (833.6 - 772.2)

Volume	Invert	Avail.Storage	Storage Description
#1	8.80'	645 cf	Custom Stage Data (Prismatic) Listed below (Recalc)

Elevation (feet)	Surf.Area (sq-ft)	Inc.Store (cubic-feet)	Cum.Store (cubic-feet)
8.80	480	0	0
9.80	810	645	645

Device	Routing	Invert	Outlet Devices
#1	Primary	7.60'	12.0" Round Culvert L= 10.0' CPP, square edge headwall, Ke= 0.500 Inlet / Outlet Invert= 7.60' / 7.50' S= 0.0100 '/' Cc= 0.900 n= 0.013, Flow Area= 0.79 sf
#2	Secondary	8.80'	2.410 in/hr Exfiltration over Surface area Conductivity to Groundwater Elevation = 5.60'
#3	Device 1	9.50'	24inch-Dome Grate Capacity

Primary OutFlow Max=0.29 cfs @ 12.22 hrs HW=9.57' (Free Discharge)
 ↑**1=Culvert** (Passes 0.29 cfs of 4.58 cfs potential flow)
 ↑**3=24inch-Dome Grate Capacity**(Custom Controls 0.29 cfs)

Secondary OutFlow Max=0.05 cfs @ 12.22 hrs HW=9.57' (Free Discharge)
 ↑**2=Exfiltration** (Controls 0.05 cfs)

14850_Proposed-Drainage-Areas_220609

NOAA 24-hr C NOAA 100-yr Rainfall=7.59"

Prepared by {enter your company name here}

Printed 6/16/2022

HydroCAD® 10.10-7a s/n 00546 © 2021 HydroCAD Software Solutions LLC

Page 55

Summary for Pond 5A-PS: BB 5A-Stone

Inflow = 0.05 cfs @ 12.22 hrs, Volume= 1,422 cf
 Outflow = 0.05 cfs @ 12.34 hrs, Volume= 1,386 cf, Atten= 2%, Lag= 7.5 min
 Primary = 0.05 cfs @ 12.34 hrs, Volume= 1,386 cf
 Routed to Reach B : PARKING LOT B OVERFLOW

Routing by Stor-Ind method, Time Span= 0.00-72.00 hrs, dt= 0.05 hrs
 Peak Elev= 5.95' @ 12.34 hrs Surf.Area= 480 sf Storage= 57 cf

Plug-Flow detention time= 38.7 min calculated for 1,385 cf (97% of inflow)
 Center-of-Mass det. time= 24.7 min (876.2 - 851.5)

Volume	Invert	Avail.Storage	Storage Description
#1	5.55'	288 cf	Custom Stage Data (Prismatic) Listed below (Recalc) 960 cf Overall x 30.0% Voids

Elevation (feet)	Surf.Area (sq-ft)	Inc.Store (cubic-feet)	Cum.Store (cubic-feet)
5.55	480	0	0
7.55	480	960	960

Device	Routing	Invert	Outlet Devices
#1	Primary	5.80'	4.0" Vert. Orifice/Grate C= 0.600 Limited to weir flow at low heads

Primary OutFlow Max=0.05 cfs @ 12.34 hrs HW=5.95' (Free Discharge)
 ←1=Orifice/Grate (Orifice Controls 0.05 cfs @ 1.30 fps)

14850_Proposed-Drainage-Areas_220609

NOAA 24-hr C NOAA 100-yr Rainfall=7.59"

Prepared by {enter your company name here}

Printed 6/16/2022

HydroCAD® 10.10-7a s/n 00546 © 2021 HydroCAD Software Solutions LLC

Page 56

Summary for Pond 5B-P: BB 5B - POND

[93] Warning: Storage range exceeded by 0.15'
 [88] Warning: Qout>Qin may require smaller dt or Finer Routing

Inflow Area = 34,755 sf, 71.39% Impervious, Inflow Depth = 6.52" for NOAA 100-yr event
 Inflow = 6.01 cfs @ 12.13 hrs, Volume= 18,883 cf
 Outflow = 6.26 cfs @ 12.14 hrs, Volume= 18,883 cf, Atten= 0%, Lag= 0.6 min
 Primary = 3.58 cfs @ 12.14 hrs, Volume= 2,563 cf
 Routed to Reach B : PARKING LOT B OVERFLOW
 Secondary = 0.10 cfs @ 12.14 hrs, Volume= 4,817 cf
 Routed to Pond 5B-PS : BB 5B-Stone
 Tertiary = 2.58 cfs @ 12.14 hrs, Volume= 11,504 cf
 Routed to Reach 6R : ISOLATOR ROW 2

Routing by Stor-Ind method, Time Span= 0.00-72.00 hrs, dt= 0.05 hrs
 Peak Elev= 9.15' @ 12.14 hrs Surf.Area= 1,450 sf Storage= 711 cf

Plug-Flow detention time= 22.3 min calculated for 18,883 cf (100% of inflow)
 Center-of-Mass det. time= 22.3 min (798.2 - 775.9)

Volume	Invert	Avail.Storage	Storage Description
#1	8.20'	711 cf	Custom Stage Data (Prismatic) Listed below (Recalc)

Elevation (feet)	Surf.Area (sq-ft)	Inc.Store (cubic-feet)	Cum.Store (cubic-feet)
8.20	327	0	0
9.00	1,450	711	711

Device	Routing	Invert	Outlet Devices
#1	Primary	7.00'	12.0" Round Culvert L= 10.0' CPP, square edge headwall, Ke= 0.500 Inlet / Outlet Invert= 7.00' / 6.90' S= 0.0100 '/ Cc= 0.900 n= 0.013, Flow Area= 0.79 sf
#2	Secondary	8.20'	2.410 in/hr Exfiltration over Surface area Conductivity to Groundwater Elevation = 5.00'
#3	Device 1	8.90'	24inchDome Grate Capacity X 2.00 Head (feet) 0.00 0.05 0.10 0.15 0.20 0.25 0.30 0.35 0.40 0.45 0.50 0.55 0.60 0.65 0.70 0.75 0.80 0.85 0.90 0.95 1.00 1.05 1.10 Disch. (cfs) 0.000 0.180 0.460 0.850 1.360 1.830 2.420 3.100 3.600 3.800 4.000 4.200 4.380 4.600 4.750 4.900 5.100 5.200 5.350 5.450 5.650 5.800 5.950
#4	Tertiary	8.70'	15inch-Dome Grate Capacity

Primary OutFlow Max=3.31 cfs @ 12.14 hrs HW=9.13' (Free Discharge)
 ↳1=Culvert (Passes 3.31 cfs of 4.83 cfs potential flow)
 ↳3=24inchDome Grate Capacity (Custom Controls 3.31 cfs)

Secondary OutFlow Max=0.10 cfs @ 12.14 hrs HW=9.13' (Free Discharge)
 ↳2=Exfiltration (Controls 0.10 cfs)

Tertiary OutFlow Max=2.53 cfs @ 12.14 hrs HW=9.13' (Free Discharge)
 ↳4=15inch-Dome Grate Capacity (Custom Controls 2.53 cfs)

Summary for Pond 5B-PS: BB 5B-Stone

Inflow = 0.10 cfs @ 12.14 hrs, Volume= 4,817 cf
 Outflow = 0.09 cfs @ 12.19 hrs, Volume= 4,765 cf, Atten= 2%, Lag= 3.2 min
 Primary = 0.09 cfs @ 12.19 hrs, Volume= 4,765 cf
 Routed to Reach B : PARKING LOT B OVERFLOW

Routing by Stor-Ind method, Time Span= 0.00-72.00 hrs, dt= 0.05 hrs
 Peak Elev= 5.47' @ 12.19 hrs Surf.Area= 690 sf Storage= 96 cf

Plug-Flow detention time= 24.3 min calculated for 4,762 cf (99% of inflow)
 Center-of-Mass det. time= 17.5 min (939.7 - 922.2)

Volume	Invert	Avail.Storage	Storage Description
#1	5.00'	414 cf	Custom Stage Data (Prismatic) Listed below (Recalc) 1,380 cf Overall x 30.0% Voids

Elevation (feet)	Surf.Area (sq-ft)	Inc.Store (cubic-feet)	Cum.Store (cubic-feet)
5.00	690	0	0
7.00	690	1,380	1,380

Device	Routing	Invert	Outlet Devices
#1	Primary	5.25'	4.0" Vert. Orifice/Grate C= 0.600 Limited to weir flow at low heads

Primary OutFlow Max=0.09 cfs @ 12.19 hrs HW=5.47' (Free Discharge)
 ↳1=Orifice/Grate (Orifice Controls 0.09 cfs @ 1.58 fps)

14850_Proposed-Drainage-Areas_220609

NOAA 24-hr C NOAA 100-yr Rainfall=7.59"

Prepared by {enter your company name here}

Printed 6/16/2022

HydroCAD® 10.10-7a s/n 00546 © 2021 HydroCAD Software Solutions LLC

Page 59

Summary for Pond 6A-P: BB 6A - POND

Inflow Area = 15,148 sf, 46.97% Impervious, Inflow Depth = 5.82" for NOAA 100-yr event
 Inflow = 2.44 cfs @ 12.13 hrs, Volume= 7,345 cf
 Outflow = 2.43 cfs @ 12.14 hrs, Volume= 7,345 cf, Atten= 0%, Lag= 0.8 min
 Primary = 2.38 cfs @ 12.14 hrs, Volume= 4,859 cf
 Routed to Reach BMP6_O : BMP-6 OVERFLOW
 Secondary = 0.05 cfs @ 12.14 hrs, Volume= 2,486 cf
 Routed to Pond 6A-PS : BB 6A - STONE

Routing by Stor-Ind method, Time Span= 0.00-72.00 hrs, dt= 0.05 hrs
 Peak Elev= 11.07' @ 12.14 hrs Surf.Area= 727 sf Storage= 469 cf

Plug-Flow detention time= 35.4 min calculated for 7,345 cf (100% of inflow)
 Center-of-Mass det. time= 35.3 min (830.1 - 794.8)

Volume	Invert	Avail.Storage	Storage Description
#1	10.20'	491 cf	Custom Stage Data (Prismatic) Listed below (Recalc)
Elevation (feet)	Surf.Area (sq-ft)	Inc.Store (cubic-feet)	Cum.Store (cubic-feet)
10.20	350	0	0
11.10	740	491	491

Device	Routing	Invert	Outlet Devices
#1	Primary	9.00'	12.0" Round Culvert L= 10.0' CPP, square edge headwall, Ke= 0.500 Inlet / Outlet Invert= 9.00' / 8.90' S= 0.0100 1' Cc= 0.900 n= 0.013, Flow Area= 0.79 sf
#2	Secondary	10.20'	2.410 in/hr Exfiltration over Surface area Conductivity to Groundwater Elevation = 7.00'
#3	Device 1	10.80'	24inch-Dome Grate Capacity
#4	Primary	11.00'	5.0' long Sharp-Crested Rectangular Weir 2 End Contraction(s)

Primary OutFlow Max=2.32 cfs @ 12.14 hrs HW=11.07' (Free Discharge)

1=Culvert (Passes 2.04 cfs of 4.73 cfs potential flow)

3=24inch-Dome Grate Capacity (Custom Controls 2.04 cfs)

4=Sharp-Crested Rectangular Weir (Weir Controls 0.29 cfs @ 0.85 fps)

Secondary OutFlow Max=0.05 cfs @ 12.14 hrs HW=11.07' (Free Discharge)

2=Exfiltration (Controls 0.05 cfs)

14850_Proposed-Drainage-Areas_220609

NOAA 24-hr C NOAA 100-yr Rainfall=7.59"

Prepared by {enter your company name here}

Printed 6/16/2022

HydroCAD® 10.10-7a s/n 00546 © 2021 HydroCAD Software Solutions LLC

Page 60

Summary for Pond 6A-PS: BB 6A - STONE

Inflow = 0.05 cfs @ 12.14 hrs, Volume= 2,486 cf
 Outflow = 0.05 cfs @ 12.18 hrs, Volume= 2,464 cf, Atten= 1%, Lag= 2.1 min
 Primary = 0.05 cfs @ 12.18 hrs, Volume= 2,464 cf
 Routed to Reach BMP6_O : BMP-6 OVERFLOW

Routing by Stor-Ind method, Time Span= 0.00-72.00 hrs, dt= 0.05 hrs
 Peak Elev= 7.40' @ 12.18 hrs Surf.Area= 290 sf Storage= 34 cf

Plug-Flow detention time= 16.8 min calculated for 2,464 cf (99% of inflow)
 Center-of-Mass det. time= 11.2 min (998.0 - 986.8)

Volume	Invert	Avail.Storage	Storage Description
#1	7.00'	174 cf	Custom Stage Data (Prismatic) Listed below (Recalc) 580 cf Overall x 30.0% Voids

Elevation (feet)	Surf.Area (sq-ft)	Inc.Store (cubic-feet)	Cum.Store (cubic-feet)
7.00	290	0	0
9.00	290	580	580

Device	Routing	Invert	Outlet Devices
#1	Primary	7.25'	4.0" Vert. Orifice/Grate C= 0.600 Limited to weir flow at low heads

Primary OutFlow Max=0.05 cfs @ 12.18 hrs HW=7.40' (Free Discharge)

1=Orifice/Grate (Orifice Controls 0.05 cfs @ 1.30 fps)

14850_Proposed-Drainage-Areas_220609

NOAA 24-hr C NOAA 100-yr Rainfall=7.59"

Prepared by {enter your company name here}

Printed 6/16/2022

HydroCAD® 10.10-7a s/n 00546 © 2021 HydroCAD Software Solutions LLC

Page 61

Summary for Pond 6B-P: BB 6B

[93] Warning: Storage range exceeded by 0.03'

[88] Warning: Qout>Qin may require smaller dt or Finer Routing

Inflow Area = 6,495 sf, 77.45% Impervious, Inflow Depth = 6.76" for NOAA 100-yr event
 Inflow = 1.14 cfs @ 12.13 hrs, Volume= 3,657 cf
 Outflow = 1.17 cfs @ 12.14 hrs, Volume= 3,657 cf, Atten= 0%, Lag= 0.6 min
 Discarded = 0.02 cfs @ 12.13 hrs, Volume= 1,294 cf
 Primary = 1.15 cfs @ 12.14 hrs, Volume= 2,363 cf
 Routed to Reach BMP6_O : BMP-6 OVERFLOW

Routing by Stor-Ind method, Time Span= 0.00-72.00 hrs, dt= 0.05 hrs
 Peak Elev= 12.13' @ 12.14 hrs Surf.Area= 690 sf Storage= 394 cf

Plug-Flow detention time= 88.5 min calculated for 3,654 cf (100% of inflow)
 Center-of-Mass det. time= 88.7 min (857.0 - 768.3)

Volume	Invert	Avail.Storage	Storage Description
#1	11.20'	394 cf	Custom Stage Data (Prismatic) Listed below (Recalc)
Elevation (feet)	Surf.Area (sq-ft)	Inc.Store (cubic-feet)	Cum.Store (cubic-feet)
11.20	185	0	0
12.10	690	394	394

Device	Routing	Invert	Outlet Devices
#1	Primary	10.10'	12.0" Round Culvert L= 10.0' CPP, square edge headwall, Ke= 0.500 Inlet / Outlet Invert= 10.10' / 10.00' S= 0.0100 ' / Cc= 0.900 n= 0.013, Flow Area= 0.79 sf
#2	Discarded	11.20'	1.020 in/hr Exfiltration over Surface area Conductivity to Groundwater Elevation = 8.10'
#3	Device 1	11.95'	24inch-Dome Grate Capacity

Discarded OutFlow Max=0.02 cfs @ 12.13 hrs HW=12.12' (Free Discharge)
 ↳2=Exfiltration (Controls 0.02 cfs)

Primary OutFlow Max=1.10 cfs @ 12.14 hrs HW=12.12' (Free Discharge)
 ↳1=Culvert (Passes 1.10 cfs of 4.67 cfs potential flow)
 ↳3=24inch-Dome Grate Capacity (Custom Controls 1.10 cfs)

14850_Proposed-Drainage-Areas_220609

NOAA 24-hr C NOAA 100-yr Rainfall=7.59"

Prepared by {enter your company name here}

Printed 6/16/2022

HydroCAD® 10.10-7a s/n 00546 © 2021 HydroCAD Software Solutions LLC

Page 62

Summary for Pond 7A-P: BB 7A PONDING

Inflow Area = 3,165 sf, 87.74% Impervious, Inflow Depth = 6.99" for NOAA 100-yr event
 Inflow = 0.56 cfs @ 12.13 hrs, Volume= 1,844 cf
 Outflow = 0.56 cfs @ 12.14 hrs, Volume= 1,844 cf, Atten= 0%, Lag= 0.9 min
 Primary = 0.54 cfs @ 12.14 hrs, Volume= 916 cf
 Routed to Reach 7R : PARKING LOT C to HUDSON
 Secondary = 0.02 cfs @ 12.14 hrs, Volume= 928 cf
 Routed to Pond 7A-S : BB 7A - STONE

Routing by Stor-Ind method, Time Span= 0.00-72.00 hrs, dt= 0.05 hrs
 Peak Elev= 10.01' @ 12.14 hrs Surf.Area= 332 sf Storage= 159 cf

Plug-Flow detention time= 37.5 min calculated for 1,843 cf (100% of inflow)
 Center-of-Mass det. time= 37.5 min (796.9 - 759.4)

Volume	Invert	Avail.Storage	Storage Description
#1	9.30'	227 cf	Custom Stage Data (Prismatic) Listed below (Recalc)
Elevation (feet)	Surf.Area (sq-ft)	Inc.Store (cubic-feet)	Cum.Store (cubic-feet)
9.30	115	0	0
10.20	390	227	227

Device	Routing	Invert	Outlet Devices
#1	Primary	8.10'	12.0" Round Culvert L= 10.0' CPP, square edge headwall, Ke= 0.500 Inlet / Outlet Invert= 8.10' / 8.00' S= 0.0100 ' / Cc= 0.900 n= 0.013, Flow Area= 0.79 sf
#2	Secondary	9.30'	2.410 in/hr Exfiltration over Surface area Conductivity to Groundwater Elevation = 6.10'
#3	Device 1	9.90'	24inch-Dome Grate Capacity
#4	Primary	10.10'	5.0' long Sharp-Crested Rectangular Weir 2 End Contraction(s)

Primary OutFlow Max=0.53 cfs @ 12.14 hrs HW=10.01' (Free Discharge)
 ↳1=Culvert (Passes 0.53 cfs of 4.49 cfs potential flow)
 ↳3=24inch-Dome Grate Capacity (Custom Controls 0.53 cfs)
 ↳4=Sharp-Crested Rectangular Weir (Controls 0.00 cfs)

Secondary OutFlow Max=0.02 cfs @ 12.14 hrs HW=10.01' (Free Discharge)
 ↳2=Exfiltration (Controls 0.02 cfs)

14850_Proposed-Drainage-Areas_220609

NOAA 24-hr C NOAA 100-yr Rainfall=7.59"

Prepared by {enter your company name here}

Printed 6/16/2022

HydroCAD® 10.10-7a s/n 00546 © 2021 HydroCAD Software Solutions LLC

Page 63

Summary for Pond 7A-S: BB 7A - STONE

Inflow = 0.02 cfs @ 12.14 hrs, Volume= 928 cf
 Outflow = 0.02 cfs @ 12.16 hrs, Volume= 928 cf, Atten= 1%, Lag= 1.5 min
 Primary = 0.02 cfs @ 12.16 hrs, Volume= 928 cf
 Routed to Reach 7R : PARKING LOT C to HUDSON

Routing by Stor-Ind method, Time Span= 0.00-72.00 hrs, dt= 0.05 hrs
 Peak Elev= 5.19' @ 12.16 hrs Surf.Area= 150 sf Storage= 4 cf

Plug-Flow detention time= 4.3 min calculated for 928 cf (100% of inflow)
 Center-of-Mass det. time= 4.3 min (863.7 - 859.3)

Volume	Invert	Avail.Storage	Storage Description
#1	5.10'	90 cf	Custom Stage Data (Prismatic) Listed below (Recalc) 300 cf Overall x 30.0% Voids

Elevation (feet)	Surf.Area (sq-ft)	Inc.Store (cubic-feet)	Cum.Store (cubic-feet)
5.10	150	0	0
7.10	150	300	300

Device	Routing	Invert	Outlet Devices
#1	Primary	5.10'	4.0" Vert. Orifice/Grate C= 0.600 Limited to weir flow at low heads

Primary OutFlow Max=0.02 cfs @ 12.16 hrs HW=5.19' (Free Discharge)
 ↑**1=Orifice/Grate** (Orifice Controls 0.02 cfs @ 1.04 fps)

14850_Proposed-Drainage-Areas_220609

NOAA 24-hr C NOAA 100-yr Rainfall=7.59"

Prepared by {enter your company name here}

Printed 6/16/2022

HydroCAD® 10.10-7a s/n 00546 © 2021 HydroCAD Software Solutions LLC

Page 64

Summary for Pond 7B-P: BB 7B PONDING

Inflow Area = 4,942 sf, 88.73% Impervious, Inflow Depth = 6.99" for NOAA 100-yr event
 Inflow = 0.88 cfs @ 12.13 hrs, Volume= 2,880 cf
 Outflow = 0.86 cfs @ 12.14 hrs, Volume= 2,880 cf, Atten= 2%, Lag= 1.0 min
 Primary = 0.82 cfs @ 12.14 hrs, Volume= 1,369 cf
 Routed to Reach BMP7_O : BMP-7 OVERFLOW
 Secondary = 0.04 cfs @ 12.14 hrs, Volume= 1,511 cf
 Routed to Pond 7B-S : BB 7B - STONE

Routing by Stor-Ind method, Time Span= 0.00-72.00 hrs, dt= 0.05 hrs
 Peak Elev= 10.75' @ 12.14 hrs Surf.Area= 539 sf Storage= 295 cf

Plug-Flow detention time= 38.8 min calculated for 2,878 cf (100% of inflow)
 Center-of-Mass det. time= 38.8 min (798.3 - 759.4)

Volume	Invert	Avail.Storage	Storage Description
#1	10.00'	324 cf	Custom Stage Data (Prismatic) Listed below (Recalc)

Elevation (feet)	Surf.Area (sq-ft)	Inc.Store (cubic-feet)	Cum.Store (cubic-feet)
10.00	250	0	0
10.80	560	324	324

Device	Routing	Invert	Outlet Devices
#1	Primary	8.90'	12.0" Round Culvert L= 10.0' CPP, square edge headwall, Ke= 0.500 Inlet / Outlet Invert= 8.90' / 8.80' S= 0.0100 '/ Cc= 0.900 n= 0.013, Flow Area= 0.79 sf
#2	Secondary	10.00'	2.410 in/hr Exfiltration over Surface area Conductivity to Groundwater Elevation = 6.90'
#3	Device 1	10.60'	24inch-Dome Grate Capacity

Primary OutFlow Max=0.81 cfs @ 12.14 hrs HW=10.74' (Free Discharge)
 ↑**1=Culvert** (Passes 0.81 cfs of 4.39 cfs potential flow)
 ↑**3=24inch-Dome Grate Capacity**(Custom Controls 0.81 cfs)

Secondary OutFlow Max=0.04 cfs @ 12.14 hrs HW=10.74' (Free Discharge)
 ↑**2=Exfiltration** (Controls 0.04 cfs)

14850_Proposed-Drainage-Areas_220609

NOAA 24-hr C NOAA 100-yr Rainfall=7.59"

Prepared by {enter your company name here}

Printed 6/16/2022

HydroCAD® 10.10-7a s/n 00546 © 2021 HydroCAD Software Solutions LLC

Page 65

Summary for Pond 7B-S: BB 7B - STONE

Inflow = 0.04 cfs @ 12.14 hrs, Volume= 1,511 cf
 Outflow = 0.04 cfs @ 12.16 hrs, Volume= 1,500 cf, Atten= 0%, Lag= 1.3 min
 Primary = 0.04 cfs @ 12.16 hrs, Volume= 1,500 cf
 Routed to Reach BMP7_O : BMP-7 OVERFLOW

Routing by Stor-Ind method, Time Span= 0.00-72.00 hrs, dt= 0.05 hrs
 Peak Elev= 7.62' @ 12.16 hrs Surf.Area= 150 sf Storage= 17 cf

Plug-Flow detention time= 13.3 min calculated for 1,500 cf (99% of inflow)
 Center-of-Mass det. time= 8.7 min (864.2 - 855.4)

Volume	Invert	Avail.Storage	Storage Description
#1	7.25'	90 cf	Custom Stage Data (Prismatic) Listed below (Recalc) 300 cf Overall x 30.0% Voids

Elevation (feet)	Surf.Area (sq-ft)	Inc.Store (cubic-feet)	Cum.Store (cubic-feet)
7.25	150	0	0
9.25	150	300	300

Device	Routing	Invert	Outlet Devices
#1	Primary	7.50'	4.0" Vert. Orifice/Grate C= 0.600 Limited to weir flow at low heads

Primary OutFlow Max=0.03 cfs @ 12.16 hrs HW=7.62' (Free Discharge)
 ↳ **1=Orifice/Grate** (Orifice Controls 0.03 cfs @ 1.19 fps)

14850_Proposed-Drainage-Areas_220609

NOAA 24-hr C NOAA 100-yr Rainfall=7.59"

Prepared by {enter your company name here}

Printed 6/16/2022

HydroCAD® 10.10-7a s/n 00546 © 2021 HydroCAD Software Solutions LLC

Page 66

Summary for Pond 8a-P: BB 8A PONDING

Inflow Area = 3,978 sf, 79.99% Impervious, Inflow Depth = 6.76" for NOAA 100-yr event
 Inflow = 0.70 cfs @ 12.13 hrs, Volume= 2,240 cf
 Outflow = 0.68 cfs @ 12.15 hrs, Volume= 2,240 cf, Atten= 3%, Lag= 1.3 min
 Primary = 0.64 cfs @ 12.15 hrs, Volume= 855 cf
 Routed to Reach P ST : PORTLAND STREET DRAINAGE
 Secondary = 0.04 cfs @ 12.15 hrs, Volume= 1,385 cf
 Routed to Pond 8a-s : BB 8A - STONE

Routing by Stor-Ind method, Time Span= 0.00-72.00 hrs, dt= 0.05 hrs
 Peak Elev= 9.12' @ 12.15 hrs Surf.Area= 628 sf Storage= 308 cf

Plug-Flow detention time= 35.0 min calculated for 2,240 cf (100% of inflow)
 Center-of-Mass det. time= 35.0 min (803.3 - 768.3)

Volume	Invert	Avail.Storage	Storage Description
#1	8.50'	575 cf	Custom Stage Data (Prismatic) Listed below (Recalc)

Elevation (feet)	Surf.Area (sq-ft)	Inc.Store (cubic-feet)	Cum.Store (cubic-feet)
8.50	360	0	0
9.50	790	575	575

Device	Routing	Invert	Outlet Devices
#1	Primary	7.40'	12.0" Round Culvert L= 10.0' CPP, square edge headwall, Ke= 0.500 Inlet / Outlet Invert= 7.40' / 7.30' S= 0.0100 '/ S= 0.0100 '/ Cc= 0.900 n= 0.013, Flow Area= 0.79 sf
#2	Secondary	8.50'	2.410 in/hr Exfiltration over Surface area Conductivity to Groundwater Elevation = 5.40'
#3	Device 1	9.00'	24inch-Dome Grate Capacity
#4	Primary	9.40'	5.0' long Sharp-Crested Rectangular Weir 2 End Contraction(s)

Primary OutFlow Max=0.63 cfs @ 12.15 hrs HW=9.12' (Free Discharge)
 ↳ **1=Culvert** (Passes 0.63 cfs of 4.18 cfs potential flow)
 ↳ **3=24inch-Dome Grate Capacity** (Custom Controls 0.63 cfs)
 ↳ **4=Sharp-Crested Rectangular Weir** (Controls 0.00 cfs)

Secondary OutFlow Max=0.04 cfs @ 12.15 hrs HW=9.12' (Free Discharge)
 ↳ **2=Exfiltration** (Controls 0.04 cfs)

14850_Proposed-Drainage-Areas_220609

NOAA 24-hr C NOAA 100-yr Rainfall=7.59"

Prepared by {enter your company name here}

Printed 6/16/2022

HydroCAD® 10.10-7a s/n 00546 © 2021 HydroCAD Software Solutions LLC

Page 67

Summary for Pond 8a-s: BB 8A - STONE

Inflow = 0.04 cfs @ 12.15 hrs, Volume= 1,385 cf
 Outflow = 0.04 cfs @ 12.19 hrs, Volume= 1,367 cf, Atten= 1%, Lag= 2.4 min
 Primary = 0.04 cfs @ 12.19 hrs, Volume= 1,367 cf
 Routed to Reach P ST : PORTLAND STREET DRAINAGE

Routing by Stor-Ind method, Time Span= 0.00-72.00 hrs, dt= 0.05 hrs
 Peak Elev= 5.63' @ 12.19 hrs Surf.Area= 300 sf Storage= 30 cf

Plug-Flow detention time= 23.0 min calculated for 1,367 cf (99% of inflow)
 Center-of-Mass det. time= 15.1 min (859.9 - 844.7)

Volume	Invert	Avail.Storage	Storage Description
#1	5.30'	180 cf	Custom Stage Data (Prismatic) Listed below (Recalc) 600 cf Overall x 30.0% Voids

Elevation (feet)	Surf.Area (sq-ft)	Inc.Store (cubic-feet)	Cum.Store (cubic-feet)
5.30	300	0	0
7.30	300	600	600

Device	Routing	Invert	Outlet Devices
#1	Primary	5.50'	4.0" Vert. Orifice/Grate C= 0.600 Limited to weir flow at low heads

Primary OutFlow Max=0.04 cfs @ 12.19 hrs HW=5.63' (Free Discharge)
 ↑**1=Orifice/Grate** (Orifice Controls 0.04 cfs @ 1.24 fps)

14850_Proposed-Drainage-Areas_220609

NOAA 24-hr C NOAA 100-yr Rainfall=7.59"

Prepared by {enter your company name here}

Printed 6/16/2022

HydroCAD® 10.10-7a s/n 00546 © 2021 HydroCAD Software Solutions LLC

Page 68

Summary for Pond 8B-P: BB 8B-PONDING

Inflow Area = 5,598 sf, 87.78% Impervious, Inflow Depth = 6.99" for NOAA 100-yr event
 Inflow = 1.00 cfs @ 12.13 hrs, Volume= 3,262 cf
 Outflow = 0.98 cfs @ 12.14 hrs, Volume= 3,262 cf, Atten= 1%, Lag= 0.9 min
 Primary = 0.94 cfs @ 12.14 hrs, Volume= 1,582 cf
 Routed to Reach 7R : PARKING LOT C to HUDSON

Secondary = 0.04 cfs @ 12.14 hrs, Volume= 1,680 cf
 Routed to Pond 8B-S : BB 8B-Stone

Routing by Stor-Ind method, Time Span= 0.00-72.00 hrs, dt= 0.05 hrs
 Peak Elev= 9.75' @ 12.14 hrs Surf.Area= 651 sf Storage= 274 cf

Plug-Flow detention time= 34.0 min calculated for 3,260 cf (100% of inflow)
 Center-of-Mass det. time= 34.0 min (793.4 - 759.4)

Volume	Invert	Avail.Storage	Storage Description
#1	9.10'	306 cf	Custom Stage Data (Prismatic) Listed below (Recalc)

Elevation (feet)	Surf.Area (sq-ft)	Inc.Store (cubic-feet)	Cum.Store (cubic-feet)
9.10	190	0	0
9.80	685	306	306

Device	Routing	Invert	Outlet Devices
#1	Primary	7.90'	12.0" Round Culvert L= 10.0' CPP, square edge headwall, Ke= 0.500 Inlet / Outlet Invert= 7.90' / 7.80' S= 0.0100 '/ Cc= 0.900 n= 0.013, Flow Area= 0.79 sf
#2	Secondary	9.10'	2.410 in/hr Exfiltration over Surface area Conductivity to Groundwater Elevation = 5.90'
#3	Device 1	9.65'	24inch-Dome Grate Capacity X 2.00

Primary OutFlow Max=0.92 cfs @ 12.14 hrs HW=9.75' (Free Discharge)
 ↑**1=Culvert** (Passes 0.92 cfs of 4.39 cfs potential flow)
 ↑**3=24inch-Dome Grate Capacity**(Custom Controls 0.92 cfs)

Secondary OutFlow Max=0.04 cfs @ 12.14 hrs HW=9.75' (Free Discharge)
 ↑**2=Exfiltration** (Controls 0.04 cfs)

Summary for Pond 8B-S: BB 8B-Stone

Inflow = 0.04 cfs @ 12.14 hrs, Volume= 1,680 cf
 Outflow = 0.04 cfs @ 12.18 hrs, Volume= 1,653 cf, Atten= 1%, Lag= 2.2 min
 Primary = 0.04 cfs @ 12.18 hrs, Volume= 1,653 cf
 Routed to Reach 7R : PARKING LOT C to HUDSON

Routing by Stor-Ind method, Time Span= 0.00-72.00 hrs, dt= 0.05 hrs
 Peak Elev= 6.33' @ 12.18 hrs Surf.Area= 300 sf Storage= 39 cf

Plug-Flow detention time= 27.3 min calculated for 1,653 cf (98% of inflow)
 Center-of-Mass det. time= 17.5 min (867.9 - 850.5)

Volume	Invert	Avail.Storage	Storage Description
#1	5.90'	180 cf	Custom Stage Data (Prismatic) Listed below (Recalc) 600 cf Overall x 30.0% Voids

Elevation (feet)	Surf.Area (sq-ft)	Inc.Store (cubic-feet)	Cum.Store (cubic-feet)
5.90	300	0	0
7.90	300	600	600

Device	Routing	Invert	Outlet Devices
#1	Primary	6.20'	4.0" Vert. Orifice/Grate C= 0.600 Limited to weir flow at low heads

Primary OutFlow Max=0.04 cfs @ 12.18 hrs HW=6.33' (Free Discharge)
 ↳ **1=Orifice/Grate** (Orifice Controls 0.04 cfs @ 1.24 fps)

Summary for Pond 9-P: BB9 - POND

[93] Warning: Storage range exceeded by 0.09'
 [88] Warning: Qout>Qin may require smaller dt or Finer Routing

Inflow Area = 29,651 sf, 74.77% Impervious, Inflow Depth = 6.64" for NOAA 100-yr event
 Inflow = 5.18 cfs @ 12.13 hrs, Volume= 16,401 cf
 Outflow = 5.28 cfs @ 12.14 hrs, Volume= 16,401 cf, Atten= 0%, Lag= 0.6 min
 Primary = 2.30 cfs @ 12.14 hrs, Volume= 1,149 cf
 Routed to Reach BMP9_O : BMP-9 OVERFLOW
 Secondary = 0.05 cfs @ 12.13 hrs, Volume= 2,475 cf
 Routed to Pond 9-PS : BB9 - STONE
 Tertiary = 2.93 cfs @ 12.14 hrs, Volume= 12,777 cf
 Routed to Reach 1R : ISOLATOR ROW C

Routing by Stor-Ind method, Time Span= 0.00-72.00 hrs, dt= 0.05 hrs
 Peak Elev= 9.09' @ 12.13 hrs Surf.Area= 780 sf Storage= 485 cf

Plug-Flow detention time= 14.0 min calculated for 16,390 cf (100% of inflow)
 Center-of-Mass det. time= 14.1 min (786.3 - 772.2)

Volume	Invert	Avail.Storage	Storage Description
#1	8.00'	485 cf	Custom Stage Data (Prismatic) Listed below (Recalc)

Elevation (feet)	Surf.Area (sq-ft)	Inc.Store (cubic-feet)	Cum.Store (cubic-feet)
8.00	190	0	0
9.00	780	485	485

Device	Routing	Invert	Outlet Devices
#1	Primary	7.00'	12.0" Round Culvert L= 10.0' CPP, square edge headwall, Ke= 0.500 Inlet / Outlet Invert= 7.00' / 6.90' S= 0.0100 '/ Cc= 0.900 n= 0.013, Flow Area= 0.79 sf
#2	Secondary	8.00'	2.410 in/hr Exfiltration over Surface area Conductivity to Groundwater Elevation = 5.00'
#3	Device 1	8.80'	24inchDome Grate Capacity Head (feet) 0.00 0.05 0.10 0.15 0.20 0.25 0.30 0.35 0.40 0.45 0.50 0.55 0.60 0.65 0.70 0.75 0.80 0.85 0.90 0.95 1.00 1.05 1.10 Disch. (cfs) 0.000 0.180 0.460 0.850 1.360 1.830 2.420 3.100 3.600 3.800 4.000 4.200 4.380 4.600 4.750 4.900 5.100 5.200 5.350 5.450 5.650 5.800 5.950
#4	Tertiary	8.50'	15inch-Dome Grate Capacity

14850_Proposed-Drainage-Areas_220609

NOAA 24-hr C NOAA 100-yr Rainfall=7.59"

Prepared by {enter your company name here}

Printed 6/16/2022

HydroCAD® 10.10-7a s/n 00546 © 2021 HydroCAD Software Solutions LLC

Page 71

Primary OutFlow Max=2.12 cfs @ 12.14 hrs HW=9.07' (Free Discharge)

↳ **1=Culvert** (Passes 2.12 cfs of 4.75 cfs potential flow)

↳ **3=24inchDome Grate Capacity** (Custom Controls 2.12 cfs)

Secondary OutFlow Max=0.05 cfs @ 12.13 hrs HW=9.07' (Free Discharge)

↳ **2=Exfiltration** (Controls 0.05 cfs)

Tertiary OutFlow Max=2.89 cfs @ 12.14 hrs HW=9.08' (Free Discharge)

↳ **4=15inch-Dome Grate Capacity** (Custom Controls 2.89 cfs)

14850_Proposed-Drainage-Areas_220609

NOAA 24-hr C NOAA 100-yr Rainfall=7.59"

Prepared by {enter your company name here}

Printed 6/16/2022

HydroCAD® 10.10-7a s/n 00546 © 2021 HydroCAD Software Solutions LLC

Page 72

Summary for Pond 9-PS: BB9 - STONE

Inflow = 0.05 cfs @ 12.13 hrs, Volume= 2,475 cf
 Outflow = 0.05 cfs @ 12.16 hrs, Volume= 2,461 cf, Atten= 1%, Lag= 1.5 min
 Primary = 0.05 cfs @ 12.16 hrs, Volume= 2,461 cf
 Routed to Reach BMP9_O : BMP-9 OVERFLOW

Routing by Stor-Ind method, Time Span= 0.00-72.00 hrs, dt= 0.05 hrs
 Peak Elev= 5.40' @ 12.16 hrs Surf.Area= 190 sf Storage= 23 cf

Plug-Flow detention time= 11.8 min calculated for 2,459 cf (99% of inflow)
 Center-of-Mass det. time= 7.8 min (896.1 - 888.3)

Volume	Invert	Avail.Storage	Storage Description
#1	5.00'	114 cf	Custom Stage Data (Prismatic) Listed below (Recalc) 380 cf Overall x 30.0% Voids

Elevation (feet)	Surf.Area (sq-ft)	Inc.Store (cubic-feet)	Cum.Store (cubic-feet)
5.00	190	0	0
7.00	190	380	380

Device	Routing	Invert	Outlet Devices
#1	Primary	5.25'	4.0" Vert. Orifice/Grate C= 0.600 Limited to weir flow at low heads

Primary OutFlow Max=0.05 cfs @ 12.16 hrs HW=5.40' (Free Discharge)

↳ **1=Orifice/Grate** (Orifice Controls 0.05 cfs @ 1.34 fps)

14850_Proposed-Drainage-Areas_220609

NOAA 24-hr C NOAA 100-yr Rainfall=7.59"

Prepared by {enter your company name here}

Printed 6/16/2022

HydroCAD® 10.10-7a s/n 00546 © 2021 HydroCAD Software Solutions LLC

Page 73

Summary for Pond 14P: BB2A-Stone

Inflow = 0.03 cfs @ 12.14 hrs, Volume= 1,126 cf
 Outflow = 0.03 cfs @ 12.17 hrs, Volume= 1,126 cf, Atten= 0%, Lag= 1.6 min
 Primary = 0.03 cfs @ 12.17 hrs, Volume= 1,126 cf
 Routed to Reach DP-1 : French Rodney Blvd Outfall

Routing by Stor-Ind method, Time Span= 0.00-72.00 hrs, dt= 0.05 hrs
 Peak Elev= 5.61' @ 12.17 hrs Surf.Area= 180 sf Storage= 6 cf

Plug-Flow detention time= 4.7 min calculated for 1,125 cf (100% of inflow)
 Center-of-Mass det. time= 4.7 min (860.8 - 856.1)

Volume	Invert	Avail.Storage	Storage Description
#1	5.50'	108 cf	Custom Stage Data (Prismatic) Listed below (Recalc) 360 cf Overall x 30.0% Voids

Elevation (feet)	Surf.Area (sq-ft)	Inc.Store (cubic-feet)	Cum.Store (cubic-feet)
5.50	180	0	0
7.50	180	360	360

Device	Routing	Invert	Outlet Devices
#1	Primary	5.50'	4.0" Vert. Orifice/Grate C= 0.600 Limited to weir flow at low heads

Primary OutFlow Max=0.03 cfs @ 12.17 hrs HW=5.61' (Free Discharge)
 ↳1=Orifice/Grate (Orifice Controls 0.03 cfs @ 1.12 fps)

14850_Proposed-Drainage-Areas_220609

NOAA 24-hr C NOAA 100-yr Rainfall=7.59"

Prepared by {enter your company name here}

Printed 6/16/2022

HydroCAD® 10.10-7a s/n 00546 © 2021 HydroCAD Software Solutions LLC

Page 74

Summary for Pond DMH1: DIVERSION MANHOLE - SEYMOUR ST

[57] Hint: Peaked at 10.10' (Flood elevation advised)

Inflow Area = 19,582 sf, 58.17% Impervious, Inflow Depth = 6.17" for NOAA 100-yr event
 Inflow = 3.28 cfs @ 12.13 hrs, Volume= 10,065 cf
 Outflow = 3.28 cfs @ 12.13 hrs, Volume= 10,065 cf, Atten= 0%, Lag= 0.0 min
 Primary = 0.87 cfs @ 12.13 hrs, Volume= 7,068 cf
 Routed to Pond INF-1 : INFILTRATION SYSTEM #1
 Secondary = 2.41 cfs @ 12.13 hrs, Volume= 2,996 cf
 Routed to Reach DP-1 : French Rodney Blvd Outfall

Routing by Stor-Ind method, Time Span= 0.00-72.00 hrs, dt= 0.05 hrs
 Peak Elev= 10.10' @ 12.13 hrs

Device	Routing	Invert	Outlet Devices
#1	Primary	9.00'	6.0" Vert. WATER QUALITY STORM DIVERSION C= 0.600 Limited to weir flow at low heads
#2	Secondary	9.20'	12.0" Vert. LARGE STORM OVEFLOW C= 0.600 Limited to weir flow at low heads

Primary OutFlow Max=0.86 cfs @ 12.13 hrs HW=10.07' (Free Discharge)
 ↳1=WATER QUALITY STORM DIVERSION(Orifice Controls 0.86 cfs @ 4.35 fps)

Secondary OutFlow Max=2.30 cfs @ 12.13 hrs HW=10.07' (Free Discharge)
 ↳2=LARGE STORM OVEFLOW (Orifice Controls 2.30 cfs @ 3.17 fps)

14850_Proposed-Drainage-Areas_220609

NOAA 24-hr C NOAA 100-yr Rainfall=7.59"

Prepared by {enter your company name here}

Printed 6/16/2022

HydroCAD® 10.10-7a s/n 00546 © 2021 HydroCAD Software Solutions LLC

Page 75

Summary for Pond DMH2: DIVERSION MANHOLE - HUDSON STREET

[57] Hint: Peaked at 35.73' (Flood elevation advised)

Inflow Area = 143,309 sf, 49.69% Impervious, Inflow Depth = 5.93" for NOAA 100-yr event
 Inflow = 23.44 cfs @ 12.13 hrs, Volume= 70,873 cf
 Outflow = 23.44 cfs @ 12.13 hrs, Volume= 70,873 cf, Atten= 0%, Lag= 0.0 min
 Primary = 4.74 cfs @ 12.13 hrs, Volume= 35,221 cf
 Routed to Pond INF-2 : INFILTRATION SYSTEM #2
 Secondary = 18.70 cfs @ 12.13 hrs, Volume= 35,651 cf
 Routed to Reach B : PARKING LOT B OVERFLOW

Routing by Stor-Ind method, Time Span= 0.00-72.00 hrs, dt= 0.05 hrs

Peak Elev= 35.73' @ 12.13 hrs

Device	Routing	Invert	Outlet Devices
#1	Primary	10.60'	6.0" Vert. WATER QUALITY STORM DIVERSION C= 0.600 Limited to weir flow at low heads
#2	Secondary	11.10'	12.0" Vert. LARGE STORM OVERFLOW C= 0.600 Limited to weir flow at low heads

Primary OutFlow Max=4.56 cfs @ 12.13 hrs HW=34.10' (Free Discharge)

↳1=WATER QUALITY STORM DIVERSION(Orifice Controls 4.56 cfs @ 23.22 fps)

Secondary OutFlow Max=17.94 cfs @ 12.13 hrs HW=34.10' (Free Discharge)

↳2=LARGE STORM OVERFLOW(Orifice Controls 17.94 cfs @ 22.84 fps)

14850_Proposed-Drainage-Areas_220609

NOAA 24-hr C NOAA 100-yr Rainfall=7.59"

Prepared by {enter your company name here}

Printed 6/16/2022

HydroCAD® 10.10-7a s/n 00546 © 2021 HydroCAD Software Solutions LLC

Page 76

Summary for Pond DMH3: DIVERSION MANHOLE - PORTLAND ST

[57] Hint: Peaked at 12.07' (Flood elevation advised)

Inflow Area = 19,743 sf, 50.83% Impervious, Inflow Depth = 5.93" for NOAA 100-yr event
 Inflow = 3.23 cfs @ 12.13 hrs, Volume= 9,764 cf
 Outflow = 3.23 cfs @ 12.13 hrs, Volume= 9,764 cf, Atten= 0%, Lag= 0.0 min
 Primary = 1.44 cfs @ 12.13 hrs, Volume= 7,738 cf
 Routed to Pond INF3 : INFILTRATION SYSTEM #1
 Secondary = 1.78 cfs @ 12.13 hrs, Volume= 2,026 cf
 Routed to Reach P ST : PORTLAND STREET DRAINAGE

Routing by Stor-Ind method, Time Span= 0.00-72.00 hrs, dt= 0.05 hrs

Peak Elev= 12.07' @ 12.13 hrs

Device	Routing	Invert	Outlet Devices
#1	Primary	11.00'	8.0" Vert. WATER QUALITY DIVERSION C= 0.600 Limited to weir flow at low heads
#2	Secondary	11.20'	10.0" Vert. LARGE STORM OVERFLOW C= 0.600 Limited to weir flow at low heads

Primary OutFlow Max=1.40 cfs @ 12.13 hrs HW=12.03' (Free Discharge)

↳1=WATER QUALITY DIVERSION(Orifice Controls 1.40 cfs @ 4.02 fps)

Secondary OutFlow Max=1.69 cfs @ 12.13 hrs HW=12.03' (Free Discharge)

↳2=LARGE STORM OVERFLOW(Orifice Controls 1.69 cfs @ 3.10 fps)

Summary for Pond INF-1: INFILTRATION SYSTEM #1

[88] Warning: Qout>Qin may require smaller dt or Finer Routing
 [81] Warning: Exceeded Pond DMH1 by 0.24' @ 16.80 hrs

Inflow Area = 19,582 sf, 58.17% Impervious, Inflow Depth = 4.33" for NOAA 100-yr event
 Inflow = 0.87 cfs @ 12.13 hrs, Volume= 7,068 cf
 Outflow = 0.89 cfs @ 12.17 hrs, Volume= 7,068 cf, Atten= 0%, Lag= 2.5 min
 Discarded = 0.08 cfs @ 12.17 hrs, Volume= 5,184 cf
 Primary = 0.82 cfs @ 12.17 hrs, Volume= 1,885 cf
 Routed to Reach DP-1 : French Rodney Blvd Outfall

Routing by Stor-Ind method, Time Span= 0.00-72.00 hrs, dt= 0.05 hrs
 Peak Elev= 9.53' @ 12.17 hrs Surf.Area= 1,772 sf Storage= 1,727 cf

Plug-Flow detention time= 185.9 min calculated for 7,068 cf (100% of inflow)
 Center-of-Mass det. time= 185.8 min (996.2 - 810.4)

Volume	Invert	Avail.Storage	Storage Description
#1A	7.80'	1,091 cf	21.50'W x 81.52'L x 2.33'H Field A 4,090 cf Overall - 973 cf Embedded = 3,117 cf x 35.0% Voids
#2A	8.30'	973 cf	ADS_StormTech SC-310 +Cap x 66 Inside #1 Effective Size= 28.9"W x 16.0"H => 2.07 sf x 7.12'L = 14.7 cf Overall Size= 34.0"W x 16.0"H x 7.56'L with 0.44' Overlap 66 Chambers in 6 Rows
#3	7.80'	137 cf	5.00'D x 7.00'H Vertical Cone/Cylinder
		2,201 cf	Total Available Storage

Storage Group A created with Chamber Wizard

Device	Routing	Invert	Outlet Devices
#1	Discarded	7.80'	1.020 in/hr Exfiltration over Surface area Conductivity to Groundwater Elevation = 5.80'
#2	Primary	8.10'	10.0" Round Culvert L= 10.0' CPP, square edge headwall, Ke= 0.500 Inlet / Outlet Invert= 8.10' / 8.00' S= 0.0100 '/' Cc= 0.900 n= 0.012 Corrugated PP, smooth interior, Flow Area= 0.55 sf
#3	Device 2	9.40'	5.0' long Sharp-Crested Rectangular Weir 2 End Contraction(s)

Discarded OutFlow Max=0.08 cfs @ 12.17 hrs HW=9.53' (Free Discharge)
 ↳ **1=Exfiltration** (Controls 0.08 cfs)

Primary OutFlow Max=0.74 cfs @ 12.17 hrs HW=9.53' (Free Discharge)
 ↳ **2=Culvert** (Passes 0.74 cfs of 2.64 cfs potential flow)
 ↳ **3=Sharp-Crested Rectangular Weir**(Weir Controls 0.74 cfs @ 1.17 fps)

Pond INF-1: INFILTRATION SYSTEM #1 - Chamber Wizard Field A

Chamber Model = ADS_StormTechSC-310 +Cap (ADS StormTech®SC-310 with cap length)
 Effective Size= 28.9"W x 16.0"H => 2.07 sf x 7.12'L = 14.7 cf
 Overall Size= 34.0"W x 16.0"H x 7.56'L with 0.44' Overlap

34.0" Wide + 6.0" Spacing = 40.0" C-C Row Spacing

11 Chambers/Row x 7.12' Long +0.60' Cap Length x 2 = 79.52' Row Length +12.0" End Stone x 2 = 81.52' Base Length
 6 Rows x 34.0" Wide + 6.0" Spacing x 5 + 12.0" Side Stone x 2 = 21.50' Base Width
 6.0" Stone Base + 16.0" Chamber Height + 6.0" Stone Cover = 2.33' Field Height

66 Chambers x 14.7 cf = 973.0 cf Chamber Storage

4,089.6 cf Field - 973.0 cf Chambers = 3,116.6 cf Stone x 35.0% Voids = 1,090.8 cf Stone Storage

Chamber Storage + Stone Storage = 2,063.8 cf = 0.047 af
 Overall Storage Efficiency = 50.5%
 Overall System Size = 81.52' x 21.50' x 2.33'

66 Chambers
 151.5 cy Field
 115.4 cy Stone

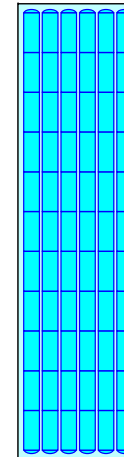

Summary for Pond INF-2: INFILTRATION SYSTEM #2

Inflow Area = 143,309 sf, 49.69% Impervious, Inflow Depth = 2.95" for NOAA 100-yr event
 Inflow = 4.74 cfs @ 12.13 hrs, Volume= 35,221 cf
 Outflow = 3.57 cfs @ 12.19 hrs, Volume= 35,221 cf, Atten= 25%, Lag= 3.8 min
 Discarded = 0.12 cfs @ 12.19 hrs, Volume= 10,022 cf
 Primary = 3.44 cfs @ 12.19 hrs, Volume= 25,199 cf
 Routed to Reach B : PARKING LOT B OVERFLOW

Routing by Stor-Ind method, Time Span= 0.00-72.00 hrs, dt= 0.05 hrs
 Peak Elev= 10.13' @ 12.19 hrs Surf.Area= 2,268 sf Storage= 3,861 cf

Plug-Flow detention time= 107.8 min calculated for 35,221 cf (100% of inflow)
 Center-of-Mass det. time= 107.7 min (957.5 - 849.8)

Volume	Invert	Avail.Storage	Storage Description
#1A	7.50'	1,790 cf	25.25'W x 89.06'L x 3.50'H Field A 7,870 cf Overall - 2,756 cf Embedded = 5,114 cf x 35.0% Voids
#2A	8.00'	2,756 cf	ADS_StormTech SC-740 +Cap x 60 Inside #1 Effective Size= 44.6"W x 30.0"H => 6.45 sf x 7.12'L = 45.9 cf Overall Size= 51.0"W x 30.0"H x 7.56'L with 0.44' Overlap 60 Chambers in 5 Rows
#3	7.50'	137 cf	5.00'D x 7.00'H Vertical Cone/Cylinder
		4,684 cf	Total Available Storage

Storage Group A created with Chamber Wizard

Device	Routing	Invert	Outlet Devices
#1	Discarded	7.50'	1.020 in/hr Exfiltration over Surface area Conductivity to Groundwater Elevation = 5.50'
#2	Primary	8.00'	10.0" Round Culvert L= 10.0' CPP, square edge headwall, Ke= 0.500 Inlet / Outlet Invert= 8.00' / 7.90' S= 0.0100 '/ Cc= 0.900 n= 0.012 Corrugated PP, smooth interior, Flow Area= 0.55 sf
#3	Device 2	9.50'	5.0' long Sharp-Crested Rectangular Weir 2 End Contraction(s)

Discarded OutFlow Max=0.12 cfs @ 12.19 hrs HW=10.12' (Free Discharge)
 1=Exfiltration (Controls 0.12 cfs)

Primary OutFlow Max=3.43 cfs @ 12.19 hrs HW=10.12' (Free Discharge)
 2=Culvert (Inlet Controls 3.43 cfs @ 6.29 fps)
 3=Sharp-Crested Rectangular Weir(Passes 3.43 cfs of 7.81 cfs potential flow)

Pond INF-2: INFILTRATION SYSTEM #2 - Chamber Wizard Field A

Chamber Model = ADS_StormTechSC-740 +Cap (ADS StormTech®SC-740 with cap length)
 Effective Size= 44.6"W x 30.0"H => 6.45 sf x 7.12'L = 45.9 cf
 Overall Size= 51.0"W x 30.0"H x 7.56'L with 0.44' Overlap

51.0" Wide + 6.0" Spacing = 57.0" C-C Row Spacing

12 Chambers/Row x 7.12' Long +0.81' Cap Length x 2 = 87.06' Row Length +12.0" End Stone x 2 = 89.06'
 Base Length
 5 Rows x 51.0" Wide + 6.0" Spacing x 4 + 12.0" Side Stone x 2 = 25.25' Base Width
 6.0" Stone Base + 30.0" Chamber Height + 6.0" Stone Cover = 3.50' Field Height

60 Chambers x 45.9 cf = 2,756.4 cf Chamber Storage

7,870.4 cf Field - 2,756.4 cf Chambers = 5,114.0 cf Stone x 35.0% Voids = 1,789.9 cf Stone Storage

Chamber Storage + Stone Storage = 4,546.3 cf = 0.104 af
 Overall Storage Efficiency = 57.8%
 Overall System Size = 89.06' x 25.25' x 3.50'

60 Chambers
 291.5 cy Field
 189.4 cy Stone

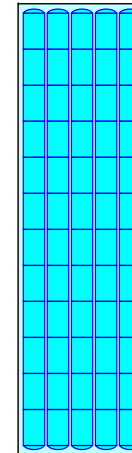

Summary for Pond INF3: INFILTRATION SYSTEM #1

Inflow Area = 19,743 sf, 50.83% Impervious, Inflow Depth = 4.70" for NOAA 100-yr event
 Inflow = 1.44 cfs @ 12.13 hrs, Volume= 7,738 cf
 Outflow = 1.43 cfs @ 12.14 hrs, Volume= 7,738 cf, Atten= 1%, Lag= 0.9 min
 Discarded = 0.05 cfs @ 12.14 hrs, Volume= 3,496 cf
 Primary = 1.39 cfs @ 12.14 hrs, Volume= 4,242 cf
 Routed to Reach P ST : PORTLAND STREET DRAINAGE

Routing by Stor-Ind method, Time Span= 0.00-72.00 hrs, dt= 0.05 hrs
 Peak Elev= 9.69' @ 12.14 hrs Surf.Area= 1,113 sf Storage= 1,012 cf

Plug-Flow detention time= 116.2 min calculated for 7,732 cf (100% of inflow)
 Center-of-Mass det. time= 116.4 min (925.1 - 808.6)

Volume	Invert	Avail.Storage	Storage Description
#1A	8.10'	686 cf	18.17'W x 60.16'L x 2.33'H Field A 2,550 cf Overall - 590 cf Embedded = 1,960 cf x 35.0% Voids
#2A	8.60'	590 cf	ADS_StormTech SC-310 +Cap x 40 Inside #1 Effective Size= 28.9"W x 16.0"H => 2.07 sf x 7.12'L = 14.7 cf Overall Size= 34.0"W x 16.0"H x 7.56'L with 0.44' Overlap 40 Chambers in 5 Rows
#3	8.10'	137 cf	5.00'D x 7.00'H Vertical Cone/Cylinder
		1,413 cf	Total Available Storage

Storage Group A created with Chamber Wizard

Device	Routing	Invert	Outlet Devices
#1	Discarded	8.10'	1.020 in/hr Exfiltration over Surface area Conductivity to Groundwater Elevation = 6.10'
#2	Primary	8.40'	10.0" Round Culvert L= 10.0' CPP, square edge headwall, Ke= 0.500 Inlet / Outlet Invert= 8.40' / 8.30' S= 0.0100 '/ Cc= 0.900 n= 0.012 Corrugated PP, smooth interior, Flow Area= 0.55 sf
#3	Device 2	9.50'	5.0' long Sharp-Crested Rectangular Weir 2 End Contraction(s)

Discarded OutFlow Max=0.05 cfs @ 12.14 hrs HW=9.69' (Free Discharge)
 ↳1=Exfiltration (Controls 0.05 cfs)

Primary OutFlow Max=1.36 cfs @ 12.14 hrs HW=9.69' (Free Discharge)
 ↳2=Culvert (Passes 1.36 cfs of 2.41 cfs potential flow)
 ↳3=Sharp-Crested Rectangular Weir(Weir Controls 1.36 cfs @ 1.43 fps)

Pond INF3: INFILTRATION SYSTEM #1 - Chamber Wizard Field A

Chamber Model = ADS_StormTechSC-310 +Cap (ADS StormTech®SC-310 with cap length)
 Effective Size= 28.9"W x 16.0"H => 2.07 sf x 7.12'L = 14.7 cf
 Overall Size= 34.0"W x 16.0"H x 7.56'L with 0.44' Overlap

34.0" Wide + 6.0" Spacing = 40.0" C-C Row Spacing

8 Chambers/Row x 7.12' Long +0.60' Cap Length x 2 = 58.16' Row Length +12.0" End Stone x 2 = 60.16' Base Length
 5 Rows x 34.0" Wide + 6.0" Spacing x 4 + 12.0" Side Stone x 2 = 18.17' Base Width
 6.0" Stone Base + 16.0" Chamber Height + 6.0" Stone Cover = 2.33' Field Height

40 Chambers x 14.7 cf = 589.7 cf Chamber Storage

2,550.1 cf Field - 589.7 cf Chambers = 1,960.4 cf Stone x 35.0% Voids = 686.2 cf Stone Storage

Chamber Storage + Stone Storage = 1,275.8 cf = 0.029 af
 Overall Storage Efficiency = 50.0%
 Overall System Size = 60.16' x 18.17' x 2.33'

40 Chambers
 94.4 cy Field
 72.6 cy Stone

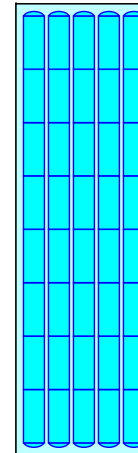

14850_Proposed-Drainage-Areas_220609

NOAA 24-hr C NOAA 2-yr Rainfall=3.40"

Prepared by {enter your company name here}

Printed 6/16/2022

HydroCAD® 10.10-7a s/n 00546 © 2021 HydroCAD Software Solutions LLC

Page 83

Time span=0.00-72.00 hrs, dt=0.05 hrs, 1441 points
 Runoff by SCS TR-20 method, UH=SCS, Weighted-CN
 Reach routing by Stor-Ind+Trans method - Pond routing by Stor-Ind method

Pond 1-P: BB 1 Peak Elev=10.08' Storage=900 cf Inflow=2.27 cfs 6,504 cf
 Discarded=0.05 cfs 2,289 cf Primary=0.66 cfs 362 cf Secondary=1.47 cfs 3,853 cf Outflow=2.18 cfs 6,504 cf

Pond 2a-P: BB 2a Peak Elev=9.33' Storage=242 cf Inflow=0.24 cfs 765 cf
 Primary=0.10 cfs 76 cf Secondary=0.03 cfs 689 cf Outflow=0.13 cfs 765 cf

Pond 2b-P: BB 2b Peak Elev=8.25' Storage=106 cf Inflow=1.57 cfs 4,725 cf
 Primary=1.54 cfs 4,725 cf Secondary=0.00 cfs 0 cf Outflow=1.54 cfs 4,725 cf

Pond 3A-P: BB 3A Peak Elev=11.02' Storage=405 cf Inflow=0.69 cfs 1,994 cf
 Discarded=0.02 cfs 1,062 cf Primary=0.63 cfs 932 cf Outflow=0.65 cfs 1,994 cf

Pond 3B-P: BB 3B Peak Elev=12.87' Storage=244 cf Inflow=0.33 cfs 999 cf
 Discarded=0.01 cfs 642 cf Primary=0.31 cfs 358 cf Outflow=0.33 cfs 999 cf

Pond 4A-P: BB 4A - POND Peak Elev=10.02' Storage=212 cf Inflow=0.37 cfs 1,147 cf
 Primary=0.32 cfs 307 cf Secondary=0.03 cfs 839 cf Outflow=0.35 cfs 1,147 cf

Pond 4A-S: BB4A-Stone Peak Elev=7.12' Storage=26 cf Inflow=0.03 cfs 839 cf
 Outflow=0.03 cfs 822 cf

Pond 4B-P: BB 4B - POND Peak Elev=11.00' Storage=124 cf Inflow=0.23 cfs 722 cf
 Primary=0.21 cfs 199 cf Secondary=0.02 cfs 522 cf Outflow=0.23 cfs 722 cf

Pond 4B-S: BB 4A-Stone Peak Elev=7.84' Storage=15 cf Inflow=0.02 cfs 522 cf
 Outflow=0.02 cfs 512 cf

Pond 5A-P: BB 5A - POND Peak Elev=9.16' Storage=195 cf Inflow=0.22 cfs 651 cf
 Primary=0.00 cfs 0 cf Secondary=0.04 cfs 651 cf Outflow=0.04 cfs 651 cf

Pond 5A-PS: BB 5A-Stone Peak Elev=5.93' Storage=54 cf Inflow=0.04 cfs 651 cf
 Outflow=0.04 cfs 615 cf

Pond 5B-P: BB 5B - POND Peak Elev=8.97' Storage=667 cf Inflow=2.40 cfs 7,086 cf
 Primary=0.57 cfs 267 cf Secondary=0.09 cfs 3,100 cf Tertiary=1.68 cfs 3,719 cf Outflow=2.35 cfs 7,086 cf

Pond 5B-PS: BB 5B-Stone Peak Elev=5.45' Storage=94 cf Inflow=0.09 cfs 3,100 cf
 Outflow=0.09 cfs 3,048 cf

Pond 6A-P: BB 6A - POND Peak Elev=10.94' Storage=378 cf Inflow=0.85 cfs 2,436 cf
 Primary=0.77 cfs 996 cf Secondary=0.04 cfs 1,440 cf Outflow=0.82 cfs 2,436 cf

Pond 6A-PS: BB 6A - STONE Peak Elev=7.39' Storage=34 cf Inflow=0.04 cfs 1,440 cf
 Outflow=0.04 cfs 1,418 cf

Pond 6B-P: BB 6B Peak Elev=12.04' Storage=356 cf Inflow=0.47 cfs 1,428 cf
 Discarded=0.02 cfs 871 cf Primary=0.43 cfs 557 cf Outflow=0.44 cfs 1,428 cf

14850_Proposed-Drainage-Areas_220609

NOAA 24-hr C NOAA 2-yr Rainfall=3.40"

Prepared by {enter your company name here}

Printed 6/16/2022

HydroCAD® 10.10-7a s/n 00546 © 2021 HydroCAD Software Solutions LLC

Page 84

Pond 7A-P: BB 7A PONDING Peak Elev=9.96' Storage=141 cf Inflow=0.24 cfs 749 cf
 Primary=0.22 cfs 210 cf Secondary=0.02 cfs 539 cf Outflow=0.24 cfs 749 cf

Pond 7A-S: BB 7A - STONE Peak Elev=5.19' Storage=4 cf Inflow=0.02 cfs 539 cf
 Outflow=0.02 cfs 539 cf

Pond 7B-P: BB 7B PONDING Peak Elev=10.68' Storage=258 cf Inflow=0.38 cfs 1,170 cf
 Primary=0.33 cfs 283 cf Secondary=0.03 cfs 887 cf Outflow=0.37 cfs 1,170 cf

Pond 7B-S: BB 7B - STONE Peak Elev=7.62' Storage=17 cf Inflow=0.03 cfs 887 cf
 Outflow=0.03 cfs 875 cf

Pond 8a-P: BB 8A PONDING Peak Elev=9.03' Storage=250 cf Inflow=0.29 cfs 875 cf
 Primary=0.10 cfs 79 cf Secondary=0.04 cfs 795 cf Outflow=0.14 cfs 875 cf

Pond 8a-S: BB 8A - STONE Peak Elev=5.63' Storage=29 cf Inflow=0.04 cfs 795 cf
 Outflow=0.04 cfs 777 cf

Pond 8B-P: BB 8B-PONDING Peak Elev=9.70' Storage=242 cf Inflow=0.43 cfs 1,325 cf
 Primary=0.38 cfs 364 cf Secondary=0.04 cfs 962 cf Outflow=0.41 cfs 1,325 cf

Pond 8B-S: BB 8B-Stone Peak Elev=6.33' Storage=39 cf Inflow=0.04 cfs 962 cf
 Outflow=0.04 cfs 935 cf

Pond 9-P: BB9 - POND Peak Elev=8.80' Storage=343 cf Inflow=2.10 cfs 6,279 cf
 Primary=0.01 cfs 2 cf Secondary=0.04 cfs 1,929 cf Tertiary=2.00 cfs 4,348 cf Outflow=2.05 cfs 6,279 cf

Pond 9-PS: BB9 - STONE Peak Elev=5.39' Storage=22 cf Inflow=0.04 cfs 1,929 cf
 Outflow=0.04 cfs 1,915 cf

Pond 14P: BB2A-Stone Peak Elev=5.60' Storage=6 cf Inflow=0.03 cfs 689 cf
 Outflow=0.03 cfs 689 cf

Pond DMH1: DIVERSION MANHOLE - SEYMOUR ST Peak Elev=9.61' Inflow=1.23 cfs 3,554 cf
 Primary=0.57 cfs 2,974 cf Secondary=0.66 cfs 580 cf Outflow=1.23 cfs 3,554 cf

Pond DMH2: DIVERSION MANHOLE - HUDSON STREET Peak Elev=14.56' Inflow=8.38 cfs 24,005 cf
 Primary=1.83 cfs 15,418 cf Secondary=6.55 cfs 8,588 cf Outflow=8.38 cfs 24,005 cf

Pond DMH3: DIVERSION MANHOLE - PORTLANDST Peak Elev=11.54' Inflow=1.15 cfs 3,307 cf
 Primary=0.75 cfs 2,972 cf Secondary=0.40 cfs 335 cf Outflow=1.15 cfs 3,307 cf

Pond INF-1: INFILTRATIONSYSTEM#1 Peak Elev=9.01' Storage=1,232 cf Inflow=0.57 cfs 2,974 cf
 Discarded=0.07 cfs 2,974 cf Primary=0.00 cfs 0 cf Outflow=0.07 cfs 2,974 cf

Pond INF-2: INFILTRATIONSYSTEM#2 Peak Elev=9.70' Storage=3,280 cf Inflow=1.83 cfs 15,418 cf
 Discarded=0.11 cfs 8,554 cf Primary=1.42 cfs 6,864 cf Outflow=1.53 cfs 15,418 cf

Pond INF3: INFILTRATIONSYSTEM#1 Peak Elev=9.57' Storage=944 cf Inflow=0.75 cfs 2,972 cf
 Discarded=0.05 cfs 2,339 cf Primary=0.33 cfs 633 cf Outflow=0.38 cfs 2,972 cf

14850_Proposed-Drainage-Areas_220609

NOAA 24-hr C NOAA 2-yr Rainfall=3.40"

Prepared by {enter your company name here}

Printed 6/16/2022

HydroCAD® 10.10-7a s/n 00546 © 2021 HydroCAD Software Solutions LLC

Page 85

Summary for Pond 1-P: BB 1

Inflow Area = 38,826 sf, 51.66% Impervious, Inflow Depth = 2.01" for NOAA 2-yr event
 Inflow = 2.27 cfs @ 12.13 hrs, Volume= 6,504 cf
 Outflow = 2.18 cfs @ 12.15 hrs, Volume= 6,504 cf, Atten= 4%, Lag= 1.3 min
 Discarded = 0.05 cfs @ 12.15 hrs, Volume= 2,289 cf
 Primary = 0.66 cfs @ 12.15 hrs, Volume= 362 cf
 Routed to Reach 17R : Rodney French Pipe
 Secondary = 1.47 cfs @ 12.15 hrs, Volume= 3,853 cf
 Routed to Reach 15R : ISOLATOR ROW 1

Routing by Stor-Ind method, Time Span= 0.00-72.00 hrs, dt= 0.05 hrs
 Peak Elev= 10.08' @ 12.15 hrs Surf.Area= 1,649 sf Storage= 900 cf

Plug-Flow detention time= 81.1 min calculated for 6,499 cf (100% of inflow)
 Center-of-Mass det. time= 81.4 min (904.5 - 823.1)

Volume	Invert	Avail.Storage	Storage Description
#1	9.20'	1,114 cf	Custom Stage Data (Prismatic) Listed below (Recalc)

Elevation (feet)	Surf.Area (sq-ft)	Inc.Store (cubic-feet)	Cum.Store (cubic-feet)
9.20	490	0	0
9.50	800	194	194
10.20	1,830	920	1,114

Device	Routing	Invert	Outlet Devices
#1	Primary	8.00'	12.0" Round Culvert L= 10.0' CPP, square edge headwall, Ke= 0.500 Inlet / Outlet Invert= 8.00' / 7.90' S= 0.0100 '/ Cc= 0.900 n= 0.013, Flow Area= 0.79 sf
#2	Discarded	9.20'	1.020 in/hr Exfiltration over Surface area Conductivity to Groundwater Elevation = 6.00'
#3	Device 1	10.00'	24inch-Dome Grate Capacity X 2.00
#4	Secondary	9.83'	15inch-Dome Grate Capacity

Discarded OutFlow Max=0.05 cfs @ 12.15 hrs HW=10.08' (Free Discharge)
 ↳2=Exfiltration (Controls 0.05 cfs)

Primary OutFlow Max=0.65 cfs @ 12.15 hrs HW=10.08' (Free Discharge)
 ↳1=Culvert (Passes 0.65 cfs of 4.75 cfs potential flow)
 ↳3=24inch-Dome Grate Capacity (Custom Controls 0.65 cfs)

Secondary OutFlow Max=1.47 cfs @ 12.15 hrs HW=10.08' (Free Discharge)
 ↳4=15inch-Dome Grate Capacity (Custom Controls 1.47 cfs)

14850_Proposed-Drainage-Areas_220609

NOAA 24-hr C NOAA 2-yr Rainfall=3.40"

Prepared by {enter your company name here}

Printed 6/16/2022

HydroCAD® 10.10-7a s/n 00546 © 2021 HydroCAD Software Solutions LLC

Page 86

Summary for Pond 2a-P: BB 2a

Inflow Area = 3,116 sf, 92.62% Impervious, Inflow Depth = 2.95" for NOAA 2-yr event
 Inflow = 0.24 cfs @ 12.13 hrs, Volume= 765 cf
 Outflow = 0.13 cfs @ 12.26 hrs, Volume= 765 cf, Atten= 47%, Lag= 8.2 min
 Primary = 0.10 cfs @ 12.26 hrs, Volume= 76 cf
 Routed to Reach DP-1 : French Rodney Blvd Outfall
 Secondary = 0.03 cfs @ 12.26 hrs, Volume= 689 cf
 Routed to Pond 14P : BB2A-Stone

Routing by Stor-Ind method, Time Span= 0.00-72.00 hrs, dt= 0.05 hrs
 Peak Elev= 9.33' @ 12.26 hrs Surf.Area= 403 sf Storage= 242 cf

Plug-Flow detention time= 72.5 min calculated for 765 cf (100% of inflow)
 Center-of-Mass det. time= 72.5 min (846.6 - 774.1)

Volume	Invert	Avail.Storage	Storage Description
#1	8.50'	462 cf	Custom Stage Data (Prismatic) Listed below (Recalc)

Elevation (feet)	Surf.Area (sq-ft)	Inc.Store (cubic-feet)	Cum.Store (cubic-feet)
8.50	180	0	0
9.80	530	462	462

Device	Routing	Invert	Outlet Devices
#1	Primary	7.80'	10.0" Round Culvert L= 10.0' CPP, square edge headwall, Ke= 0.500 Inlet / Outlet Invert= 7.80' / 7.70' S= 0.0100 '/ Cc= 0.900 n= 0.013, Flow Area= 0.55 sf
#2	Device 1	9.30'	24inch-Dome Grate Capacity
#3	Secondary	8.50'	2.410 in/hr Exfiltration over Surface area Conductivity to Groundwater Elevation = 4.60'

Primary OutFlow Max=0.09 cfs @ 12.26 hrs HW=9.33' (Free Discharge)
 ↳1=Culvert (Passes 0.09 cfs of 2.77 cfs potential flow)
 ↳2=24inch-Dome Grate Capacity (Custom Controls 0.09 cfs)

Secondary OutFlow Max=0.03 cfs @ 12.26 hrs HW=9.33' (Free Discharge)
 ↳3=Exfiltration (Controls 0.03 cfs)

14850_Proposed-Drainage-Areas_220609

NOAA 24-hr C NOAA 2-yr Rainfall=3.40"

Prepared by {enter your company name here}

Printed 6/16/2022

HydroCAD® 10.10-7a s/n 00546 © 2021 HydroCAD Software Solutions LLC

Page 87

Summary for Pond 2b-P: BB 2b

Inflow Area = 21,490 sf, 80.50% Impervious, Inflow Depth = 2.64" for NOAA 2-yr event
 Inflow = 1.57 cfs @ 12.13 hrs, Volume= 4,725 cf
 Outflow = 1.54 cfs @ 12.14 hrs, Volume= 4,725 cf, Atten= 2%, Lag= 1.0 min
 Primary = 1.54 cfs @ 12.14 hrs, Volume= 4,725 cf
 Routed to Reach 15R : ISOLATOR ROW 1
 Secondary = 0.00 cfs @ 0.00 hrs, Volume= 0 cf
 Routed to Reach DP-1 : French Rodney Blvd Outfall

Routing by Stor-Ind method, Time Span= 0.00-72.00 hrs, dt= 0.05 hrs
 Peak Elev= 8.25' @ 12.14 hrs Surf.Area= 518 sf Storage= 106 cf

Plug-Flow detention time= 1.8 min calculated for 4,722 cf (100% of inflow)
 Center-of-Mass det. time= 1.8 min (794.9 - 793.1)

Volume	Invert	Avail.Storage	Storage Description
#1	8.00'	710 cf	Custom Stage Data (Prismatic) Listed below (Recalc)
Elevation (feet)	Surf.Area (sq-ft)	Inc.Store (cubic-feet)	Cum.Store (cubic-feet)
8.00	320	0	0
9.00	1,100	710	710

Device	Routing	Invert	Outlet Devices
#1	Secondary	7.00'	12.0" Round Culvert L= 10.0' CPP, square edge headwall, Ke= 0.500 Inlet / Outlet Invert= 7.00' / 6.90' S= 0.0100 '/ Cc= 0.900 n= 0.013, Flow Area= 0.79 sf
#2	Device 1	8.50'	24inch-Dome Grate Capacity X 2.00
#3	Primary	8.00'	15inch-Dome Grate Capacity

Primary OutFlow Max=1.51 cfs @ 12.14 hrs HW=8.25' (Free Discharge)
 ↳3=15inch-Dome Grate Capacity (Custom Controls 1.51 cfs)

Secondary OutFlow Max=0.00 cfs @ 0.00 hrs HW=8.00' (Free Discharge)
 ↳1=Culvert (Passes 0.00 cfs of 2.27 cfs potential flow)
 ↳2=24inch-Dome Grate Capacity (Controls 0.00 cfs)

14850_Proposed-Drainage-Areas_220609

NOAA 24-hr C NOAA 2-yr Rainfall=3.40"

Prepared by {enter your company name here}

Printed 6/16/2022

HydroCAD® 10.10-7a s/n 00546 © 2021 HydroCAD Software Solutions LLC

Page 88

Summary for Pond 3A-P: BB 3A

Inflow Area = 10,987 sf, 58.16% Impervious, Inflow Depth = 2.18" for NOAA 2-yr event
 Inflow = 0.69 cfs @ 12.13 hrs, Volume= 1,994 cf
 Outflow = 0.65 cfs @ 12.16 hrs, Volume= 1,994 cf, Atten= 6%, Lag= 1.6 min
 Discarded = 0.02 cfs @ 12.16 hrs, Volume= 1,062 cf
 Primary = 0.63 cfs @ 12.16 hrs, Volume= 932 cf
 Routed to Reach BMP_3 : BMP-3_OVERFLOW

Routing by Stor-Ind method, Time Span= 0.00-72.00 hrs, dt= 0.05 hrs
 Peak Elev= 11.02' @ 12.16 hrs Surf.Area= 850 sf Storage= 405 cf

Plug-Flow detention time= 110.1 min calculated for 1,992 cf (100% of inflow)
 Center-of-Mass det. time= 110.2 min (925.8 - 815.6)

Volume	Invert	Avail.Storage	Storage Description
#1	10.25'	622 cf	Custom Stage Data (Prismatic) Listed below (Recalc)
Elevation (feet)	Surf.Area (sq-ft)	Inc.Store (cubic-feet)	Cum.Store (cubic-feet)
10.25	271	0	0
10.45	350	62	62
11.25	1,050	560	622

Device	Routing	Invert	Outlet Devices
#1	Primary	9.30'	10.0" Round Culvert L= 10.0' CPP, square edge headwall, Ke= 0.500 Inlet / Outlet Invert= 9.30' / 9.20' S= 0.0100 '/ Cc= 0.900 n= 0.013, Flow Area= 0.55 sf
#2	Discarded	10.25'	1.020 in/hr Exfiltration over Surface area Conductivity to Groundwater Elevation = 7.30'
#3	Primary	11.15'	5.0' long Sharp-Crested Rectangular Weir 2 End Contraction(s)
#4	Device 1	10.90'	24inch-Dome Grate Capacity

Discarded OutFlow Max=0.02 cfs @ 12.16 hrs HW=11.02' (Free Discharge)
 ↳2=Exfiltration (Controls 0.02 cfs)

Primary OutFlow Max=0.61 cfs @ 12.16 hrs HW=11.02' (Free Discharge)
 ↳1=Culvert (Passes 0.61 cfs of 3.00 cfs potential flow)
 ↳4=24inch-Dome Grate Capacity (Custom Controls 0.61 cfs)
 ↳3=Sharp-Crested Rectangular Weir (Controls 0.00 cfs)

14850_Proposed-Drainage-Areas_220609

NOAA 24-hr C NOAA 2-yr Rainfall=3.40"

Prepared by {enter your company name here}

Printed 6/16/2022

HydroCAD® 10.10-7a s/n 00546 © 2021 HydroCAD Software Solutions LLC

Page 89

Summary for Pond 3B-P: BB 3B

Inflow Area = 4,545 sf, 77.34% Impervious, Inflow Depth = 2.64" for NOAA 2-yr event
 Inflow = 0.33 cfs @ 12.13 hrs, Volume= 999 cf
 Outflow = 0.33 cfs @ 12.15 hrs, Volume= 999 cf, Atten= 1%, Lag= 1.4 min
 Discarded = 0.01 cfs @ 12.15 hrs, Volume= 642 cf
 Primary = 0.31 cfs @ 12.15 hrs, Volume= 358 cf
 Routed to Reach BMP_3 : BMP-3_OVERFLOW

Routing by Stor-Ind method, Time Span= 0.00-72.00 hrs, dt= 0.05 hrs
 Peak Elev= 12.87' @ 12.15 hrs Surf.Area= 552 sf Storage= 244 cf

Plug-Flow detention time= 116.0 min calculated for 999 cf (100% of inflow)
 Center-of-Mass det. time= 116.0 min (909.1 - 793.1)

Volume	Invert	Avail.Storage	Storage Description
#1	12.20'	263 cf	Custom Stage Data (Prismatic) Listed below (Recalc)
Elevation (feet)	Surf.Area (sq-ft)	Inc.Store (cubic-feet)	Cum.Store (cubic-feet)
12.20	180	0	0
12.90	570	263	263

Device	Routing	Invert	Outlet Devices
#1	Primary	10.70'	10.0" Round Culvert L= 10.0' CPP, square edge headwall, Ke= 0.500 Inlet / Outlet Invert= 10.70' / 10.60' S= 0.0100 '/ Cc= 0.900 n= 0.013, Flow Area= 0.55 sf
#2	Discarded	12.20'	1.020 in/hr Exfiltration over Surface area Conductivity to Groundwater Elevation = 8.70'
#3	Device 1	12.80'	24inch-Dome Grate Capacity
#4	Primary	12.85'	5.0' long Sharp-Crested Rectangular Weir 2 End Contraction(s)

Discarded OutFlow Max=0.01 cfs @ 12.15 hrs HW=12.87' (Free Discharge)
 ↳ **2=Exfiltration** (Controls 0.01 cfs)

Primary OutFlow Max=0.31 cfs @ 12.15 hrs HW=12.87' (Free Discharge)
 ↳ **1=Culvert** (Passes 0.27 cfs of 3.47 cfs potential flow)
 ↳ **3=24inch-Dome Grate Capacity** (Custom Controls 0.27 cfs)
 ↳ **4=Sharp-Crested Rectangular Weir** (Weir Controls 0.03 cfs @ 0.42 fps)

14850_Proposed-Drainage-Areas_220609

NOAA 24-hr C NOAA 2-yr Rainfall=3.40"

Prepared by {enter your company name here}

Printed 6/16/2022

HydroCAD® 10.10-7a s/n 00546 © 2021 HydroCAD Software Solutions LLC

Page 90

Summary for Pond 4A-P: BB 4A - POND

Inflow Area = 4,843 sf, 86.37% Impervious, Inflow Depth = 2.84" for NOAA 2-yr event
 Inflow = 0.37 cfs @ 12.13 hrs, Volume= 1,147 cf
 Outflow = 0.35 cfs @ 12.15 hrs, Volume= 1,147 cf, Atten= 5%, Lag= 1.7 min
 Primary = 0.32 cfs @ 12.15 hrs, Volume= 307 cf
 Routed to Reach BMP_3 : BMP-3_OVERFLOW
 Secondary = 0.03 cfs @ 12.15 hrs, Volume= 839 cf
 Routed to Pond 4A-S : BB4A-Stone

Routing by Stor-Ind method, Time Span= 0.00-72.00 hrs, dt= 0.05 hrs
 Peak Elev= 10.02' @ 12.15 hrs Surf.Area= 560 sf Storage= 212 cf

Plug-Flow detention time= 34.1 min calculated for 1,147 cf (100% of inflow)
 Center-of-Mass det. time= 34.0 min (815.2 - 781.2)

Volume	Invert	Avail.Storage	Storage Description
#1	9.50'	320 cf	Custom Stage Data (Prismatic) Listed below (Recalc)
Elevation (feet)	Surf.Area (sq-ft)	Inc.Store (cubic-feet)	Cum.Store (cubic-feet)
9.50	250	0	0
10.20	664	320	320

Device	Routing	Invert	Outlet Devices
#1	Primary	8.00'	12.0" Round Culvert L= 10.0' CPP, square edge headwall, Ke= 0.500 Inlet / Outlet Invert= 8.00' / 7.90' S= 0.0100 '/ Cc= 0.900 n= 0.013, Flow Area= 0.79 sf
#2	Secondary	9.50'	2.410 in/hr Exfiltration over Surface area Conductivity to Groundwater Elevation = 6.00'
#3	Primary	10.10'	5.0' long Sharp-Crested Rectangular Weir 2 End Contraction(s)
#4	Device 1	9.95'	24inchDome Grate Capacity Head (feet) 0.00 0.05 0.10 0.15 0.20 0.25 0.30 0.35 0.40 0.45 0.50 0.55 0.60 0.65 0.70 0.75 0.80 0.85 0.90 0.95 1.00 1.05 1.10 Disch. (cfs) 0.000 0.180 0.460 0.850 1.360 1.830 2.420 3.100 3.600 3.800 4.000 4.200 4.380 4.600 4.750 4.900 5.100 5.200 5.350 5.450 5.650 5.800 5.950

Primary OutFlow Max=0.31 cfs @ 12.15 hrs HW=10.02' (Free Discharge)
 ↳ **1=Culvert** (Passes 0.31 cfs of 4.67 cfs potential flow)
 ↳ **4=24inchDome Grate Capacity** (Custom Controls 0.31 cfs)
 ↳ **3=Sharp-Crested Rectangular Weir** (Controls 0.00 cfs)

Secondary OutFlow Max=0.03 cfs @ 12.15 hrs HW=10.02' (Free Discharge)
 ↳ **2=Exfiltration** (Controls 0.03 cfs)

14850_Proposed-Drainage-Areas_220609

NOAA 24-hr C NOAA 2-yr Rainfall=3.40"

Prepared by {enter your company name here}

Printed 6/16/2022

HydroCAD® 10.10-7a s/n 00546 © 2021 HydroCAD Software Solutions LLC

Page 91

Summary for Pond 4A-S: BB4A-Stone

Inflow = 0.03 cfs @ 12.15 hrs, Volume= 839 cf
 Outflow = 0.03 cfs @ 12.20 hrs, Volume= 822 cf, Atten= 1%, Lag= 2.5 min
 Primary = 0.03 cfs @ 12.20 hrs, Volume= 822 cf
 Routed to Reach BMP4_O : BMP-4 OVERFLOW

Routing by Stor-Ind method, Time Span= 0.00-72.00 hrs, dt= 0.05 hrs
 Peak Elev= 7.12' @ 12.20 hrs Surf.Area= 230 sf Storage= 26 cf

Plug-Flow detention time= 29.1 min calculated for 821 cf (98% of inflow)
 Center-of-Mass det. time= 17.3 min (861.5 - 844.2)

Volume	Invert	Avail.Storage	Storage Description
#1	6.75'	138 cf	Custom Stage Data (Prismatic) Listed below (Recalc) 460 cf Overall x 30.0% Voids

Elevation (feet)	Surf.Area (sq-ft)	Inc.Store (cubic-feet)	Cum.Store (cubic-feet)
6.75	230	0	0
8.75	230	460	460

Device	Routing	Invert	Outlet Devices
#1	Primary	7.00'	4.0" Vert. Orifice/Grate C= 0.600 Limited to weir flow at low heads

Primary OutFlow Max=0.03 cfs @ 12.20 hrs HW=7.12' (Free Discharge)
 ↳ **1=Orifice/Grate** (Orifice Controls 0.03 cfs @ 1.19 fps)

14850_Proposed-Drainage-Areas_220609

NOAA 24-hr C NOAA 2-yr Rainfall=3.40"

Prepared by {enter your company name here}

Printed 6/16/2022

HydroCAD® 10.10-7a s/n 00546 © 2021 HydroCAD Software Solutions LLC

Page 92

Summary for Pond 4B-P: BB 4B - POND

Inflow Area = 3,048 sf, 86.09% Impervious, Inflow Depth = 2.84" for NOAA 2-yr event
 Inflow = 0.23 cfs @ 12.13 hrs, Volume= 722 cf
 Outflow = 0.23 cfs @ 12.15 hrs, Volume= 722 cf, Atten= 2%, Lag= 1.2 min
 Primary = 0.21 cfs @ 12.15 hrs, Volume= 199 cf
 Routed to Reach BMP4_O : BMP-4 OVERFLOW
 Secondary = 0.02 cfs @ 12.15 hrs, Volume= 522 cf
 Routed to Pond 4B-S : BB 4A-Stone

Routing by Stor-Ind method, Time Span= 0.00-72.00 hrs, dt= 0.05 hrs
 Peak Elev= 11.00' @ 12.15 hrs Surf.Area= 346 sf Storage= 124 cf

Plug-Flow detention time= 33.2 min calculated for 721 cf (100% of inflow)
 Center-of-Mass det. time= 33.2 min (814.4 - 781.2)

Volume	Invert	Avail.Storage	Storage Description
#1	10.50'	199 cf	Custom Stage Data (Prismatic) Listed below (Recalc)

Elevation (feet)	Surf.Area (sq-ft)	Inc.Store (cubic-feet)	Cum.Store (cubic-feet)
10.50	144	0	0
11.20	424	199	199

Device	Routing	Invert	Outlet Devices
#1	Primary	9.00'	12.0" Round Culvert L= 10.0' CPP, square edge headwall, Ke= 0.500 Inlet / Outlet Invert= 9.00' / 8.90' S= 0.0100 '/ S= 0.0100 '/ Cc= 0.900 n= 0.013, Flow Area= 0.79 sf
#2	Secondary	10.50'	2.410 in/hr Exfiltration over Surface area Conductivity to Groundwater Elevation = 7.00'
#3	Primary	11.10'	5.0' long Sharp-Crested Rectangular Weir 2 End Contraction(s)
#4	Device 1	10.95'	24inch-Dome Grate Capacity

Primary OutFlow Max=0.20 cfs @ 12.15 hrs HW=11.00' (Free Discharge)
 ↳ **1=Culvert** (Passes 0.20 cfs of 4.64 cfs potential flow)
 ↳ **4=24inch-Dome Grate Capacity** (Custom Controls 0.20 cfs)
 ↳ **3=Sharp-Crested Rectangular Weir** (Controls 0.00 cfs)

Secondary OutFlow Max=0.02 cfs @ 12.15 hrs HW=11.00' (Free Discharge)
 ↳ **2=Exfiltration** (Controls 0.02 cfs)

14850_Proposed-Drainage-Areas_220609

NOAA 24-hr C NOAA 2-yr Rainfall=3.40"

Prepared by {enter your company name here}

Printed 6/16/2022

HydroCAD® 10.10-7a s/n 00546 © 2021 HydroCAD Software Solutions LLC

Page 93

Summary for Pond 4B-S: BB 4A-Stone

Inflow = 0.02 cfs @ 12.15 hrs, Volume= 522 cf
 Outflow = 0.02 cfs @ 12.17 hrs, Volume= 512 cf, Atten= 0%, Lag= 1.6 min
 Primary = 0.02 cfs @ 12.17 hrs, Volume= 512 cf
 Routed to Reach BMP4_O : BMP-4 OVERFLOW

Routing by Stor-Ind method, Time Span= 0.00-72.00 hrs, dt= 0.05 hrs
 Peak Elev= 7.84' @ 12.17 hrs Surf.Area= 145 sf Storage= 15 cf

Plug-Flow detention time= 28.2 min calculated for 511 cf (98% of inflow)
 Center-of-Mass det. time= 16.2 min (860.8 - 844.6)

Volume	Invert	Avail.Storage	Storage Description
#1	7.50'	87 cf	Custom Stage Data (Prismatic) Listed below (Recalc) 290 cf Overall x 30.0% Voids

Elevation (feet)	Surf.Area (sq-ft)	Inc.Store (cubic-feet)	Cum.Store (cubic-feet)
7.50	145	0	0
9.50	145	290	290

Device	Routing	Invert	Outlet Devices
#1	Primary	7.75'	4.0" Vert. Orifice/Grate C= 0.600 Limited to weir flow at low heads

Primary OutFlow Max=0.02 cfs @ 12.17 hrs HW=7.84' (Free Discharge)
 ↑**1=Orifice/Grate** (Orifice Controls 0.02 cfs @ 1.04 fps)

14850_Proposed-Drainage-Areas_220609

NOAA 24-hr C NOAA 2-yr Rainfall=3.40"

Prepared by {enter your company name here}

Printed 6/16/2022

HydroCAD® 10.10-7a s/n 00546 © 2021 HydroCAD Software Solutions LLC

Page 94

Summary for Pond 5A-P: BB 5A - POND

Inflow Area = 3,072 sf, 73.44% Impervious, Inflow Depth = 2.54" for NOAA 2-yr event
 Inflow = 0.22 cfs @ 12.13 hrs, Volume= 651 cf
 Outflow = 0.04 cfs @ 12.59 hrs, Volume= 651 cf, Atten= 83%, Lag= 27.8 min
 Primary = 0.00 cfs @ 0.00 hrs, Volume= 0 cf
 Routed to Reach B : PARKING LOT B OVERFLOW
 Secondary = 0.04 cfs @ 12.59 hrs, Volume= 651 cf
 Routed to Pond 5A-PS : BB 5A-Stone

Routing by Stor-Ind method, Time Span= 0.00-72.00 hrs, dt= 0.05 hrs
 Peak Elev= 9.16' @ 12.59 hrs Surf.Area= 599 sf Storage= 195 cf

Plug-Flow detention time= 38.4 min calculated for 650 cf (100% of inflow)
 Center-of-Mass det. time= 38.4 min (836.6 - 798.2)

Volume	Invert	Avail.Storage	Storage Description
#1	8.80'	645 cf	Custom Stage Data (Prismatic) Listed below (Recalc)

Elevation (feet)	Surf.Area (sq-ft)	Inc.Store (cubic-feet)	Cum.Store (cubic-feet)
8.80	480	0	0
9.80	810	645	645

Device	Routing	Invert	Outlet Devices
#1	Primary	7.60'	12.0" Round Culvert L= 10.0' CPP, square edge headwall, Ke= 0.500 Inlet / Outlet Invert= 7.60' / 7.50' S= 0.0100 '/ S= 0.0100 '/ Cc= 0.900 n= 0.013, Flow Area= 0.79 sf
#2	Secondary	8.80'	2.410 in/hr Exfiltration over Surface area Conductivity to Groundwater Elevation = 5.60'
#3	Device 1	9.50'	24inch-Dome Grate Capacity

Primary OutFlow Max=0.00 cfs @ 0.00 hrs HW=8.80' (Free Discharge)
 ↑**1=Culvert** (Passes 0.00 cfs of 2.86 cfs potential flow)
 ↑**3=24inch-Dome Grate Capacity** (Controls 0.00 cfs)

Secondary OutFlow Max=0.04 cfs @ 12.59 hrs HW=9.16' (Free Discharge)
 ↑**2=Exfiltration** (Controls 0.04 cfs)

14850_Proposed-Drainage-Areas_220609

NOAA 24-hr C NOAA 2-yr Rainfall=3.40"

Prepared by {enter your company name here}

Printed 6/16/2022

HydroCAD® 10.10-7a s/n 00546 © 2021 HydroCAD Software Solutions LLC

Page 95

Summary for Pond 5A-PS: BB 5A-Stone

Inflow = 0.04 cfs @ 12.59 hrs, Volume= 651 cf
 Outflow = 0.04 cfs @ 12.67 hrs, Volume= 615 cf, Atten= 0%, Lag= 5.0 min
 Primary = 0.04 cfs @ 12.67 hrs, Volume= 615 cf
 Routed to Reach B : PARKING LOT B OVERFLOW

Routing by Stor-Ind method, Time Span= 0.00-72.00 hrs, dt= 0.05 hrs
 Peak Elev= 5.93' @ 12.67 hrs Surf.Area= 480 sf Storage= 54 cf

Plug-Flow detention time= 61.8 min calculated for 615 cf (94% of inflow)
 Center-of-Mass det. time= 31.8 min (868.4 - 836.6)

Volume	Invert	Avail.Storage	Storage Description
#1	5.55'	288 cf	Custom Stage Data (Prismatic) Listed below (Recalc) 960 cf Overall x 30.0% Voids

Elevation (feet)	Surf.Area (sq-ft)	Inc.Store (cubic-feet)	Cum.Store (cubic-feet)
5.55	480	0	0
7.55	480	960	960

Device	Routing	Invert	Outlet Devices
#1	Primary	5.80'	4.0" Vert. Orifice/Grate C= 0.600 Limited to weir flow at low heads

Primary OutFlow Max=0.04 cfs @ 12.67 hrs HW=5.93' (Free Discharge)
 ↳ **1=Orifice/Grate** (Orifice Controls 0.04 cfs @ 1.21 fps)

14850_Proposed-Drainage-Areas_220609

NOAA 24-hr C NOAA 2-yr Rainfall=3.40"

Prepared by {enter your company name here}

Printed 6/16/2022

HydroCAD® 10.10-7a s/n 00546 © 2021 HydroCAD Software Solutions LLC

Page 96

Summary for Pond 5B-P: BB 5B - POND

Inflow Area = 34,755 sf, 71.39% Impervious, Inflow Depth = 2.45" for NOAA 2-yr event
 Inflow = 2.40 cfs @ 12.13 hrs, Volume= 7,086 cf
 Outflow = 2.35 cfs @ 12.15 hrs, Volume= 7,086 cf, Atten= 2%, Lag= 1.2 min
 Primary = 0.57 cfs @ 12.15 hrs, Volume= 267 cf
 Routed to Reach B : PARKING LOT B OVERFLOW
 Secondary = 0.09 cfs @ 12.15 hrs, Volume= 3,100 cf
 Routed to Pond 5B-PS : BB 5B-Stone
 Tertiary = 1.68 cfs @ 12.15 hrs, Volume= 3,719 cf
 Routed to Reach 6R : ISOLATOR ROW 2

Routing by Stor-Ind method, Time Span= 0.00-72.00 hrs, dt= 0.05 hrs
 Peak Elev= 8.97' @ 12.15 hrs Surf.Area= 1,407 sf Storage= 667 cf

Plug-Flow detention time= 32.0 min calculated for 7,086 cf (100% of inflow)
 Center-of-Mass det. time= 32.0 min (835.0 - 803.0)

Volume	Invert	Avail.Storage	Storage Description
#1	8.20'	711 cf	Custom Stage Data (Prismatic) Listed below (Recalc)

Elevation (feet)	Surf.Area (sq-ft)	Inc.Store (cubic-feet)	Cum.Store (cubic-feet)
8.20	327	0	0
9.00	1,450	711	711

Device	Routing	Invert	Outlet Devices
#1	Primary	7.00'	12.0" Round Culvert L= 10.0' CPP, square edge headwall, Ke= 0.500 Inlet / Outlet Invert= 7.00' / 6.90' S= 0.0100 '/ Cc= 0.900 n= 0.013, Flow Area= 0.79 sf
#2	Secondary	8.20'	2.410 in/hr Exfiltration over Surface area Conductivity to Groundwater Elevation = 5.00'
#3	Device 1	8.90'	24inchDome Grate Capacity X 2.00 Head (feet) 0.00 0.05 0.10 0.15 0.20 0.25 0.30 0.35 0.40 0.45 0.50 0.55 0.60 0.65 0.70 0.75 0.80 0.85 0.90 0.95 1.00 1.05 1.10 Disch. (cfs) 0.000 0.180 0.460 0.850 1.360 1.830 2.420 3.100 3.600 3.800 4.000 4.200 4.380 4.600 4.750 4.900 5.100 5.200 5.350 5.450 5.650 5.800 5.950
#4	Tertiary	8.70'	15inch-Dome Grate Capacity

Primary OutFlow Max=0.57 cfs @ 12.15 hrs HW=8.97' (Free Discharge)
 ↳ **1=Culvert** (Passes 0.57 cfs of 4.58 cfs potential flow)
 ↳ **3=24inchDome Grate Capacity** (Custom Controls 0.57 cfs)

Secondary OutFlow Max=0.09 cfs @ 12.15 hrs HW=8.97' (Free Discharge)
 ↳ **2=Exfiltration** (Controls 0.09 cfs)

Tertiary OutFlow Max=1.67 cfs @ 12.15 hrs HW=8.97' (Free Discharge)
 ↳ **4=15inch-Dome Grate Capacity** (Custom Controls 1.67 cfs)

14850_Proposed-Drainage-Areas_220609

NOAA 24-hr C NOAA 2-yr Rainfall=3.40"

Prepared by {enter your company name here}

Printed 6/16/2022

HydroCAD® 10.10-7a s/n 00546 © 2021 HydroCAD Software Solutions LLC

Page 97

Summary for Pond 5B-PS: BB 5B-Stone

Inflow = 0.09 cfs @ 12.15 hrs, Volume= 3,100 cf
 Outflow = 0.09 cfs @ 12.21 hrs, Volume= 3,048 cf, Atten= 3%, Lag= 3.8 min
 Primary = 0.09 cfs @ 12.21 hrs, Volume= 3,048 cf
 Routed to Reach B : PARKING LOT B OVERFLOW

Routing by Stor-Ind method, Time Span= 0.00-72.00 hrs, dt= 0.05 hrs
 Peak Elev= 5.45' @ 12.21 hrs Surf.Area= 690 sf Storage= 94 cf

Plug-Flow detention time= 28.7 min calculated for 3,046 cf (98% of inflow)
 Center-of-Mass det. time= 20.1 min (972.8 - 952.7)

Volume	Invert	Avail.Storage	Storage Description
#1	5.00'	414 cf	Custom Stage Data (Prismatic) Listed below (Recalc) 1,380 cf Overall x 30.0% Voids

Elevation (feet)	Surf.Area (sq-ft)	Inc.Store (cubic-feet)	Cum.Store (cubic-feet)
5.00	690	0	0
7.00	690	1,380	1,380

Device	Routing	Invert	Outlet Devices
#1	Primary	5.25'	4.0" Vert. Orifice/Grate C= 0.600 Limited to weir flow at low heads

Primary OutFlow Max=0.09 cfs @ 12.21 hrs HW=5.45' (Free Discharge)
 ↳ **1=Orifice/Grate** (Orifice Controls 0.09 cfs @ 1.54 fps)

14850_Proposed-Drainage-Areas_220609

NOAA 24-hr C NOAA 2-yr Rainfall=3.40"

Prepared by {enter your company name here}

Printed 6/16/2022

HydroCAD® 10.10-7a s/n 00546 © 2021 HydroCAD Software Solutions LLC

Page 98

Summary for Pond 6A-P: BB 6A - POND

Inflow Area = 15,148 sf, 46.97% Impervious, Inflow Depth = 1.93" for NOAA 2-yr event
 Inflow = 0.85 cfs @ 12.13 hrs, Volume= 2,436 cf
 Outflow = 0.82 cfs @ 12.15 hrs, Volume= 2,436 cf, Atten= 4%, Lag= 1.3 min
 Primary = 0.77 cfs @ 12.15 hrs, Volume= 996 cf
 Routed to Reach BMP6_O : BMP-6 OVERFLOW
 Secondary = 0.04 cfs @ 12.15 hrs, Volume= 1,440 cf
 Routed to Pond 6A-PS : BB 6A - STONE

Routing by Stor-Ind method, Time Span= 0.00-72.00 hrs, dt= 0.05 hrs
 Peak Elev= 10.94' @ 12.15 hrs Surf.Area= 671 sf Storage= 378 cf

Plug-Flow detention time= 47.5 min calculated for 2,434 cf (100% of inflow)
 Center-of-Mass det. time= 47.4 min (874.1 - 826.6)

Volume	Invert	Avail.Storage	Storage Description
#1	10.20'	491 cf	Custom Stage Data (Prismatic) Listed below (Recalc)

Elevation (feet)	Surf.Area (sq-ft)	Inc.Store (cubic-feet)	Cum.Store (cubic-feet)
10.20	350	0	0
11.10	740	491	491

Device	Routing	Invert	Outlet Devices
#1	Primary	9.00'	12.0" Round Culvert L= 10.0' CPP, square edge headwall, Ke= 0.500 Inlet / Outlet Invert= 9.00' / 8.90' S= 0.0100 '/ S= 0.0100 '/ Cc= 0.900 n= 0.013, Flow Area= 0.79 sf
#2	Secondary	10.20'	2.410 in/hr Exfiltration over Surface area Conductivity to Groundwater Elevation = 7.00'
#3	Device 1	10.80'	24inch-Dome Grate Capacity
#4	Primary	11.00'	5.0' long Sharp-Crested Rectangular Weir 2 End Contraction(s)

Primary OutFlow Max=0.77 cfs @ 12.15 hrs HW=10.94' (Free Discharge)

↳ **1=Culvert** (Passes 0.77 cfs of 4.54 cfs potential flow)
 ↳ **3=24inch-Dome Grate Capacity** (Custom Controls 0.77 cfs)
 ↳ **4=Sharp-Crested Rectangular Weir** (Controls 0.00 cfs)

Secondary OutFlow Max=0.04 cfs @ 12.15 hrs HW=10.94' (Free Discharge)

↳ **2=Exfiltration** (Controls 0.04 cfs)

14850_Proposed-Drainage-Areas_220609

NOAA 24-hr C NOAA 2-yr Rainfall=3.40"

Prepared by {enter your company name here}

Printed 6/16/2022

HydroCAD® 10.10-7a s/n 00546 © 2021 HydroCAD Software Solutions LLC

Page 99

Summary for Pond 6A-PS: BB 6A - STONE

Inflow = 0.04 cfs @ 12.15 hrs, Volume= 1,440 cf
 Outflow = 0.04 cfs @ 12.20 hrs, Volume= 1,418 cf, Atten= 1%, Lag= 2.6 min
 Primary = 0.04 cfs @ 12.20 hrs, Volume= 1,418 cf
 Routed to Reach BMP6_O : BMP-6 OVERFLOW

Routing by Stor-Ind method, Time Span= 0.00-72.00 hrs, dt= 0.05 hrs
 Peak Elev= 7.39' @ 12.20 hrs Surf.Area= 290 sf Storage= 34 cf

Plug-Flow detention time= 19.4 min calculated for 1,417 cf (98% of inflow)
 Center-of-Mass det. time= 12.3 min (976.6 - 964.3)

Volume	Invert	Avail.Storage	Storage Description
#1	7.00'	174 cf	Custom Stage Data (Prismatic) Listed below (Recalc) 580 cf Overall x 30.0% Voids

Elevation (feet)	Surf.Area (sq-ft)	Inc.Store (cubic-feet)	Cum.Store (cubic-feet)
7.00	290	0	0
9.00	290	580	580

Device	Routing	Invert	Outlet Devices
#1	Primary	7.25'	4.0" Vert. Orifice/Grate C= 0.600 Limited to weir flow at low heads

Primary OutFlow Max=0.04 cfs @ 12.20 hrs HW=7.39' (Free Discharge)
 ↳1=Orifice/Grate (Orifice Controls 0.04 cfs @ 1.27 fps)

14850_Proposed-Drainage-Areas_220609

NOAA 24-hr C NOAA 2-yr Rainfall=3.40"

Prepared by {enter your company name here}

Printed 6/16/2022

HydroCAD® 10.10-7a s/n 00546 © 2021 HydroCAD Software Solutions LLC

Page 100

Summary for Pond 6B-P: BB 6B

Inflow Area = 6,495 sf, 77.45% Impervious, Inflow Depth = 2.64" for NOAA 2-yr event
 Inflow = 0.47 cfs @ 12.13 hrs, Volume= 1,428 cf
 Outflow = 0.44 cfs @ 12.15 hrs, Volume= 1,428 cf, Atten= 6%, Lag= 1.6 min
 Discarded = 0.02 cfs @ 12.15 hrs, Volume= 871 cf
 Primary = 0.43 cfs @ 12.15 hrs, Volume= 557 cf
 Routed to Reach BMP6_O : BMP-6 OVERFLOW

Routing by Stor-Ind method, Time Span= 0.00-72.00 hrs, dt= 0.05 hrs
 Peak Elev= 12.04' @ 12.15 hrs Surf.Area= 658 sf Storage= 356 cf

Plug-Flow detention time= 135.2 min calculated for 1,427 cf (100% of inflow)
 Center-of-Mass det. time= 135.3 min (928.4 - 793.1)

Volume	Invert	Avail.Storage	Storage Description
#1	11.20'	394 cf	Custom Stage Data (Prismatic) Listed below (Recalc)

Elevation (feet)	Surf.Area (sq-ft)	Inc.Store (cubic-feet)	Cum.Store (cubic-feet)
11.20	185	0	0
12.10	690	394	394

Device	Routing	Invert	Outlet Devices
#1	Primary	10.10'	12.0" Round Culvert L= 10.0' CPP, square edge headwall, Ke= 0.500 Inlet / Outlet Invert= 10.10' / 10.00' S= 0.0100 ' / Cc= 0.900 n= 0.013, Flow Area= 0.79 sf
#2	Discarded	11.20'	1.020 in/hr Exfiltration over Surface area Conductivity to Groundwater Elevation = 8.10'
#3	Device 1	11.95'	24inch-Dome Grate Capacity

Discarded OutFlow Max=0.02 cfs @ 12.15 hrs HW=12.04' (Free Discharge)
 ↳2=Exfiltration (Controls 0.02 cfs)

Primary OutFlow Max=0.42 cfs @ 12.15 hrs HW=12.04' (Free Discharge)
 ↳1=Culvert (Passes 0.42 cfs of 4.54 cfs potential flow)
 ↳3=24inch-Dome Grate Capacity (Custom Controls 0.42 cfs)

14850_Proposed-Drainage-Areas_220609

NOAA 24-hr C NOAA 2-yr Rainfall=3.40"

Prepared by {enter your company name here}

Printed 6/16/2022

HydroCAD® 10.10-7a s/n 00546 © 2021 HydroCAD Software Solutions LLC

Page 101

Summary for Pond 7A-P: BB 7A PONDING

Inflow Area = 3,165 sf, 87.74% Impervious, Inflow Depth = 2.84" for NOAA 2-yr event
 Inflow = 0.24 cfs @ 12.13 hrs, Volume= 749 cf
 Outflow = 0.24 cfs @ 12.15 hrs, Volume= 749 cf, Atten= 1%, Lag= 1.1 min
 Primary = 0.22 cfs @ 12.15 hrs, Volume= 210 cf
 Routed to Reach 7R : PARKING LOT C to HUDSON
 Secondary = 0.02 cfs @ 12.14 hrs, Volume= 539 cf
 Routed to Pond 7A-S : BB 7A - STONE

Routing by Stor-Ind method, Time Span= 0.00-72.00 hrs, dt= 0.05 hrs
 Peak Elev= 9.96' @ 12.14 hrs Surf.Area= 316 sf Storage= 141 cf

Plug-Flow detention time= 43.9 min calculated for 749 cf (100% of inflow)
 Center-of-Mass det. time= 43.9 min (825.1 - 781.2)

Volume	Invert	Avail.Storage	Storage Description
#1	9.30'	227 cf	Custom Stage Data (Prismatic) Listed below (Recalc)
Elevation (feet)	Surf.Area (sq-ft)	Inc.Store (cubic-feet)	Cum.Store (cubic-feet)
9.30	115	0	0
10.20	390	227	227

Device	Routing	Invert	Outlet Devices
#1	Primary	8.10'	12.0" Round Culvert L= 10.0' CPP, square edge headwall, Ke= 0.500 Inlet / Outlet Invert= 8.10' / 8.00' S= 0.0100 '/ Cc= 0.900 n= 0.013, Flow Area= 0.79 sf
#2	Secondary	9.30'	2.410 in/hr Exfiltration over Surface area Conductivity to Groundwater Elevation = 6.10'
#3	Device 1	9.90'	24inch-Dome Grate Capacity
#4	Primary	10.10'	5.0' long Sharp-Crested Rectangular Weir 2 End Contraction(s)

Primary OutFlow Max=0.22 cfs @ 12.15 hrs HW=9.96' (Free Discharge)

- 1=Culvert (Passes 0.22 cfs of 4.40 cfs potential flow)
- 3=24inch-Dome Grate Capacity (Custom Controls 0.22 cfs)
- 4=Sharp-Crested Rectangular Weir (Controls 0.00 cfs)

Secondary OutFlow Max=0.02 cfs @ 12.14 hrs HW=9.96' (Free Discharge)

- 2=Exfiltration (Controls 0.02 cfs)

14850_Proposed-Drainage-Areas_220609

NOAA 24-hr C NOAA 2-yr Rainfall=3.40"

Prepared by {enter your company name here}

Printed 6/16/2022

HydroCAD® 10.10-7a s/n 00546 © 2021 HydroCAD Software Solutions LLC

Page 102

Summary for Pond 7A-S: BB 7A - STONE

Inflow = 0.02 cfs @ 12.14 hrs, Volume= 539 cf
 Outflow = 0.02 cfs @ 12.18 hrs, Volume= 539 cf, Atten= 0%, Lag= 1.9 min
 Primary = 0.02 cfs @ 12.18 hrs, Volume= 539 cf
 Routed to Reach 7R : PARKING LOT C to HUDSON

Routing by Stor-Ind method, Time Span= 0.00-72.00 hrs, dt= 0.05 hrs
 Peak Elev= 5.19' @ 12.18 hrs Surf.Area= 150 sf Storage= 4 cf

Plug-Flow detention time= 5.1 min calculated for 539 cf (100% of inflow)
 Center-of-Mass det. time= 5.1 min (864.8 - 859.7)

Volume	Invert	Avail.Storage	Storage Description
#1	5.10'	90 cf	Custom Stage Data (Prismatic) Listed below (Recalc) 300 cf Overall x 30.0% Voids

Elevation (feet)	Surf.Area (sq-ft)	Inc.Store (cubic-feet)	Cum.Store (cubic-feet)
5.10	150	0	0
7.10	150	300	300

Device	Routing	Invert	Outlet Devices
#1	Primary	5.10'	4.0" Vert. Orifice/Grate C= 0.600 Limited to weir flow at low heads

Primary OutFlow Max=0.02 cfs @ 12.18 hrs HW=5.19' (Free Discharge)

- 1=Orifice/Grate (Orifice Controls 0.02 cfs @ 1.03 fps)

14850_Proposed-Drainage-Areas_220609

NOAA 24-hr C NOAA 2-yr Rainfall=3.40"

Prepared by {enter your company name here}

Printed 6/16/2022

HydroCAD® 10.10-7a s/n 00546 © 2021 HydroCAD Software Solutions LLC

Page 103

Summary for Pond 7B-P: BB 7B PONDING

Inflow Area = 4,942 sf, 88.73% Impervious, Inflow Depth = 2.84" for NOAA 2-yr event
 Inflow = 0.38 cfs @ 12.13 hrs, Volume= 1,170 cf
 Outflow = 0.37 cfs @ 12.16 hrs, Volume= 1,170 cf, Atten= 3%, Lag= 2.1 min
 Primary = 0.33 cfs @ 12.16 hrs, Volume= 283 cf
 Routed to Reach BMP7_O : BMP-7 OVERFLOW
 Secondary = 0.03 cfs @ 12.16 hrs, Volume= 887 cf
 Routed to Pond 7B-S : BB 7B - STONE

Routing by Stor-Ind method, Time Span= 0.00-72.00 hrs, dt= 0.05 hrs
 Peak Elev= 10.68' @ 12.16 hrs Surf.Area= 512 sf Storage= 258 cf

Plug-Flow detention time= 47.2 min calculated for 1,170 cf (100% of inflow)
 Center-of-Mass det. time= 47.2 min (828.4 - 781.2)

Volume	Invert	Avail.Storage	Storage Description
#1	10.00'	324 cf	Custom Stage Data (Prismatic) Listed below (Recalc)
Elevation (feet)	Surf.Area (sq-ft)	Inc.Store (cubic-feet)	Cum.Store (cubic-feet)
10.00	250	0	0
10.80	560	324	324

Device	Routing	Invert	Outlet Devices
#1	Primary	8.90'	12.0" Round Culvert L= 10.0' CPP, square edge headwall, Ke= 0.500 Inlet / Outlet Invert= 8.90' / 8.80' S= 0.0100 '/ Cc= 0.900 n= 0.013, Flow Area= 0.79 sf
#2	Secondary	10.00'	2.410 in/hr Exfiltration over Surface area Conductivity to Groundwater Elevation = 6.90'
#3	Device 1	10.60'	24inch-Dome Grate Capacity

Primary OutFlow Max=0.31 cfs @ 12.16 hrs HW=10.67' (Free Discharge)
 ↳1=Culvert (Passes 0.31 cfs of 4.27 cfs potential flow)
 ↳3=24inch-Dome Grate Capacity (Custom Controls 0.31 cfs)

Secondary OutFlow Max=0.03 cfs @ 12.16 hrs HW=10.67' (Free Discharge)
 ↳2=Exfiltration (Controls 0.03 cfs)

14850_Proposed-Drainage-Areas_220609

NOAA 24-hr C NOAA 2-yr Rainfall=3.40"

Prepared by {enter your company name here}

Printed 6/16/2022

HydroCAD® 10.10-7a s/n 00546 © 2021 HydroCAD Software Solutions LLC

Page 104

Summary for Pond 7B-S: BB 7B - STONE

Inflow = 0.03 cfs @ 12.16 hrs, Volume= 887 cf
 Outflow = 0.03 cfs @ 12.19 hrs, Volume= 875 cf, Atten= 1%, Lag= 1.9 min
 Primary = 0.03 cfs @ 12.19 hrs, Volume= 875 cf
 Routed to Reach BMP7_O : BMP-7 OVERFLOW

Routing by Stor-Ind method, Time Span= 0.00-72.00 hrs, dt= 0.05 hrs
 Peak Elev= 7.62' @ 12.19 hrs Surf.Area= 150 sf Storage= 17 cf

Plug-Flow detention time= 18.8 min calculated for 875 cf (99% of inflow)
 Center-of-Mass det. time= 11.3 min (868.7 - 857.4)

Volume	Invert	Avail.Storage	Storage Description
#1	7.25'	90 cf	Custom Stage Data (Prismatic) Listed below (Recalc) 300 cf Overall x 30.0% Voids

Elevation (feet)	Surf.Area (sq-ft)	Inc.Store (cubic-feet)	Cum.Store (cubic-feet)
7.25	150	0	0
9.25	150	300	300

Device	Routing	Invert	Outlet Devices
#1	Primary	7.50'	4.0" Vert. Orifice/Grate C= 0.600 Limited to weir flow at low heads

Primary OutFlow Max=0.03 cfs @ 12.19 hrs HW=7.62' (Free Discharge)
 ↳1=Orifice/Grate (Orifice Controls 0.03 cfs @ 1.17 fps)

14850_Proposed-Drainage-Areas_220609

NOAA 24-hr C NOAA 2-yr Rainfall=3.40"

Prepared by {enter your company name here}

Printed 6/16/2022

HydroCAD® 10.10-7a s/n 00546 © 2021 HydroCAD Software Solutions LLC

Page 105

Summary for Pond 8a-P: BB 8A PONDING

Inflow Area = 3,978 sf, 79.99% Impervious, Inflow Depth = 2.64" for NOAA 2-yr event
 Inflow = 0.29 cfs @ 12.13 hrs, Volume= 875 cf
 Outflow = 0.14 cfs @ 12.27 hrs, Volume= 875 cf, Atten= 52%, Lag= 8.5 min
 Primary = 0.10 cfs @ 12.27 hrs, Volume= 79 cf
 Routed to Reach P ST : PORTLAND STREET DRAINAGE
 Secondary = 0.04 cfs @ 12.27 hrs, Volume= 795 cf
 Routed to Pond 8a-s : BB 8A - STONE

Routing by Stor-Ind method, Time Span= 0.00-72.00 hrs, dt= 0.05 hrs
 Peak Elev= 9.03' @ 12.27 hrs Surf.Area= 587 sf Storage= 250 cf

Plug-Flow detention time= 47.4 min calculated for 874 cf (100% of inflow)
 Center-of-Mass det. time= 47.3 min (840.4 - 793.1)

Volume	Invert	Avail.Storage	Storage Description
#1	8.50'	575 cf	Custom Stage Data (Prismatic) Listed below (Recalc)
Elevation (feet)	Surf.Area (sq-ft)	Inc.Store (cubic-feet)	Cum.Store (cubic-feet)
8.50	360	0	0
9.50	790	575	575

Device	Routing	Invert	Outlet Devices
#1	Primary	7.40'	12.0" Round Culvert L= 10.0' CPP, square edge headwall, Ke= 0.500 Inlet / Outlet Invert= 7.40' / 7.30' S= 0.0100 1' Cc= 0.900 n= 0.013, Flow Area= 0.79 sf
#2	Secondary	8.50'	2.410 in/hr Exfiltration over Surface area Conductivity to Groundwater Elevation = 5.40'
#3	Device 1	9.00'	24inch-Dome Grate Capacity
#4	Primary	9.40'	5.0' long Sharp-Crested Rectangular Weir 2 End Contraction(s)

Primary OutFlow Max=0.09 cfs @ 12.27 hrs HW=9.03' (Free Discharge)

↑**1=Culvert** (Passes 0.09 cfs of 3.99 cfs potential flow)

↑**3=24inch-Dome Grate Capacity** (Custom Controls 0.09 cfs)

↑**4=Sharp-Crested Rectangular Weir** (Controls 0.00 cfs)

Secondary OutFlow Max=0.04 cfs @ 12.27 hrs HW=9.03' (Free Discharge)

↑**2=Exfiltration** (Controls 0.04 cfs)

14850_Proposed-Drainage-Areas_220609

NOAA 24-hr C NOAA 2-yr Rainfall=3.40"

Prepared by {enter your company name here}

Printed 6/16/2022

HydroCAD® 10.10-7a s/n 00546 © 2021 HydroCAD Software Solutions LLC

Page 106

Summary for Pond 8a-s: BB 8A - STONE

Inflow = 0.04 cfs @ 12.27 hrs, Volume= 795 cf
 Outflow = 0.04 cfs @ 12.35 hrs, Volume= 777 cf, Atten= 1%, Lag= 5.1 min
 Primary = 0.04 cfs @ 12.35 hrs, Volume= 777 cf
 Routed to Reach P ST : PORTLAND STREET DRAINAGE

Routing by Stor-Ind method, Time Span= 0.00-72.00 hrs, dt= 0.05 hrs
 Peak Elev= 5.63' @ 12.35 hrs Surf.Area= 300 sf Storage= 29 cf

Plug-Flow detention time= 30.8 min calculated for 777 cf (98% of inflow)
 Center-of-Mass det. time= 18.1 min (868.3 - 850.2)

Volume	Invert	Avail.Storage	Storage Description
#1	5.30'	180 cf	Custom Stage Data (Prismatic) Listed below (Recalc) 600 cf Overall x 30.0% Voids

Elevation (feet)	Surf.Area (sq-ft)	Inc.Store (cubic-feet)	Cum.Store (cubic-feet)
5.30	300	0	0
7.30	300	600	600

Device	Routing	Invert	Outlet Devices
#1	Primary	5.50'	4.0" Vert. Orifice/Grate C= 0.600 Limited to weir flow at low heads

Primary OutFlow Max=0.04 cfs @ 12.35 hrs HW=5.63' (Free Discharge)

↑**1=Orifice/Grate** (Orifice Controls 0.04 cfs @ 1.21 fps)

14850_Proposed-Drainage-Areas_220609

NOAA 24-hr C NOAA 2-yr Rainfall=3.40"

Prepared by {enter your company name here}

Printed 6/16/2022

HydroCAD® 10.10-7a s/n 00546 © 2021 HydroCAD Software Solutions LLC

Page 107

Summary for Pond 8B-P: BB 8B-PONDING

Inflow Area = 5,598 sf, 87.78% Impervious, Inflow Depth = 2.84" for NOAA 2-yr event
 Inflow = 0.43 cfs @ 12.13 hrs, Volume= 1,325 cf
 Outflow = 0.41 cfs @ 12.15 hrs, Volume= 1,325 cf, Atten= 3%, Lag= 1.2 min
 Primary = 0.38 cfs @ 12.15 hrs, Volume= 364 cf
 Routed to Reach 7R : PARKING LOT C to HUDSON
 Secondary = 0.04 cfs @ 12.15 hrs, Volume= 962 cf
 Routed to Pond 8B-S : BB 8B-Stone

Routing by Stor-Ind method, Time Span= 0.00-72.00 hrs, dt= 0.05 hrs
 Peak Elev= 9.70' @ 12.15 hrs Surf.Area= 615 sf Storage= 242 cf

Plug-Flow detention time= 39.5 min calculated for 1,325 cf (100% of inflow)
 Center-of-Mass det. time= 39.4 min (820.6 - 781.2)

Volume	Invert	Avail.Storage	Storage Description
#1	9.10'	306 cf	Custom Stage Data (Prismatic) Listed below (Recalc)
Elevation (feet)	Surf.Area (sq-ft)	Inc.Store (cubic-feet)	Cum.Store (cubic-feet)
9.10	190	0	0
9.80	685	306	306

Device	Routing	Invert	Outlet Devices
#1	Primary	7.90'	12.0" Round Culvert L= 10.0' CPP, square edge headwall, Ke= 0.500 Inlet / Outlet Invert= 7.90' / 7.80' S= 0.0100 '/ Cc= 0.900 n= 0.013, Flow Area= 0.79 sf
#2	Secondary	9.10'	2.410 in/hr Exfiltration over Surface area Conductivity to Groundwater Elevation = 5.90'
#3	Device 1	9.65'	24inch-Dome Grate Capacity X 2.00

Primary OutFlow Max=0.37 cfs @ 12.15 hrs HW=9.70' (Free Discharge)

↑1=Culvert (Passes 0.37 cfs of 4.31 cfs potential flow)

↑3=24inch-Dome Grate Capacity (Custom Controls 0.37 cfs)

Secondary OutFlow Max=0.04 cfs @ 12.15 hrs HW=9.70' (Free Discharge)

↑2=Exfiltration (Controls 0.04 cfs)

14850_Proposed-Drainage-Areas_220609

NOAA 24-hr C NOAA 2-yr Rainfall=3.40"

Prepared by {enter your company name here}

Printed 6/16/2022

HydroCAD® 10.10-7a s/n 00546 © 2021 HydroCAD Software Solutions LLC

Page 108

Summary for Pond 8B-S: BB 8B-Stone

Inflow = 0.04 cfs @ 12.15 hrs, Volume= 962 cf
 Outflow = 0.04 cfs @ 12.20 hrs, Volume= 935 cf, Atten= 1%, Lag= 3.0 min
 Primary = 0.04 cfs @ 12.20 hrs, Volume= 935 cf
 Routed to Reach 7R : PARKING LOT C to HUDSON

Routing by Stor-Ind method, Time Span= 0.00-72.00 hrs, dt= 0.05 hrs
 Peak Elev= 6.33' @ 12.20 hrs Surf.Area= 300 sf Storage= 39 cf

Plug-Flow detention time= 38.5 min calculated for 935 cf (97% of inflow)
 Center-of-Mass det. time= 22.5 min (875.4 - 852.9)

Volume	Invert	Avail.Storage	Storage Description
#1	5.90'	180 cf	Custom Stage Data (Prismatic) Listed below (Recalc) 600 cf Overall x 30.0% Voids

Elevation (feet)	Surf.Area (sq-ft)	Inc.Store (cubic-feet)	Cum.Store (cubic-feet)
5.90	300	0	0
7.90	300	600	600

Device	Routing	Invert	Outlet Devices
#1	Primary	6.20'	4.0" Vert. Orifice/Grate C= 0.600 Limited to weir flow at low heads

Primary OutFlow Max=0.04 cfs @ 12.20 hrs HW=6.33' (Free Discharge)

↑1=Orifice/Grate (Orifice Controls 0.04 cfs @ 1.22 fps)

14850_Proposed-Drainage-Areas_220609

NOAA 24-hr C NOAA 2-yr Rainfall=3.40"

Prepared by {enter your company name here}

Printed 6/16/2022

HydroCAD® 10.10-7a s/n 00546 © 2021 HydroCAD Software Solutions LLC

Page 109

Summary for Pond 9-P: BB9 - POND

Inflow Area = 29,651 sf, 74.77% Impervious, Inflow Depth = 2.54" for NOAA 2-yr event
 Inflow = 2.10 cfs @ 12.13 hrs, Volume= 6,279 cf
 Outflow = 2.05 cfs @ 12.15 hrs, Volume= 6,279 cf, Atten= 3%, Lag= 1.1 min
 Primary = 0.01 cfs @ 12.15 hrs, Volume= 2 cf
 Routed to Reach BMP9_O : BMP-9 OVERFLOW
 Secondary = 0.04 cfs @ 12.15 hrs, Volume= 1,929 cf
 Routed to Pond 9-PS : BB9 - STONE
 Tertiary = 2.00 cfs @ 12.15 hrs, Volume= 4,348 cf
 Routed to Reach 1R : ISOLATOR ROW C

Routing by Stor-Ind method, Time Span= 0.00-72.00 hrs, dt= 0.05 hrs
 Peak Elev= 8.80' @ 12.15 hrs Surf.Area= 664 sf Storage= 343 cf

Plug-Flow detention time= 26.2 min calculated for 6,275 cf (100% of inflow)
 Center-of-Mass det. time= 26.2 min (824.4 - 798.2)

Volume	Invert	Avail.Storage	Storage Description
#1	8.00'	485 cf	Custom Stage Data (Prismatic) Listed below (Recalc)

Elevation (feet)	Surf.Area (sq-ft)	Inc.Store (cubic-feet)	Cum.Store (cubic-feet)
8.00	190	0	0
9.00	780	485	485

Device	Routing	Invert	Outlet Devices
#1	Primary	7.00'	12.0" Round Culvert L= 10.0' CPP, square edge headwall, Ke= 0.500 Inlet / Outlet Invert= 7.00' / 6.90' S= 0.0100 '/ Cc= 0.900 n= 0.013, Flow Area= 0.79 sf
#2	Secondary	8.00'	2.410 in/hr Exfiltration over Surface area Conductivity to Groundwater Elevation = 5.00'
#3	Device 1	8.80'	24inchDome Grate Capacity Head (feet) 0.00 0.05 0.10 0.15 0.20 0.25 0.30 0.35 0.40 0.45 0.50 0.55 0.60 0.65 0.70 0.75 0.80 0.85 0.90 0.95 1.00 1.05 1.10 Disch. (cfs) 0.000 0.180 0.460 0.850 1.360 1.830 2.420 3.100 3.600 3.800 4.000 4.200 4.380 4.600 4.750 4.900 5.100 5.200 5.350 5.450 5.650 5.800 5.950
#4	Tertiary	8.50'	15inch-Dome Grate Capacity

Primary OutFlow Max=0.01 cfs @ 12.15 hrs HW=8.80' (Free Discharge)

↳1=Culvert (Passes 0.01 cfs of 4.32 cfs potential flow)

↳3=24inchDome Grate Capacity (Custom Controls 0.01 cfs)

Secondary OutFlow Max=0.04 cfs @ 12.15 hrs HW=8.80' (Free Discharge)

↳2=Exfiltration (Controls 0.04 cfs)

Tertiary OutFlow Max=1.98 cfs @ 12.15 hrs HW=8.80' (Free Discharge)

↳4=15inch-Dome Grate Capacity (Custom Controls 1.98 cfs)

14850_Proposed-Drainage-Areas_220609

NOAA 24-hr C NOAA 2-yr Rainfall=3.40"

Prepared by {enter your company name here}

Printed 6/16/2022

HydroCAD® 10.10-7a s/n 00546 © 2021 HydroCAD Software Solutions LLC

Page 110

Summary for Pond 9-PS: BB9 - STONE

Inflow = 0.04 cfs @ 12.15 hrs, Volume= 1,929 cf
 Outflow = 0.04 cfs @ 12.17 hrs, Volume= 1,915 cf, Atten= 1%, Lag= 1.5 min
 Primary = 0.04 cfs @ 12.17 hrs, Volume= 1,915 cf
 Routed to Reach BMP9_O : BMP-9 OVERFLOW

Routing by Stor-Ind method, Time Span= 0.00-72.00 hrs, dt= 0.05 hrs
 Peak Elev= 5.39' @ 12.17 hrs Surf.Area= 190 sf Storage= 22 cf

Plug-Flow detention time= 13.4 min calculated for 1,915 cf (99% of inflow)
 Center-of-Mass det. time= 8.8 min (993.3 - 984.5)

Volume	Invert	Avail.Storage	Storage Description
#1	5.00'	114 cf	Custom Stage Data (Prismatic) Listed below (Recalc) 380 cf Overall x 30.0% Voids

Elevation (feet)	Surf.Area (sq-ft)	Inc.Store (cubic-feet)	Cum.Store (cubic-feet)
5.00	190	0	0
7.00	190	380	380

Device	Routing	Invert	Outlet Devices
#1	Primary	5.25'	4.0" Vert. Orifice/Grate C= 0.600 Limited to weir flow at low heads

Primary OutFlow Max=0.04 cfs @ 12.17 hrs HW=5.39' (Free Discharge)

↳1=Orifice/Grate (Orifice Controls 0.04 cfs @ 1.26 fps)

14850_Proposed-Drainage-Areas_220609

NOAA 24-hr C NOAA 2-yr Rainfall=3.40"

Prepared by {enter your company name here}

Printed 6/16/2022

HydroCAD® 10.10-7a s/n 00546 © 2021 HydroCAD Software Solutions LLC

Page 111

Summary for Pond 14P: BB2A-Stone

Inflow = 0.03 cfs @ 12.26 hrs, Volume= 689 cf
 Outflow = 0.03 cfs @ 12.31 hrs, Volume= 689 cf, Atten= 0%, Lag= 3.0 min
 Primary = 0.03 cfs @ 12.31 hrs, Volume= 689 cf
 Routed to Reach DP-1 : French Rodney Blvd Outfall

Routing by Stor-Ind method, Time Span= 0.00-72.00 hrs, dt= 0.05 hrs
 Peak Elev= 5.60' @ 12.31 hrs Surf.Area= 180 sf Storage= 6 cf

Plug-Flow detention time= 5.3 min calculated for 689 cf (100% of inflow)
 Center-of-Mass det. time= 5.4 min (863.4 - 858.1)

Volume	Invert	Avail.Storage	Storage Description
#1	5.50'	108 cf	Custom Stage Data (Prismatic) Listed below (Recalc) 360 cf Overall x 30.0% Voids

Elevation (feet)	Surf.Area (sq-ft)	Inc.Store (cubic-feet)	Cum.Store (cubic-feet)
5.50	180	0	0
7.50	180	360	360

Device	Routing	Invert	Outlet Devices
#1	Primary	5.50'	4.0" Vert. Orifice/Grate C= 0.600 Limited to weir flow at low heads

Primary OutFlow Max=0.03 cfs @ 12.31 hrs HW=5.60' (Free Discharge)
 ↳1=Orifice/Grate (Orifice Controls 0.03 cfs @ 1.10 fps)

14850_Proposed-Drainage-Areas_220609

NOAA 24-hr C NOAA 2-yr Rainfall=3.40"

Prepared by {enter your company name here}

Printed 6/16/2022

HydroCAD® 10.10-7a s/n 00546 © 2021 HydroCAD Software Solutions LLC

Page 112

Summary for Pond DMH1: DIVERSION MANHOLE - SEYMOUR ST

[57] Hint: Peaked at 9.61' (Flood elevation advised)

Inflow Area = 19,582 sf, 58.17% Impervious, Inflow Depth = 2.18" for NOAA 2-yr event
 Inflow = 1.23 cfs @ 12.13 hrs, Volume= 3,554 cf
 Outflow = 1.23 cfs @ 12.13 hrs, Volume= 3,554 cf, Atten= 0%, Lag= 0.0 min
 Primary = 0.57 cfs @ 12.13 hrs, Volume= 2,974 cf
 Routed to Pond INF-1 : INFILTRATION SYSTEM #1
 Secondary = 0.66 cfs @ 12.13 hrs, Volume= 580 cf
 Routed to Reach DP-1 : French Rodney Blvd Outfall

Routing by Stor-Ind method, Time Span= 0.00-72.00 hrs, dt= 0.05 hrs
 Peak Elev= 9.61' @ 12.13 hrs

Device	Routing	Invert	Outlet Devices
#1	Primary	9.00'	6.0" Vert. WATER QUALITY STORM DIVERSION C= 0.600 Limited to weir flow at low heads
#2	Secondary	9.20'	12.0" Vert. LARGE STORM OVEFLOW C= 0.600 Limited to weir flow at low heads

Primary OutFlow Max=0.56 cfs @ 12.13 hrs HW=9.60' (Free Discharge)
 ↳1=WATER QUALITY STORM DIVERSION(Orifice Controls 0.56 cfs @ 2.83 fps)

Secondary OutFlow Max=0.62 cfs @ 12.13 hrs HW=9.60' (Free Discharge)
 ↳2=LARGE STORM OVEFLOW (Orifice Controls 0.62 cfs @ 2.14 fps)

14850_Proposed-Drainage-Areas_220609

NOAA 24-hr C NOAA 2-yr Rainfall=3.40"

Prepared by {enter your company name here}

Printed 6/16/2022

HydroCAD® 10.10-7a s/n 00546 © 2021 HydroCAD Software Solutions LLC

Page 113

Summary for Pond DMH2: DIVERSION MANHOLE - HUDSON STREET

[57] Hint: Peaked at 14.56' (Flood elevation advised)

Inflow Area = 143,309 sf, 49.69% Impervious, Inflow Depth = 2.01" for NOAA 2-yr event
 Inflow = 8.38 cfs @ 12.13 hrs, Volume= 24,005 cf
 Outflow = 8.38 cfs @ 12.13 hrs, Volume= 24,005 cf, Atten= 0%, Lag= 0.0 min
 Primary = 1.83 cfs @ 12.13 hrs, Volume= 15,418 cf
 Routed to Pond INF-2 : INFILTRATION SYSTEM #2
 Secondary = 6.55 cfs @ 12.13 hrs, Volume= 8,588 cf
 Routed to Reach B : PARKING LOT B OVERFLOW

Routing by Stor-Ind method, Time Span= 0.00-72.00 hrs, dt= 0.05 hrs
 Peak Elev= 14.56' @ 12.13 hrs

Device	Routing	Invert	Outlet Devices
#1	Primary	10.60'	6.0" Vert. WATER QUALITY STORM DIVERSION C= 0.600 Limited to weir flow at low heads
#2	Secondary	11.10'	12.0" Vert. LARGE STORM OVERFLOW C= 0.600 Limited to weir flow at low heads

Primary OutFlow Max=1.77 cfs @ 12.13 hrs HW=14.35' (Free Discharge)↳ **1=WATER QUALITY STORM DIVERSION** (Orifice Controls 1.77 cfs @ 9.01 fps)**Secondary OutFlow** Max=6.27 cfs @ 12.13 hrs HW=14.35' (Free Discharge)↳ **2=LARGE STORM OVERFLOW** (Orifice Controls 6.27 cfs @ 7.99 fps)**14850_Proposed-Drainage-Areas_220609**

NOAA 24-hr C NOAA 2-yr Rainfall=3.40"

Prepared by {enter your company name here}

Printed 6/16/2022

HydroCAD® 10.10-7a s/n 00546 © 2021 HydroCAD Software Solutions LLC

Page 114

Summary for Pond DMH3: DIVERSION MANHOLE - PORTLAND ST

[57] Hint: Peaked at 11.54' (Flood elevation advised)

Inflow Area = 19,743 sf, 50.83% Impervious, Inflow Depth = 2.01" for NOAA 2-yr event
 Inflow = 1.15 cfs @ 12.13 hrs, Volume= 3,307 cf
 Outflow = 1.15 cfs @ 12.13 hrs, Volume= 3,307 cf, Atten= 0%, Lag= 0.0 min
 Primary = 0.75 cfs @ 12.13 hrs, Volume= 2,972 cf
 Routed to Pond INF3 : INFILTRATION SYSTEM #1
 Secondary = 0.40 cfs @ 12.13 hrs, Volume= 335 cf
 Routed to Reach P ST : PORTLAND STREET DRAINAGE

Routing by Stor-Ind method, Time Span= 0.00-72.00 hrs, dt= 0.05 hrs
 Peak Elev= 11.54' @ 12.13 hrs

Device	Routing	Invert	Outlet Devices
#1	Primary	11.00'	8.0" Vert. WATER QUALITY DIVERSION C= 0.600 Limited to weir flow at low heads
#2	Secondary	11.20'	10.0" Vert. LARGE STORM OVERFLOW C= 0.600 Limited to weir flow at low heads

Primary OutFlow Max=0.73 cfs @ 12.13 hrs HW=11.52' (Free Discharge)↳ **1=WATER QUALITY DIVERSION** (Orifice Controls 0.73 cfs @ 2.47 fps)**Secondary OutFlow** Max=0.38 cfs @ 12.13 hrs HW=11.52' (Free Discharge)↳ **2=LARGE STORM OVERFLOW** (Orifice Controls 0.38 cfs @ 1.94 fps)

14850_Proposed-Drainage-Areas_220609

NOAA 24-hr C NOAA 2-yr Rainfall=3.40"

Prepared by {enter your company name here}

Printed 6/16/2022

HydroCAD® 10.10-7a s/n 00546 © 2021 HydroCAD Software Solutions LLC

Page 115

Summary for Pond INF-1: INFILTRATION SYSTEM #1

[79] Warning: Submerged Pond DMH1 Primary device # 1 by 0.01'

Inflow Area = 19,582 sf, 58.17% Impervious, Inflow Depth = 1.82" for NOAA 2-yr event
 Inflow = 0.57 cfs @ 12.13 hrs, Volume= 2,974 cf
 Outflow = 0.07 cfs @ 13.69 hrs, Volume= 2,974 cf, Atten= 88%, Lag= 93.8 min
 Discarded = 0.07 cfs @ 13.69 hrs, Volume= 2,974 cf
 Primary = 0.00 cfs @ 0.00 hrs, Volume= 0 cf
 Routed to Reach DP-1 : French Rodney Blvd Outfall

Routing by Stor-Ind method, Time Span= 0.00-72.00 hrs, dt= 0.05 hrs
 Peak Elev= 9.01' @ 13.69 hrs Surf.Area= 1,772 sf Storage= 1,232 cf

Plug-Flow detention time= 185.7 min calculated for 2,972 cf (100% of inflow)
 Center-of-Mass det. time= 185.6 min (1,018.3 - 832.7)

Volume	Invert	Avail.Storage	Storage Description
#1A	7.80'	1,091 cf	21.50'W x 81.52'L x 2.33'H Field A 4,090 cf Overall - 973 cf Embedded = 3,117 cf x 35.0% Voids
#2A	8.30'	973 cf	ADS_StormTech SC-310 +Cap x 66 Inside #1 Effective Size= 28.9"W x 16.0"H => 2.07 sf x 7.12'L = 14.7 cf Overall Size= 34.0"W x 16.0"H x 7.56'L with 0.44' Overlap 66 Chambers in 6 Rows
#3	7.80'	137 cf	5.00'D x 7.00'H Vertical Cone/Cylinder
		2,201 cf	Total Available Storage

Storage Group A created with Chamber Wizard

Device	Routing	Invert	Outlet Devices
#1	Discarded	7.80'	1.020 in/hr Exfiltration over Surface area Conductivity to Groundwater Elevation = 5.80'
#2	Primary	8.10'	10.0" Round Culvert L= 10.0' CPP, square edge headwall, Ke= 0.500 Inlet / Outlet Invert= 8.10' / 8.00' S= 0.0100 '/ Cc= 0.900 n= 0.012 Corrugated PP, smooth interior, Flow Area= 0.55 sf
#3	Device 2	9.40'	5.0' long Sharp-Crested Rectangular Weir 2 End Contraction(s)

Discarded OutFlow Max=0.07 cfs @ 13.69 hrs HW=9.01' (Free Discharge)
 1=Exfiltration (Controls 0.07 cfs)

Primary OutFlow Max=0.00 cfs @ 0.00 hrs HW=7.80' (Free Discharge)
 2=Culvert (Controls 0.00 cfs)

3=Sharp-Crested Rectangular Weir(Controls 0.00 cfs)

14850_Proposed-Drainage-Areas_220609

NOAA 24-hr C NOAA 2-yr Rainfall=3.40"

Prepared by {enter your company name here}

Printed 6/16/2022

HydroCAD® 10.10-7a s/n 00546 © 2021 HydroCAD Software Solutions LLC

Page 116

Pond INF-1: INFILTRATION SYSTEM #1 - Chamber Wizard Field A

Chamber Model = ADS_StormTechSC-310 +Cap (ADS StormTech®SC-310 with cap length)

Effective Size= 28.9"W x 16.0"H => 2.07 sf x 7.12'L = 14.7 cf

Overall Size= 34.0"W x 16.0"H x 7.56'L with 0.44' Overlap

34.0" Wide + 6.0" Spacing = 40.0" C-C Row Spacing

11 Chambers/Row x 7.12' Long +0.60' Cap Length x 2 = 79.52' Row Length +12.0" End Stone x 2 = 81.52' Base Length

6 Rows x 34.0" Wide + 6.0" Spacing x 5 + 12.0" Side Stone x 2 = 21.50' Base Width

6.0" Stone Base + 16.0" Chamber Height + 6.0" Stone Cover = 2.33' Field Height

66 Chambers x 14.7 cf = 973.0 cf Chamber Storage

4,089.6 cf Field - 973.0 cf Chambers = 3,116.6 cf Stone x 35.0% Voids = 1,090.8 cf Stone Storage

Chamber Storage + Stone Storage = 2,063.8 cf = 0.047 af

Overall Storage Efficiency = 50.5%

Overall System Size = 81.52' x 21.50' x 2.33'

66 Chambers
 151.5 cy Field
 115.4 cy Stone

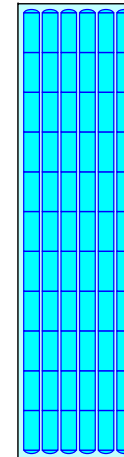

14850_Proposed-Drainage-Areas_220609

NOAA 24-hr C NOAA 2-yr Rainfall=3.40"

Prepared by {enter your company name here}

Printed 6/16/2022

HydroCAD® 10.10-7a s/n 00546 © 2021 HydroCAD Software Solutions LLC

Page 117

Summary for Pond INF-2: INFILTRATION SYSTEM #2

Inflow Area = 143,309 sf, 49.69% Impervious, Inflow Depth = 1.29" for NOAA 2-yr event
 Inflow = 1.83 cfs @ 12.13 hrs, Volume= 15,418 cf
 Outflow = 1.53 cfs @ 12.20 hrs, Volume= 15,418 cf, Atten= 16%, Lag= 3.8 min
 Discarded = 0.11 cfs @ 12.20 hrs, Volume= 8,554 cf
 Primary = 1.42 cfs @ 12.20 hrs, Volume= 6,864 cf
 Routed to Reach B : PARKING LOT B OVERFLOW

Routing by Stor-Ind method, Time Span= 0.00-72.00 hrs, dt= 0.05 hrs
 Peak Elev= 9.70' @ 12.20 hrs Surf.Area= 2,268 sf Storage= 3,280 cf

Plug-Flow detention time= 204.5 min calculated for 15,407 cf (100% of inflow)
 Center-of-Mass det. time= 204.8 min (1,079.0 - 874.2)

Volume	Invert	Avail.Storage	Storage Description
#1A	7.50'	1,790 cf	25.25'W x 89.06'L x 3.50'H Field A 7,870 cf Overall - 2,756 cf Embedded = 5,114 cf x 35.0% Voids
#2A	8.00'	2,756 cf	ADS_StormTech SC-740 +Cap x 60 Inside #1 Effective Size= 44.6"W x 30.0"H => 6.45 sf x 7.12'L = 45.9 cf Overall Size= 51.0"W x 30.0"H x 7.56'L with 0.44' Overlap 60 Chambers in 5 Rows
#3	7.50'	137 cf	5.00'D x 7.00'H Vertical Cone/Cylinder
		4,684 cf	Total Available Storage

Storage Group A created with Chamber Wizard

Device	Routing	Invert	Outlet Devices
#1	Discarded	7.50'	1.020 in/hr Exfiltration over Surface area Conductivity to Groundwater Elevation = 5.50'
#2	Primary	8.00'	10.0" Round Culvert L= 10.0' CPP, square edge headwall, Ke= 0.500 Inlet / Outlet Invert= 8.00' / 7.90' S= 0.0100 '/ Cc= 0.900 n= 0.012 Corrugated PP, smooth interior, Flow Area= 0.55 sf
#3	Device 2	9.50'	5.0' long Sharp-Crested Rectangular Weir 2 End Contraction(s)

Discarded OutFlow Max=0.11 cfs @ 12.20 hrs HW=9.69' (Free Discharge)
 ↳1=Exfiltration (Controls 0.11 cfs)

Primary OutFlow Max=1.39 cfs @ 12.20 hrs HW=9.69' (Free Discharge)
 ↳2=Culvert (Passes 1.39 cfs of 2.97 cfs potential flow)
 ↳3=Sharp-Crested Rectangular Weir(Weir Controls 1.39 cfs @ 1.44 fps)

14850_Proposed-Drainage-Areas_220609

NOAA 24-hr C NOAA 2-yr Rainfall=3.40"

Prepared by {enter your company name here}

Printed 6/16/2022

HydroCAD® 10.10-7a s/n 00546 © 2021 HydroCAD Software Solutions LLC

Page 118

Pond INF-2: INFILTRATION SYSTEM #2 - Chamber Wizard Field A

Chamber Model = ADS_StormTechSC-740 +Cap (ADS StormTech®SC-740 with cap length)

Effective Size= 44.6"W x 30.0"H => 6.45 sf x 7.12'L = 45.9 cf

Overall Size= 51.0"W x 30.0"H x 7.56'L with 0.44' Overlap

51.0" Wide + 6.0" Spacing = 57.0" C-C Row Spacing

12 Chambers/Row x 7.12' Long +0.81' Cap Length x 2 = 87.06' Row Length +12.0" End Stone x 2 = 89.06' Base Length

5 Rows x 51.0" Wide + 6.0" Spacing x 4 + 12.0" Side Stone x 2 = 25.25' Base Width

6.0" Stone Base + 30.0" Chamber Height + 6.0" Stone Cover = 3.50' Field Height

60 Chambers x 45.9 cf = 2,756.4 cf Chamber Storage

7,870.4 cf Field - 2,756.4 cf Chambers = 5,114.0 cf Stone x 35.0% Voids = 1,789.9 cf Stone Storage

Chamber Storage + Stone Storage = 4,546.3 cf = 0.104 af

Overall Storage Efficiency = 57.8%

Overall System Size = 89.06' x 25.25' x 3.50'

60 Chambers
 291.5 cy Field
 189.4 cy Stone

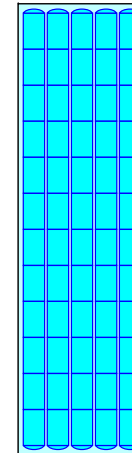

14850_Proposed-Drainage-Areas_220609

NOAA 24-hr C NOAA 2-yr Rainfall=3.40"

Prepared by {enter your company name here}

Printed 6/16/2022

HydroCAD@ 10.10-7a s/n 00546 © 2021 HydroCAD Software Solutions LLC

Page 119

Summary for Pond INF3: INFILTRATION SYSTEM #1

Inflow Area = 19,743 sf, 50.83% Impervious, Inflow Depth = 1.81" for NOAA 2-yr event
 Inflow = 0.75 cfs @ 12.13 hrs, Volume= 2,972 cf
 Outflow = 0.38 cfs @ 12.32 hrs, Volume= 2,972 cf, Atten= 50%, Lag= 11.1 min
 Discarded = 0.05 cfs @ 12.32 hrs, Volume= 2,339 cf
 Primary = 0.33 cfs @ 12.32 hrs, Volume= 633 cf
 Routed to Reach P ST : PORTLAND STREET DRAINAGE

Routing by Stor-Ind method, Time Span= 0.00-72.00 hrs, dt= 0.05 hrs
 Peak Elev= 9.57' @ 12.32 hrs Surf.Area= 1,113 sf Storage= 944 cf

Plug-Flow detention time= 182.2 min calculated for 2,970 cf (100% of inflow)
 Center-of-Mass det. time= 182.2 min (1,016.0 - 833.8)

Volume	Invert	Avail.Storage	Storage Description
#1A	8.10'	686 cf	18.17'W x 60.16'L x 2.33'H Field A 2,550 cf Overall - 590 cf Embedded = 1,960 cf x 35.0% Voids
#2A	8.60'	590 cf	ADS_StormTech SC-310 +Cap x 40 Inside #1 Effective Size= 28.9"W x 16.0"H => 2.07 sf x 7.12'L = 14.7 cf Overall Size= 34.0"W x 16.0"H x 7.56'L with 0.44' Overlap 40 Chambers in 5 Rows
#3	8.10'	137 cf	5.00'D x 7.00'H Vertical Cone/Cylinder
		1,413 cf	Total Available Storage

Storage Group A created with Chamber Wizard

Device	Routing	Invert	Outlet Devices
#1	Discarded	8.10'	1.020 in/hr Exfiltration over Surface area Conductivity to Groundwater Elevation = 6.10'
#2	Primary	8.40'	10.0" Round Culvert L= 10.0' CPP, square edge headwall, Ke= 0.500 Inlet / Outlet Invert= 8.40' / 8.30' S= 0.0100 '/ Cc= 0.900 n= 0.012 Corrugated PP, smooth interior, Flow Area= 0.55 sf
#3	Device 2	9.50'	5.0' long Sharp-Crested Rectangular Weir 2 End Contraction(s)

Discarded OutFlow Max=0.05 cfs @ 12.32 hrs HW=9.57' (Free Discharge)
 ↳1=Exfiltration (Controls 0.05 cfs)

Primary OutFlow Max=0.31 cfs @ 12.32 hrs HW=9.57' (Free Discharge)
 ↳2=Culvert (Passes 0.31 cfs of 2.13 cfs potential flow)
 ↳3=Sharp-Crested Rectangular Weir(Weir Controls 0.31 cfs @ 0.87 fps)

14850_Proposed-Drainage-Areas_220609

NOAA 24-hr C NOAA 2-yr Rainfall=3.40"

Prepared by {enter your company name here}

Printed 6/16/2022

HydroCAD@ 10.10-7a s/n 00546 © 2021 HydroCAD Software Solutions LLC

Page 120

Pond INF3: INFILTRATION SYSTEM #1 - Chamber Wizard Field A

Chamber Model = ADS_StormTechSC-310 +Cap (ADS StormTech@SC-310 with cap length)

Effective Size= 28.9"W x 16.0"H => 2.07 sf x 7.12'L = 14.7 cf

Overall Size= 34.0"W x 16.0"H x 7.56'L with 0.44' Overlap

34.0" Wide + 6.0" Spacing = 40.0" C-C Row Spacing

8 Chambers/Row x 7.12' Long +0.60' Cap Length x 2 = 58.16' Row Length +12.0" End Stone x 2 = 60.16' Base Length

5 Rows x 34.0" Wide + 6.0" Spacing x 4 + 12.0" Side Stone x 2 = 18.17' Base Width

6.0" Stone Base + 16.0" Chamber Height + 6.0" Stone Cover = 2.33' Field Height

40 Chambers x 14.7 cf = 589.7 cf Chamber Storage

2,550.1 cf Field - 589.7 cf Chambers = 1,960.4 cf Stone x 35.0% Voids = 686.2 cf Stone Storage

Chamber Storage + Stone Storage = 1,275.8 cf = 0.029 af

Overall Storage Efficiency = 50.0%

Overall System Size = 60.16' x 18.17' x 2.33'

40 Chambers
 94.4 cy Field
 72.6 cy Stone

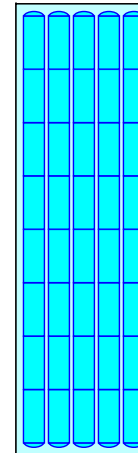

14850_Proposed-Drainage-Areas_220609

NOAA 24-hr C NOAA 25-yr Rainfall=6.04"

Prepared by {enter your company name here}

Printed 6/16/2022

HydroCAD® 10.10-7a s/n 00546 © 2021 HydroCAD Software Solutions LLC

Page 121

Time span=0.00-72.00 hrs, dt=0.05 hrs, 1441 points
 Runoff by SCS TR-20 method, UH=SCS, Weighted-CN
 Reach routing by Stor-Ind+Trans method - Pond routing by Stor-Ind method

Pond 1-P: BB 1 Peak Elev=10.18' Storage=1,085 cf Inflow=4.84 cfs 14,390 cf
 Discarded=0.05 cfs 2,687 cf Primary=2.39 cfs 1,961 cf Secondary=2.27 cfs 9,742 cf Outflow=4.72 cfs 14,390 cf

Pond 2a-P: BB 2a Peak Elev=9.39' Storage=267 cf Inflow=0.44 cfs 1,446 cf
 Primary=0.40 cfs 468 cf Secondary=0.03 cfs 978 cf Outflow=0.43 cfs 1,446 cf

Pond 2b-P: BB 2b Peak Elev=8.48' Storage=245 cf Inflow=2.97 cfs 9,352 cf
 Primary=2.67 cfs 9,352 cf Secondary=0.00 cfs 0 cf Outflow=2.67 cfs 9,352 cf

Pond 3A-P: BB 3A Peak Elev=11.10' Storage=472 cf Inflow=1.42 cfs 4,271 cf
 Discarded=0.03 cfs 1,429 cf Primary=1.34 cfs 2,842 cf Outflow=1.36 cfs 4,271 cf

Pond 3B-P: BB 3B Peak Elev=12.90' Storage=260 cf Inflow=0.63 cfs 1,978 cf
 Discarded=0.02 cfs 880 cf Primary=0.60 cfs 1,098 cf Outflow=0.62 cfs 1,978 cf

Pond 4A-P: BB 4A - POND Peak Elev=10.07' Storage=239 cf Inflow=0.68 cfs 2,200 cf
 Primary=0.63 cfs 937 cf Secondary=0.04 cfs 1,263 cf Outflow=0.66 cfs 2,200 cf

Pond 4A-S: BB4A-Stone Peak Elev=7.13' Storage=26 cf Inflow=0.04 cfs 1,263 cf
 Outflow=0.04 cfs 1,246 cf

Pond 4B-P: BB 4B - POND Peak Elev=11.04' Storage=136 cf Inflow=0.43 cfs 1,385 cf
 Primary=0.40 cfs 597 cf Secondary=0.02 cfs 787 cf Outflow=0.42 cfs 1,385 cf

Pond 4B-S: BB 4A-Stone Peak Elev=7.85' Storage=15 cf Inflow=0.02 cfs 787 cf
 Outflow=0.02 cfs 776 cf

Pond 5A-P: BB 5A - POND Peak Elev=9.52' Storage=431 cf Inflow=0.42 cfs 1,308 cf
 Primary=0.07 cfs 72 cf Secondary=0.05 cfs 1,236 cf Outflow=0.12 cfs 1,308 cf

Pond 5A-PS: BB 5A-Stone Peak Elev=5.94' Storage=57 cf Inflow=0.05 cfs 1,236 cf
 Outflow=0.05 cfs 1,200 cf

Pond 5B-P: BB 5B - POND Peak Elev=9.08' Storage=711 cf Inflow=4.69 cfs 14,471 cf
 Primary=2.32 cfs 1,506 cf Secondary=0.09 cfs 4,416 cf Tertiary=2.36 cfs 8,549 cf Outflow=4.78 cfs 14,471 cf

Pond 5B-PS: BB 5B-Stone Peak Elev=5.46' Storage=96 cf Inflow=0.09 cfs 4,416 cf
 Outflow=0.09 cfs 4,364 cf

Pond 6A-P: BB 6A - POND Peak Elev=11.03' Storage=443 cf Inflow=1.85 cfs 5,479 cf
 Primary=1.78 cfs 3,305 cf Secondary=0.05 cfs 2,174 cf Outflow=1.83 cfs 5,479 cf

Pond 6A-PS: BB 6A - STONE Peak Elev=7.39' Storage=34 cf Inflow=0.05 cfs 2,174 cf
 Outflow=0.05 cfs 2,152 cf

Pond 6B-P: BB 6B Peak Elev=12.10' Storage=393 cf Inflow=0.90 cfs 2,826 cf
 Discarded=0.02 cfs 1,170 cf Primary=0.84 cfs 1,657 cf Outflow=0.86 cfs 2,826 cf

14850_Proposed-Drainage-Areas_220609

NOAA 24-hr C NOAA 25-yr Rainfall=6.04"

Prepared by {enter your company name here}

Printed 6/16/2022

HydroCAD® 10.10-7a s/n 00546 © 2021 HydroCAD Software Solutions LLC

Page 122

Pond 7A-P: BB 7A PONDING Peak Elev=9.99' Storage=153 cf Inflow=0.45 cfs 1,438 cf
 Primary=0.42 cfs 638 cf Secondary=0.02 cfs 800 cf Outflow=0.44 cfs 1,438 cf

Pond 7A-S: BB 7A - STONE Peak Elev=5.19' Storage=4 cf Inflow=0.02 cfs 800 cf
 Outflow=0.02 cfs 800 cf

Pond 7B-P: BB 7B PONDING Peak Elev=10.72' Storage=282 cf Inflow=0.70 cfs 2,245 cf
 Primary=0.65 cfs 940 cf Secondary=0.03 cfs 1,305 cf Outflow=0.68 cfs 2,245 cf

Pond 7B-S: BB 7B - STONE Peak Elev=7.62' Storage=17 cf Inflow=0.03 cfs 1,305 cf
 Outflow=0.03 cfs 1,294 cf

Pond 8a-P: BB 8A PONDING Peak Elev=9.10' Storage=295 cf Inflow=0.55 cfs 1,731 cf
 Primary=0.48 cfs 547 cf Secondary=0.04 cfs 1,184 cf Outflow=0.52 cfs 1,731 cf

Pond 8a-s: BB 8A - STONE Peak Elev=5.63' Storage=30 cf Inflow=0.04 cfs 1,184 cf
 Outflow=0.04 cfs 1,166 cf

Pond 8B-P: BB 8B-PONDING Peak Elev=9.73' Storage=262 cf Inflow=0.79 cfs 2,543 cf
 Primary=0.74 cfs 1,102 cf Secondary=0.04 cfs 1,441 cf Outflow=0.78 cfs 2,543 cf

Pond 8B-S: BB 8B-Stone Peak Elev=6.33' Storage=39 cf Inflow=0.04 cfs 1,441 cf
 Outflow=0.04 cfs 1,414 cf

Pond 9-P: BB9 - POND Peak Elev=8.99' Storage=476 cf Inflow=4.05 cfs 12,623 cf
 Primary=1.24 cfs 542 cf Secondary=0.05 cfs 2,332 cf Tertiary=2.68 cfs 9,749 cf Outflow=3.97 cfs 12,623 cf

Pond 9-PS: BB9 - STONE Peak Elev=5.40' Storage=23 cf Inflow=0.05 cfs 2,332 cf
 Outflow=0.05 cfs 2,318 cf

Pond 14P: BB2A-Stone Peak Elev=5.61' Storage=6 cf Inflow=0.03 cfs 978 cf
 Outflow=0.03 cfs 978 cf

Pond DMH1: DIVERSION MANHOLE - SEYMOUR ST Peak Elev=9.92' Inflow=2.53 cfs 7,612 cf
 Primary=0.78 cfs 5,625 cf Secondary=1.75 cfs 1,987 cf Outflow=2.53 cfs 7,612 cf

Pond DMH2: DIVERSION MANHOLE - HUDSON STREET Peak Elev=25.58' Inflow=17.88 cfs 53,113 cf
 Primary=3.65 cfs 28,364 cf Secondary=14.23 cfs 24,749 cf Outflow=17.88 cfs 53,113 cf

Pond DMH3: DIVERSION MANHOLE - PORTLANDST Peak Elev=11.85' Inflow=2.46 cfs 7,317 cf
 Primary=1.21 cfs 6,020 cf Secondary=1.25 cfs 1,297 cf Outflow=2.46 cfs 7,317 cf

Pond INF-1: INFILTRATIONSYSTEM#1 Peak Elev=9.48' Storage=1,689 cf Inflow=0.78 cfs 5,625 cf
 Discarded=0.08 cfs 4,624 cf Primary=0.37 cfs 1,001 cf Outflow=0.45 cfs 5,625 cf

Pond INF-2: INFILTRATIONSYSTEM#2 Peak Elev=9.87' Storage=3,518 cf Inflow=3.65 cfs 28,364 cf
 Discarded=0.12 cfs 9,579 cf Primary=3.18 cfs 18,785 cf Outflow=3.30 cfs 28,364 cf

Pond INF3: INFILTRATIONSYSTEM#1 Peak Elev=9.67' Storage=1,000 cf Inflow=1.21 cfs 6,020 cf
 Discarded=0.05 cfs 3,178 cf Primary=1.15 cfs 2,842 cf Outflow=1.20 cfs 6,020 cf

14850_Proposed-Drainage-Areas_220609

NOAA 24-hr C NOAA 25-yr Rainfall=6.04"

Prepared by {enter your company name here}

Printed 6/16/2022

HydroCAD® 10.10-7a s/n 00546 © 2021 HydroCAD Software Solutions LLC

Page 123

Summary for Pond 1-P: BB 1

Inflow Area = 38,826 sf, 51.66% Impervious, Inflow Depth = 4.45" for NOAA 25-yr event
 Inflow = 4.84 cfs @ 12.13 hrs, Volume= 14,390 cf
 Outflow = 4.72 cfs @ 12.15 hrs, Volume= 14,390 cf, Atten= 3%, Lag= 1.1 min
 Discarded = 0.05 cfs @ 12.15 hrs, Volume= 2,687 cf
 Primary = 2.39 cfs @ 12.15 hrs, Volume= 1,961 cf
 Routed to Reach 17R : Rodney French Pipe
 Secondary = 2.27 cfs @ 12.15 hrs, Volume= 9,742 cf
 Routed to Reach 15R : ISOLATOR ROW 1

Routing by Stor-Ind method, Time Span= 0.00-72.00 hrs, dt= 0.05 hrs
 Peak Elev= 10.18' @ 12.15 hrs Surf.Area= 1,807 sf Storage= 1,085 cf

Plug-Flow detention time= 44.4 min calculated for 14,380 cf (100% of inflow)
 Center-of-Mass det. time= 44.6 min (844.8 - 800.1)

Volume	Invert	Avail.Storage	Storage Description
#1	9.20'	1,114 cf	Custom Stage Data (Prismatic) Listed below (Recalc)

Elevation (feet)	Surf.Area (sq-ft)	Inc.Store (cubic-feet)	Cum.Store (cubic-feet)
9.20	490	0	0
9.50	800	194	194
10.20	1,830	920	1,114

Device	Routing	Invert	Outlet Devices
#1	Primary	8.00'	12.0" Round Culvert L= 10.0' CPP, square edge headwall, Ke= 0.500 Inlet / Outlet Invert= 8.00' / 7.90' S= 0.0100 '/ Cc= 0.900 n= 0.013, Flow Area= 0.79 sf
#2	Discarded	9.20'	1.020 in/hr Exfiltration over Surface area Conductivity to Groundwater Elevation = 6.00'
#3	Device 1	10.00'	24inch-Dome Grate Capacity X 2.00
#4	Secondary	9.83'	15inch-Dome Grate Capacity

Discarded OutFlow Max=0.05 cfs @ 12.15 hrs HW=10.18' (Free Discharge)
 ↳2=Exfiltration (Controls 0.05 cfs)

Primary OutFlow Max=2.36 cfs @ 12.15 hrs HW=10.18' (Free Discharge)
 ↳1=Culvert (Passes 2.36 cfs of 4.90 cfs potential flow)
 ↳3=24inch-Dome Grate Capacity (Custom Controls 2.36 cfs)

Secondary OutFlow Max=2.27 cfs @ 12.15 hrs HW=10.18' (Free Discharge)
 ↳4=15inch-Dome Grate Capacity (Custom Controls 2.27 cfs)

14850_Proposed-Drainage-Areas_220609

NOAA 24-hr C NOAA 25-yr Rainfall=6.04"

Prepared by {enter your company name here}

Printed 6/16/2022

HydroCAD® 10.10-7a s/n 00546 © 2021 HydroCAD Software Solutions LLC

Page 124

Summary for Pond 2a-P: BB 2a

Inflow Area = 3,116 sf, 92.62% Impervious, Inflow Depth = 5.57" for NOAA 25-yr event
 Inflow = 0.44 cfs @ 12.13 hrs, Volume= 1,446 cf
 Outflow = 0.43 cfs @ 12.14 hrs, Volume= 1,446 cf, Atten= 3%, Lag= 1.1 min
 Primary = 0.40 cfs @ 12.14 hrs, Volume= 468 cf
 Routed to Reach DP-1 : French Rodney Blvd Outfall
 Secondary = 0.03 cfs @ 12.14 hrs, Volume= 978 cf
 Routed to Pond 14P : BB2A-Stone

Routing by Stor-Ind method, Time Span= 0.00-72.00 hrs, dt= 0.05 hrs
 Peak Elev= 9.39' @ 12.14 hrs Surf.Area= 420 sf Storage= 267 cf

Plug-Flow detention time= 57.6 min calculated for 1,445 cf (100% of inflow)
 Center-of-Mass det. time= 57.6 min (816.9 - 759.3)

Volume	Invert	Avail.Storage	Storage Description
#1	8.50'	462 cf	Custom Stage Data (Prismatic) Listed below (Recalc)

Elevation (feet)	Surf.Area (sq-ft)	Inc.Store (cubic-feet)	Cum.Store (cubic-feet)
8.50	180	0	0
9.80	530	462	462

Device	Routing	Invert	Outlet Devices
#1	Primary	7.80'	10.0" Round Culvert L= 10.0' CPP, square edge headwall, Ke= 0.500 Inlet / Outlet Invert= 7.80' / 7.70' S= 0.0100 '/ Cc= 0.900 n= 0.013, Flow Area= 0.55 sf
#2	Device 1	9.30'	24inch-Dome Grate Capacity
#3	Secondary	8.50'	2.410 in/hr Exfiltration over Surface area Conductivity to Groundwater Elevation = 4.60'

Primary OutFlow Max=0.40 cfs @ 12.14 hrs HW=9.39' (Free Discharge)
 ↳1=Culvert (Passes 0.40 cfs of 2.84 cfs potential flow)
 ↳2=24inch-Dome Grate Capacity (Custom Controls 0.40 cfs)

Secondary OutFlow Max=0.03 cfs @ 12.14 hrs HW=9.39' (Free Discharge)
 ↳3=Exfiltration (Controls 0.03 cfs)

14850_Proposed-Drainage-Areas_220609

NOAA 24-hr C NOAA 25-yr Rainfall=6.04"

Prepared by {enter your company name here}

Printed 6/16/2022

HydroCAD® 10.10-7a s/n 00546 © 2021 HydroCAD Software Solutions LLC

Page 125

Summary for Pond 2b-P: BB 2b

Inflow Area = 21,490 sf, 80.50% Impervious, Inflow Depth = 5.22" for NOAA 25-yr event
 Inflow = 2.97 cfs @ 12.13 hrs, Volume= 9,352 cf
 Outflow = 2.67 cfs @ 12.16 hrs, Volume= 9,352 cf, Atten= 10%, Lag= 1.9 min
 Primary = 2.67 cfs @ 12.16 hrs, Volume= 9,352 cf
 Routed to Reach 15R : ISOLATOR ROW 1
 Secondary = 0.00 cfs @ 0.00 hrs, Volume= 0 cf
 Routed to Reach DP-1 : French Rodney Blvd Outfall

Routing by Stor-Ind method, Time Span= 0.00-72.00 hrs, dt= 0.05 hrs
 Peak Elev= 8.48' @ 12.16 hrs Surf.Area= 696 sf Storage= 245 cf

Plug-Flow detention time= 1.7 min calculated for 9,345 cf (100% of inflow)
 Center-of-Mass det. time= 1.7 min (776.4 - 774.6)

Volume	Invert	Avail.Storage	Storage Description
#1	8.00'	710 cf	Custom Stage Data (Prismatic) Listed below (Recalc)
Elevation (feet)	Surf.Area (sq-ft)	Inc.Store (cubic-feet)	Cum.Store (cubic-feet)
8.00	320	0	0
9.00	1,100	710	710

Device	Routing	Invert	Outlet Devices
#1	Secondary	7.00'	12.0" Round Culvert L= 10.0' CPP, square edge headwall, Ke= 0.500 Inlet / Outlet Invert= 7.00' / 6.90' S= 0.0100 '/ Cc= 0.900 n= 0.013, Flow Area= 0.79 sf
#2	Device 1	8.50'	24inch-Dome Grate Capacity X 2.00
#3	Primary	8.00'	15inch-Dome Grate Capacity

Primary OutFlow Max=2.64 cfs @ 12.16 hrs HW=8.47' (Free Discharge)
 ↳3=15inch-Dome Grate Capacity (Custom Controls 2.64 cfs)

Secondary OutFlow Max=0.00 cfs @ 0.00 hrs HW=8.00' (Free Discharge)
 ↳1=Culvert (Passes 0.00 cfs of 2.27 cfs potential flow)
 ↳2=24inch-Dome Grate Capacity (Controls 0.00 cfs)

14850_Proposed-Drainage-Areas_220609

NOAA 24-hr C NOAA 25-yr Rainfall=6.04"

Prepared by {enter your company name here}

Printed 6/16/2022

HydroCAD® 10.10-7a s/n 00546 © 2021 HydroCAD Software Solutions LLC

Page 126

Summary for Pond 3A-P: BB 3A

Inflow Area = 10,987 sf, 58.16% Impervious, Inflow Depth = 4.66" for NOAA 25-yr event
 Inflow = 1.42 cfs @ 12.13 hrs, Volume= 4,271 cf
 Outflow = 1.36 cfs @ 12.15 hrs, Volume= 4,271 cf, Atten= 4%, Lag= 1.2 min
 Discarded = 0.03 cfs @ 12.15 hrs, Volume= 1,429 cf
 Primary = 1.34 cfs @ 12.15 hrs, Volume= 2,842 cf
 Routed to Reach BMP_3 : BMP-3_OVERFLOW

Routing by Stor-Ind method, Time Span= 0.00-72.00 hrs, dt= 0.05 hrs
 Peak Elev= 11.10' @ 12.15 hrs Surf.Area= 917 sf Storage= 472 cf

Plug-Flow detention time= 74.1 min calculated for 4,268 cf (100% of inflow)
 Center-of-Mass det. time= 74.4 min (868.1 - 793.7)

Volume	Invert	Avail.Storage	Storage Description
#1	10.25'	622 cf	Custom Stage Data (Prismatic) Listed below (Recalc)
Elevation (feet)	Surf.Area (sq-ft)	Inc.Store (cubic-feet)	Cum.Store (cubic-feet)
10.25	271	0	0
10.45	350	62	62
11.25	1,050	560	622

Device	Routing	Invert	Outlet Devices
#1	Primary	9.30'	10.0" Round Culvert L= 10.0' CPP, square edge headwall, Ke= 0.500 Inlet / Outlet Invert= 9.30' / 9.20' S= 0.0100 '/ Cc= 0.900 n= 0.013, Flow Area= 0.55 sf
#2	Discarded	10.25'	1.020 in/hr Exfiltration over Surface area Conductivity to Groundwater Elevation = 7.30'
#3	Primary	11.15'	5.0' long Sharp-Crested Rectangular Weir 2 End Contraction(s)
#4	Device 1	10.90'	24inch-Dome Grate Capacity

Discarded OutFlow Max=0.03 cfs @ 12.15 hrs HW=11.10' (Free Discharge)
 ↳2=Exfiltration (Controls 0.03 cfs)

Primary OutFlow Max=1.33 cfs @ 12.15 hrs HW=11.10' (Free Discharge)
 ↳1=Culvert (Passes 1.33 cfs of 3.09 cfs potential flow)
 ↳4=24inch-Dome Grate Capacity (Custom Controls 1.33 cfs)
 ↳3=Sharp-Crested Rectangular Weir (Controls 0.00 cfs)

14850_Proposed-Drainage-Areas_220609

NOAA 24-hr C NOAA 25-yr Rainfall=6.04"

Prepared by {enter your company name here}

Printed 6/16/2022

HydroCAD® 10.10-7a s/n 00546 © 2021 HydroCAD Software Solutions LLC

Page 127

Summary for Pond 3B-P: BB 3B

Inflow Area = 4,545 sf, 77.34% Impervious, Inflow Depth = 5.22" for NOAA 25-yr event
 Inflow = 0.63 cfs @ 12.13 hrs, Volume= 1,978 cf
 Outflow = 0.62 cfs @ 12.14 hrs, Volume= 1,978 cf, Atten= 1%, Lag= 0.9 min
 Discarded = 0.02 cfs @ 12.14 hrs, Volume= 880 cf
 Primary = 0.60 cfs @ 12.14 hrs, Volume= 1,098 cf
 Routed to Reach BMP_3 : BMP-3_OVERFLOW

Routing by Stor-Ind method, Time Span= 0.00-72.00 hrs, dt= 0.05 hrs
 Peak Elev= 12.90' @ 12.14 hrs Surf.Area= 568 sf Storage= 260 cf

Plug-Flow detention time= 88.8 min calculated for 1,976 cf (100% of inflow)
 Center-of-Mass det. time= 88.9 min (863.6 - 774.6)

Volume	Invert	Avail.Storage	Storage Description
#1	12.20'	263 cf	Custom Stage Data (Prismatic) Listed below (Recalc)
Elevation (feet)	Surf.Area (sq-ft)	Inc.Store (cubic-feet)	Cum.Store (cubic-feet)
12.20	180	0	0
12.90	570	263	263

Device	Routing	Invert	Outlet Devices
#1	Primary	10.70'	10.0" Round Culvert L= 10.0' CPP, square edge headwall, Ke= 0.500 Inlet / Outlet Invert= 10.70' / 10.60' S= 0.0100 '/' Cc= 0.900 n= 0.013, Flow Area= 0.55 sf
#2	Discarded	12.20'	1.020 in/hr Exfiltration over Surface area Conductivity to Groundwater Elevation = 8.70'
#3	Device 1	12.80'	24inch-Dome Grate Capacity
#4	Primary	12.85'	5.0' long Sharp-Crested Rectangular Weir 2 End Contraction(s)

Discarded OutFlow Max=0.02 cfs @ 12.14 hrs HW=12.90' (Free Discharge)
 ↳ **2=Exfiltration** (Controls 0.02 cfs)

Primary OutFlow Max=0.59 cfs @ 12.14 hrs HW=12.90' (Free Discharge)
 ↳ **1=Culvert** (Passes 0.43 cfs of 3.50 cfs potential flow)
 ↳ **3=24inch-Dome Grate Capacity** (Custom Controls 0.43 cfs)
 ↳ **4=Sharp-Crested Rectangular Weir** (Weir Controls 0.16 cfs @ 0.69 fps)

14850_Proposed-Drainage-Areas_220609

NOAA 24-hr C NOAA 25-yr Rainfall=6.04"

Prepared by {enter your company name here}

Printed 6/16/2022

HydroCAD® 10.10-7a s/n 00546 © 2021 HydroCAD Software Solutions LLC

Page 128

Summary for Pond 4A-P: BB 4A - POND

Inflow Area = 4,843 sf, 86.37% Impervious, Inflow Depth = 5.45" for NOAA 25-yr event
 Inflow = 0.68 cfs @ 12.13 hrs, Volume= 2,200 cf
 Outflow = 0.66 cfs @ 12.15 hrs, Volume= 2,200 cf, Atten= 3%, Lag= 1.2 min
 Primary = 0.63 cfs @ 12.15 hrs, Volume= 937 cf
 Routed to Reach BMP_3 : BMP-3_OVERFLOW
 Secondary = 0.04 cfs @ 12.15 hrs, Volume= 1,263 cf
 Routed to Pond 4A-S : BB4A-Stone

Routing by Stor-Ind method, Time Span= 0.00-72.00 hrs, dt= 0.05 hrs
 Peak Elev= 10.07' @ 12.15 hrs Surf.Area= 588 sf Storage= 239 cf

Plug-Flow detention time= 29.7 min calculated for 2,200 cf (100% of inflow)
 Center-of-Mass det. time= 29.7 min (794.6 - 764.9)

Volume	Invert	Avail.Storage	Storage Description
#1	9.50'	320 cf	Custom Stage Data (Prismatic) Listed below (Recalc)
Elevation (feet)	Surf.Area (sq-ft)	Inc.Store (cubic-feet)	Cum.Store (cubic-feet)
9.50	250	0	0
10.20	664	320	320

Device	Routing	Invert	Outlet Devices
#1	Primary	8.00'	12.0" Round Culvert L= 10.0' CPP, square edge headwall, Ke= 0.500 Inlet / Outlet Invert= 8.00' / 7.90' S= 0.0100 '/' Cc= 0.900 n= 0.013, Flow Area= 0.79 sf
#2	Secondary	9.50'	2.410 in/hr Exfiltration over Surface area Conductivity to Groundwater Elevation = 6.00'
#3	Primary	10.10'	5.0' long Sharp-Crested Rectangular Weir 2 End Contraction(s)
#4	Device 1	9.95'	24inchDome Grate Capacity Head (feet) 0.00 0.05 0.10 0.15 0.20 0.25 0.30 0.35 0.40 0.45 0.50 0.55 0.60 0.65 0.70 0.75 0.80 0.85 0.90 0.95 1.00 1.05 1.10 Disch. (cfs) 0.000 0.180 0.460 0.850 1.360 1.830 2.420 3.100 3.600 3.800 4.000 4.200 4.380 4.600 4.750 4.900 5.100 5.200 5.350 5.450 5.650 5.800 5.950

Primary OutFlow Max=0.62 cfs @ 12.15 hrs HW=10.07' (Free Discharge)
 ↳ **1=Culvert** (Passes 0.62 cfs of 4.74 cfs potential flow)
 ↳ **4=24inchDome Grate Capacity** (Custom Controls 0.62 cfs)
 ↳ **3=Sharp-Crested Rectangular Weir** (Controls 0.00 cfs)

Secondary OutFlow Max=0.04 cfs @ 12.15 hrs HW=10.07' (Free Discharge)
 ↳ **2=Exfiltration** (Controls 0.04 cfs)

14850_Proposed-Drainage-Areas_220609

NOAA 24-hr C NOAA 25-yr Rainfall=6.04"

Prepared by {enter your company name here}

Printed 6/16/2022

HydroCAD® 10.10-7a s/n 00546 © 2021 HydroCAD Software Solutions LLC

Page 129

Summary for Pond 4A-S: BB4A-Stone

Inflow = 0.04 cfs @ 12.15 hrs, Volume= 1,263 cf
 Outflow = 0.04 cfs @ 12.18 hrs, Volume= 1,246 cf, Atten= 1%, Lag= 2.0 min
 Primary = 0.04 cfs @ 12.18 hrs, Volume= 1,246 cf
 Routed to Reach BMP4_O : BMP-4 OVERFLOW

Routing by Stor-Ind method, Time Span= 0.00-72.00 hrs, dt= 0.05 hrs
 Peak Elev= 7.13' @ 12.18 hrs Surf.Area= 230 sf Storage= 26 cf

Plug-Flow detention time= 23.0 min calculated for 1,246 cf (99% of inflow)
 Center-of-Mass det. time= 14.4 min (853.9 - 839.4)

Volume	Invert	Avail.Storage	Storage Description
#1	6.75'	138 cf	Custom Stage Data (Prismatic) Listed below (Recalc) 460 cf Overall x 30.0% Voids

Elevation (feet)	Surf.Area (sq-ft)	Inc.Store (cubic-feet)	Cum.Store (cubic-feet)
6.75	230	0	0
8.75	230	460	460

Device	Routing	Invert	Outlet Devices
#1	Primary	7.00'	4.0" Vert. Orifice/Grate C= 0.600 Limited to weir flow at low heads

Primary OutFlow Max=0.04 cfs @ 12.18 hrs HW=7.13' (Free Discharge)
 ↳ **1=Orifice/Grate** (Orifice Controls 0.04 cfs @ 1.20 fps)

14850_Proposed-Drainage-Areas_220609

NOAA 24-hr C NOAA 25-yr Rainfall=6.04"

Prepared by {enter your company name here}

Printed 6/16/2022

HydroCAD® 10.10-7a s/n 00546 © 2021 HydroCAD Software Solutions LLC

Page 130

Summary for Pond 4B-P: BB 4B - POND

Inflow Area = 3,048 sf, 86.09% Impervious, Inflow Depth = 5.45" for NOAA 25-yr event
 Inflow = 0.43 cfs @ 12.13 hrs, Volume= 1,385 cf
 Outflow = 0.42 cfs @ 12.14 hrs, Volume= 1,385 cf, Atten= 2%, Lag= 1.0 min
 Primary = 0.40 cfs @ 12.14 hrs, Volume= 597 cf
 Routed to Reach BMP4_O : BMP-4 OVERFLOW
 Secondary = 0.02 cfs @ 12.14 hrs, Volume= 787 cf
 Routed to Pond 4B-S : BB 4A-Stone

Routing by Stor-Ind method, Time Span= 0.00-72.00 hrs, dt= 0.05 hrs
 Peak Elev= 11.04' @ 12.14 hrs Surf.Area= 360 sf Storage= 136 cf

Plug-Flow detention time= 29.1 min calculated for 1,384 cf (100% of inflow)
 Center-of-Mass det. time= 29.1 min (794.0 - 764.9)

Volume	Invert	Avail.Storage	Storage Description
#1	10.50'	199 cf	Custom Stage Data (Prismatic) Listed below (Recalc)

Elevation (feet)	Surf.Area (sq-ft)	Inc.Store (cubic-feet)	Cum.Store (cubic-feet)
10.50	144	0	0
11.20	424	199	199

Device	Routing	Invert	Outlet Devices
#1	Primary	9.00'	12.0" Round Culvert L= 10.0' CPP, square edge headwall, Ke= 0.500 Inlet / Outlet Invert= 9.00' / 8.90' S= 0.0100 '/ Cc= 0.900 n= 0.013, Flow Area= 0.79 sf
#2	Secondary	10.50'	2.410 in/hr Exfiltration over Surface area Conductivity to Groundwater Elevation = 7.00'
#3	Primary	11.10'	5.0' long Sharp-Crested Rectangular Weir 2 End Contraction(s)
#4	Device 1	10.95'	24inch-Dome Grate Capacity

Primary OutFlow Max=0.39 cfs @ 12.14 hrs HW=11.04' (Free Discharge)

↳ **1=Culvert** (Passes 0.39 cfs of 4.69 cfs potential flow)
 ↳ **4=24inch-Dome Grate Capacity** (Custom Controls 0.39 cfs)
 ↳ **3=Sharp-Crested Rectangular Weir** (Controls 0.00 cfs)

Secondary OutFlow Max=0.02 cfs @ 12.14 hrs HW=11.04' (Free Discharge)

↳ **2=Exfiltration** (Controls 0.02 cfs)

14850_Proposed-Drainage-Areas_220609

NOAA 24-hr C NOAA 25-yr Rainfall=6.04"

Prepared by {enter your company name here}

Printed 6/16/2022

HydroCAD® 10.10-7a s/n 00546 © 2021 HydroCAD Software Solutions LLC

Page 131

Summary for Pond 4B-S: BB 4A-Stone

Inflow = 0.02 cfs @ 12.14 hrs, Volume= 787 cf
 Outflow = 0.02 cfs @ 12.17 hrs, Volume= 776 cf, Atten= 1%, Lag= 1.4 min
 Primary = 0.02 cfs @ 12.17 hrs, Volume= 776 cf
 Routed to Reach BMP4_O : BMP-4 OVERFLOW

Routing by Stor-Ind method, Time Span= 0.00-72.00 hrs, dt= 0.05 hrs
 Peak Elev= 7.85' @ 12.17 hrs Surf.Area= 145 sf Storage= 15 cf

Plug-Flow detention time= 22.5 min calculated for 776 cf (99% of inflow)
 Center-of-Mass det. time= 13.4 min (853.5 - 840.1)

Volume	Invert	Avail.Storage	Storage Description
#1	7.50'	87 cf	Custom Stage Data (Prismatic) Listed below (Recalc) 290 cf Overall x 30.0% Voids

Elevation (feet)	Surf.Area (sq-ft)	Inc.Store (cubic-feet)	Cum.Store (cubic-feet)
7.50	145	0	0
9.50	145	290	290

Device	Routing	Invert	Outlet Devices
#1	Primary	7.75'	4.0" Vert. Orifice/Grate C= 0.600 Limited to weir flow at low heads

Primary OutFlow Max=0.02 cfs @ 12.17 hrs HW=7.85' (Free Discharge)
 ↑**1=Orifice/Grate** (Orifice Controls 0.02 cfs @ 1.05 fps)

14850_Proposed-Drainage-Areas_220609

NOAA 24-hr C NOAA 25-yr Rainfall=6.04"

Prepared by {enter your company name here}

Printed 6/16/2022

HydroCAD® 10.10-7a s/n 00546 © 2021 HydroCAD Software Solutions LLC

Page 132

Summary for Pond 5A-P: BB 5A - POND

Inflow Area = 3,072 sf, 73.44% Impervious, Inflow Depth = 5.11" for NOAA 25-yr event
 Inflow = 0.42 cfs @ 12.13 hrs, Volume= 1,308 cf
 Outflow = 0.12 cfs @ 12.37 hrs, Volume= 1,308 cf, Atten= 71%, Lag= 14.6 min
 Primary = 0.07 cfs @ 12.37 hrs, Volume= 72 cf
 Routed to Reach B : PARKING LOT B OVERFLOW
 Secondary = 0.05 cfs @ 12.37 hrs, Volume= 1,236 cf
 Routed to Pond 5A-PS : BB 5A-Stone

Routing by Stor-Ind method, Time Span= 0.00-72.00 hrs, dt= 0.05 hrs
 Peak Elev= 9.52' @ 12.37 hrs Surf.Area= 718 sf Storage= 431 cf

Plug-Flow detention time= 68.7 min calculated for 1,307 cf (100% of inflow)
 Center-of-Mass det. time= 68.6 min (847.6 - 778.9)

Volume	Invert	Avail.Storage	Storage Description
#1	8.80'	645 cf	Custom Stage Data (Prismatic) Listed below (Recalc)

Elevation (feet)	Surf.Area (sq-ft)	Inc.Store (cubic-feet)	Cum.Store (cubic-feet)
8.80	480	0	0
9.80	810	645	645

Device	Routing	Invert	Outlet Devices
#1	Primary	7.60'	12.0" Round Culvert L= 10.0' CPP, square edge headwall, Ke= 0.500 Inlet / Outlet Invert= 7.60' / 7.50' S= 0.0100 '/ Cc= 0.900 n= 0.013, Flow Area= 0.79 sf
#2	Secondary	8.80'	2.410 in/hr Exfiltration over Surface area Conductivity to Groundwater Elevation = 5.60'
#3	Device 1	9.50'	24inch-Dome Grate Capacity

Primary OutFlow Max=0.07 cfs @ 12.37 hrs HW=9.52' (Free Discharge)
 ↑**1=Culvert** (Passes 0.07 cfs of 4.50 cfs potential flow)
 ↑**3=24inch-Dome Grate Capacity**(Custom Controls 0.07 cfs)

Secondary OutFlow Max=0.05 cfs @ 12.37 hrs HW=9.52' (Free Discharge)
 ↑**2=Exfiltration** (Controls 0.05 cfs)

14850_Proposed-Drainage-Areas_220609

NOAA 24-hr C NOAA 25-yr Rainfall=6.04"

Prepared by {enter your company name here}

Printed 6/16/2022

HydroCAD® 10.10-7a s/n 00546 © 2021 HydroCAD Software Solutions LLC

Page 133

Summary for Pond 5A-PS: BB 5A-Stone

Inflow = 0.05 cfs @ 12.37 hrs, Volume= 1,236 cf
 Outflow = 0.05 cfs @ 12.52 hrs, Volume= 1,200 cf, Atten= 0%, Lag= 9.0 min
 Primary = 0.05 cfs @ 12.52 hrs, Volume= 1,200 cf
 Routed to Reach B : PARKING LOT B OVERFLOW

Routing by Stor-Ind method, Time Span= 0.00-72.00 hrs, dt= 0.05 hrs
 Peak Elev= 5.94' @ 12.52 hrs Surf.Area= 480 sf Storage= 57 cf

Plug-Flow detention time= 42.2 min calculated for 1,200 cf (97% of inflow)
 Center-of-Mass det. time= 25.5 min (878.9 - 853.4)

Volume	Invert	Avail.Storage	Storage Description
#1	5.55'	288 cf	Custom Stage Data (Prismatic) Listed below (Recalc) 960 cf Overall x 30.0% Voids

Elevation (feet)	Surf.Area (sq-ft)	Inc.Store (cubic-feet)	Cum.Store (cubic-feet)
5.55	480	0	0
7.55	480	960	960

Device	Routing	Invert	Outlet Devices
#1	Primary	5.80'	4.0" Vert. Orifice/Grate C= 0.600 Limited to weir flow at low heads

Primary OutFlow Max=0.05 cfs @ 12.52 hrs HW=5.94' (Free Discharge)
 ↳ **1=Orifice/Grate** (Orifice Controls 0.05 cfs @ 1.30 fps)

14850_Proposed-Drainage-Areas_220609

NOAA 24-hr C NOAA 25-yr Rainfall=6.04"

Prepared by {enter your company name here}

Printed 6/16/2022

HydroCAD® 10.10-7a s/n 00546 © 2021 HydroCAD Software Solutions LLC

Page 134

Summary for Pond 5B-P: BB 5B - POND

[93] Warning: Storage range exceeded by 0.08'
 [88] Warning: Qout>Qin may require smaller dt or Finer Routing

Inflow Area = 34,755 sf, 71.39% Impervious, Inflow Depth = 5.00" for NOAA 25-yr event
 Inflow = 4.69 cfs @ 12.13 hrs, Volume= 14,471 cf
 Outflow = 4.78 cfs @ 12.12 hrs, Volume= 14,471 cf, Atten= 0%, Lag= 0.0 min
 Primary = 2.32 cfs @ 12.11 hrs, Volume= 1,506 cf
 Routed to Reach B : PARKING LOT B OVERFLOW
 Secondary = 0.09 cfs @ 12.12 hrs, Volume= 4,416 cf
 Routed to Pond 5B-PS : BB 5B-Stone
 Tertiary = 2.36 cfs @ 12.12 hrs, Volume= 8,549 cf
 Routed to Reach 6R : ISOLATOR ROW 2

Routing by Stor-Ind method, Time Span= 0.00-72.00 hrs, dt= 0.05 hrs
 Peak Elev= 9.08' @ 12.12 hrs Surf.Area= 1,450 sf Storage= 711 cf

Plug-Flow detention time= 25.7 min calculated for 14,461 cf (100% of inflow)
 Center-of-Mass det. time= 25.8 min (808.8 - 783.0)

Volume	Invert	Avail.Storage	Storage Description
#1	8.20'	711 cf	Custom Stage Data (Prismatic) Listed below (Recalc)

Elevation (feet)	Surf.Area (sq-ft)	Inc.Store (cubic-feet)	Cum.Store (cubic-feet)
8.20	327	0	0
9.00	1,450	711	711

Device	Routing	Invert	Outlet Devices
#1	Primary	7.00'	12.0" Round Culvert L= 10.0' CPP, square edge headwall, Ke= 0.500 Inlet / Outlet Invert= 7.00' / 6.90' S= 0.0100 '/ Cc= 0.900 n= 0.013, Flow Area= 0.79 sf
#2	Secondary	8.20'	2.410 in/hr Exfiltration over Surface area Conductivity to Groundwater Elevation = 5.00'
#3	Device 1	8.90'	24inchDome Grate Capacity X 2.00 Head (feet) 0.00 0.05 0.10 0.15 0.20 0.25 0.30 0.35 0.40 0.45 0.50 0.55 0.60 0.65 0.70 0.75 0.80 0.85 0.90 0.95 1.00 1.05 1.10 Disch. (cfs) 0.000 0.180 0.460 0.850 1.360 1.830 2.420 3.100 3.600 3.800 4.000 4.200 4.380 4.600 4.750 4.900 5.100 5.200 5.350 5.450 5.650 5.800 5.950
#4	Tertiary	8.70'	15inch-Dome Grate Capacity

14850_Proposed-Drainage-Areas_220609

NOAA 24-hr C NOAA 25-yr Rainfall=6.04"

Prepared by {enter your company name here}

Printed 6/16/2022

HydroCAD® 10.10-7a s/n 00546 © 2021 HydroCAD Software Solutions LLC

Page 135

Primary OutFlow Max=2.16 cfs @ 12.11 hrs HW=9.07' (Free Discharge)

↳ **1=Culvert** (Passes 2.16 cfs of 4.74 cfs potential flow)

↳ **3=24inchDome Grate Capacity** (Custom Controls 2.16 cfs)

Secondary OutFlow Max=0.09 cfs @ 12.12 hrs HW=9.07' (Free Discharge)

↳ **2=Exfiltration** (Controls 0.09 cfs)

Tertiary OutFlow Max=2.32 cfs @ 12.12 hrs HW=9.07' (Free Discharge)

↳ **4=15inch-Dome Grate Capacity** (Custom Controls 2.32 cfs)

14850_Proposed-Drainage-Areas_220609

NOAA 24-hr C NOAA 25-yr Rainfall=6.04"

Prepared by {enter your company name here}

Printed 6/16/2022

HydroCAD® 10.10-7a s/n 00546 © 2021 HydroCAD Software Solutions LLC

Page 136

Summary for Pond 5B-PS: BB 5B-Stone

Inflow = 0.09 cfs @ 12.12 hrs, Volume= 4,416 cf
Outflow = 0.09 cfs @ 12.20 hrs, Volume= 4,364 cf, Atten= 2%, Lag= 4.8 min
Primary = 0.09 cfs @ 12.20 hrs, Volume= 4,364 cf

Routed to Reach B : PARKING LOT B OVERFLOW

Routing by Stor-Ind method, Time Span= 0.00-72.00 hrs, dt= 0.05 hrs

Peak Elev= 5.46' @ 12.20 hrs Surf.Area= 690 sf Storage= 96 cf

Plug-Flow detention time= 26.1 min calculated for 4,364 cf (99% of inflow)

Center-of-Mass det. time= 18.1 min (961.9 - 943.8)

Volume	Invert	Avail.Storage	Storage Description
#1	5.00'	414 cf	Custom Stage Data (Prismatic) Listed below (Recalc) 1,380 cf Overall x 30.0% Voids

Elevation (feet)	Surf.Area (sq-ft)	Inc.Store (cubic-feet)	Cum.Store (cubic-feet)
5.00	690	0	0
7.00	690	1,380	1,380

Device	Routing	Invert	Outlet Devices
#1	Primary	5.25'	4.0" Vert. Orifice/Grate C= 0.600 Limited to weir flow at low heads

Primary OutFlow Max=0.09 cfs @ 12.20 hrs HW=5.46' (Free Discharge)

↳ **1=Orifice/Grate** (Orifice Controls 0.09 cfs @ 1.57 fps)

14850_Proposed-Drainage-Areas_220609

NOAA 24-hr C NOAA 25-yr Rainfall=6.04"

Prepared by {enter your company name here}

Printed 6/16/2022

HydroCAD® 10.10-7a s/n 00546 © 2021 HydroCAD Software Solutions LLC

Page 137

Summary for Pond 6A-P: BB 6A - POND

Inflow Area = 15,148 sf, 46.97% Impervious, Inflow Depth = 4.34" for NOAA 25-yr event
 Inflow = 1.85 cfs @ 12.13 hrs, Volume= 5,479 cf
 Outflow = 1.83 cfs @ 12.14 hrs, Volume= 5,479 cf, Atten= 1%, Lag= 1.0 min
 Primary = 1.78 cfs @ 12.14 hrs, Volume= 3,305 cf
 Routed to Reach BMP6_O : BMP-6 OVERFLOW
 Secondary = 0.05 cfs @ 12.14 hrs, Volume= 2,174 cf
 Routed to Pond 6A-PS : BB 6A - STONE

Routing by Stor-Ind method, Time Span= 0.00-72.00 hrs, dt= 0.05 hrs
 Peak Elev= 11.03' @ 12.14 hrs Surf.Area= 711 sf Storage= 443 cf

Plug-Flow detention time= 38.9 min calculated for 5,475 cf (100% of inflow)
 Center-of-Mass det. time= 39.0 min (842.1 - 803.1)

Volume	Invert	Avail.Storage	Storage Description
#1	10.20'	491 cf	Custom Stage Data (Prismatic) Listed below (Recalc)
Elevation (feet)	Surf.Area (sq-ft)	Inc.Store (cubic-feet)	Cum.Store (cubic-feet)
10.20	350	0	0
11.10	740	491	491

Device	Routing	Invert	Outlet Devices
#1	Primary	9.00'	12.0" Round Culvert L= 10.0' CPP, square edge headwall, Ke= 0.500 Inlet / Outlet Invert= 9.00' / 8.90' S= 0.0100 '/ Cc= 0.900 n= 0.013, Flow Area= 0.79 sf
#2	Secondary	10.20'	2.410 in/hr Exfiltration over Surface area Conductivity to Groundwater Elevation = 7.00'
#3	Device 1	10.80'	24inch-Dome Grate Capacity
#4	Primary	11.00'	5.0' long Sharp-Crested Rectangular Weir 2 End Contraction(s)

Primary OutFlow Max=1.75 cfs @ 12.14 hrs HW=11.03' (Free Discharge)

1=Culvert (Passes 1.66 cfs of 4.68 cfs potential flow)

3=24inch-Dome Grate Capacity (Custom Controls 1.66 cfs)

4=Sharp-Crested Rectangular Weir (Weir Controls 0.09 cfs @ 0.58 fps)

Secondary OutFlow Max=0.05 cfs @ 12.14 hrs HW=11.03' (Free Discharge)

2=Exfiltration (Controls 0.05 cfs)

14850_Proposed-Drainage-Areas_220609

NOAA 24-hr C NOAA 25-yr Rainfall=6.04"

Prepared by {enter your company name here}

Printed 6/16/2022

HydroCAD® 10.10-7a s/n 00546 © 2021 HydroCAD Software Solutions LLC

Page 138

Summary for Pond 6A-PS: BB 6A - STONE

Inflow = 0.05 cfs @ 12.14 hrs, Volume= 2,174 cf
 Outflow = 0.05 cfs @ 12.18 hrs, Volume= 2,152 cf, Atten= 1%, Lag= 2.1 min
 Primary = 0.05 cfs @ 12.18 hrs, Volume= 2,152 cf
 Routed to Reach BMP6_O : BMP-6 OVERFLOW

Routing by Stor-Ind method, Time Span= 0.00-72.00 hrs, dt= 0.05 hrs
 Peak Elev= 7.39' @ 12.18 hrs Surf.Area= 290 sf Storage= 34 cf

Plug-Flow detention time= 17.4 min calculated for 2,152 cf (99% of inflow)
 Center-of-Mass det. time= 11.6 min (997.7 - 986.1)

Volume	Invert	Avail.Storage	Storage Description
#1	7.00'	174 cf	Custom Stage Data (Prismatic) Listed below (Recalc) 580 cf Overall x 30.0% Voids

Elevation (feet)	Surf.Area (sq-ft)	Inc.Store (cubic-feet)	Cum.Store (cubic-feet)
7.00	290	0	0
9.00	290	580	580

Device	Routing	Invert	Outlet Devices
#1	Primary	7.25'	4.0" Vert. Orifice/Grate C= 0.600 Limited to weir flow at low heads

Primary OutFlow Max=0.05 cfs @ 12.18 hrs HW=7.39' (Free Discharge)

1=Orifice/Grate (Orifice Controls 0.05 cfs @ 1.29 fps)

14850_Proposed-Drainage-Areas_220609

NOAA 24-hr C NOAA 25-yr Rainfall=6.04"

Prepared by {enter your company name here}

Printed 6/16/2022

HydroCAD® 10.10-7a s/n 00546 © 2021 HydroCAD Software Solutions LLC

Page 139

Summary for Pond 6B-P: BB 6B

Inflow Area = 6,495 sf, 77.45% Impervious, Inflow Depth = 5.22" for NOAA 25-yr event
 Inflow = 0.90 cfs @ 12.13 hrs, Volume= 2,826 cf
 Outflow = 0.86 cfs @ 12.15 hrs, Volume= 2,826 cf, Atten= 4%, Lag= 1.2 min
 Discarded = 0.02 cfs @ 12.15 hrs, Volume= 1,170 cf
 Primary = 0.84 cfs @ 12.15 hrs, Volume= 1,657 cf
 Routed to Reach BMP6_O : BMP-6 OVERFLOW

Routing by Stor-Ind method, Time Span= 0.00-72.00 hrs, dt= 0.05 hrs
 Peak Elev= 12.10' @ 12.15 hrs Surf.Area= 690 sf Storage= 393 cf

Plug-Flow detention time= 99.9 min calculated for 2,824 cf (100% of inflow)
 Center-of-Mass det. time= 100.2 min (874.8 - 774.6)

Volume	Invert	Avail.Storage	Storage Description
#1	11.20'	394 cf	Custom Stage Data (Prismatic) Listed below (Recalc)
Elevation (feet)	Surf.Area (sq-ft)	Inc.Store (cubic-feet)	Cum.Store (cubic-feet)
11.20	185	0	0
12.10	690	394	394

Device	Routing	Invert	Outlet Devices
#1	Primary	10.10'	12.0" Round Culvert L= 10.0' CPP, square edge headwall, Ke= 0.500 Inlet / Outlet Invert= 10.10' / 10.00' S= 0.0100 '/ Cc= 0.900 n= 0.013, Flow Area= 0.79 sf
#2	Discarded	11.20'	1.020 in/hr Exfiltration over Surface area Conductivity to Groundwater Elevation = 8.10'
#3	Device 1	11.95'	24inch-Dome Grate Capacity

Discarded OutFlow Max=0.02 cfs @ 12.15 hrs HW=12.10' (Free Discharge)
 ↳2=Exfiltration (Controls 0.02 cfs)

Primary OutFlow Max=0.84 cfs @ 12.15 hrs HW=12.10' (Free Discharge)
 ↳1=Culvert (Passes 0.84 cfs of 4.63 cfs potential flow)
 ↳3=24inch-Dome Grate Capacity (Custom Controls 0.84 cfs)

14850_Proposed-Drainage-Areas_220609

NOAA 24-hr C NOAA 25-yr Rainfall=6.04"

Prepared by {enter your company name here}

Printed 6/16/2022

HydroCAD® 10.10-7a s/n 00546 © 2021 HydroCAD Software Solutions LLC

Page 140

Summary for Pond 7A-P: BB 7A PONDING

Inflow Area = 3,165 sf, 87.74% Impervious, Inflow Depth = 5.45" for NOAA 25-yr event
 Inflow = 0.45 cfs @ 12.13 hrs, Volume= 1,438 cf
 Outflow = 0.44 cfs @ 12.14 hrs, Volume= 1,438 cf, Atten= 2%, Lag= 0.9 min
 Primary = 0.42 cfs @ 12.14 hrs, Volume= 638 cf
 Routed to Reach 7R : PARKING LOT C to HUDSON
 Secondary = 0.02 cfs @ 12.14 hrs, Volume= 800 cf
 Routed to Pond 7A-S : BB 7A - STONE

Routing by Stor-Ind method, Time Span= 0.00-72.00 hrs, dt= 0.05 hrs
 Peak Elev= 9.99' @ 12.14 hrs Surf.Area= 327 sf Storage= 153 cf

Plug-Flow detention time= 38.3 min calculated for 1,437 cf (100% of inflow)
 Center-of-Mass det. time= 38.3 min (803.2 - 764.9)

Volume	Invert	Avail.Storage	Storage Description
#1	9.30'	227 cf	Custom Stage Data (Prismatic) Listed below (Recalc)
Elevation (feet)	Surf.Area (sq-ft)	Inc.Store (cubic-feet)	Cum.Store (cubic-feet)
9.30	115	0	0
10.20	390	227	227

Device	Routing	Invert	Outlet Devices
#1	Primary	8.10'	12.0" Round Culvert L= 10.0' CPP, square edge headwall, Ke= 0.500 Inlet / Outlet Invert= 8.10' / 8.00' S= 0.0100 '/ Cc= 0.900 n= 0.013, Flow Area= 0.79 sf
#2	Secondary	9.30'	2.410 in/hr Exfiltration over Surface area Conductivity to Groundwater Elevation = 6.10'
#3	Device 1	9.90'	24inch-Dome Grate Capacity
#4	Primary	10.10'	5.0' long Sharp-Crested Rectangular Weir 2 End Contraction(s)

Primary OutFlow Max=0.41 cfs @ 12.14 hrs HW=9.99' (Free Discharge)
 ↳1=Culvert (Passes 0.41 cfs of 4.46 cfs potential flow)
 ↳3=24inch-Dome Grate Capacity (Custom Controls 0.41 cfs)
 ↳4=Sharp-Crested Rectangular Weir (Controls 0.00 cfs)

Secondary OutFlow Max=0.02 cfs @ 12.14 hrs HW=9.99' (Free Discharge)
 ↳2=Exfiltration (Controls 0.02 cfs)

14850_Proposed-Drainage-Areas_220609

NOAA 24-hr C NOAA 25-yr Rainfall=6.04"

Prepared by {enter your company name here}

Printed 6/16/2022

HydroCAD® 10.10-7a s/n 00546 © 2021 HydroCAD Software Solutions LLC

Page 141

Summary for Pond 7A-S: BB 7A - STONE

Inflow = 0.02 cfs @ 12.14 hrs, Volume= 800 cf
 Outflow = 0.02 cfs @ 12.17 hrs, Volume= 800 cf, Atten= 1%, Lag= 1.5 min
 Primary = 0.02 cfs @ 12.17 hrs, Volume= 800 cf
 Routed to Reach 7R : PARKING LOT C to HUDSON

Routing by Stor-Ind method, Time Span= 0.00-72.00 hrs, dt= 0.05 hrs
 Peak Elev= 5.19' @ 12.17 hrs Surf.Area= 150 sf Storage= 4 cf

Plug-Flow detention time= 4.6 min calculated for 800 cf (100% of inflow)
 Center-of-Mass det. time= 4.5 min (863.0 - 858.4)

Volume	Invert	Avail.Storage	Storage Description
#1	5.10'	90 cf	Custom Stage Data (Prismatic) Listed below (Recalc) 300 cf Overall x 30.0% Voids

Elevation (feet)	Surf.Area (sq-ft)	Inc.Store (cubic-feet)	Cum.Store (cubic-feet)
5.10	150	0	0
7.10	150	300	300

Device	Routing	Invert	Outlet Devices
#1	Primary	5.10'	4.0" Vert. Orifice/Grate C= 0.600 Limited to weir flow at low heads

Primary OutFlow Max=0.02 cfs @ 12.17 hrs HW=5.19' (Free Discharge)
 ↑**1=Orifice/Grate** (Orifice Controls 0.02 cfs @ 1.04 fps)

14850_Proposed-Drainage-Areas_220609

NOAA 24-hr C NOAA 25-yr Rainfall=6.04"

Prepared by {enter your company name here}

Printed 6/16/2022

HydroCAD® 10.10-7a s/n 00546 © 2021 HydroCAD Software Solutions LLC

Page 142

Summary for Pond 7B-P: BB 7B PONDING

Inflow Area = 4,942 sf, 88.73% Impervious, Inflow Depth = 5.45" for NOAA 25-yr event
 Inflow = 0.70 cfs @ 12.13 hrs, Volume= 2,245 cf
 Outflow = 0.68 cfs @ 12.14 hrs, Volume= 2,245 cf, Atten= 2%, Lag= 1.1 min
 Primary = 0.65 cfs @ 12.14 hrs, Volume= 940 cf
 Routed to Reach BMP7_O : BMP-7 OVERFLOW
 Secondary = 0.03 cfs @ 12.14 hrs, Volume= 1,305 cf
 Routed to Pond 7B-S : BB 7B - STONE

Routing by Stor-Ind method, Time Span= 0.00-72.00 hrs, dt= 0.05 hrs
 Peak Elev= 10.72' @ 12.14 hrs Surf.Area= 530 sf Storage= 282 cf

Plug-Flow detention time= 40.1 min calculated for 2,243 cf (100% of inflow)
 Center-of-Mass det. time= 40.0 min (804.9 - 764.9)

Volume	Invert	Avail.Storage	Storage Description
#1	10.00'	324 cf	Custom Stage Data (Prismatic) Listed below (Recalc)

Elevation (feet)	Surf.Area (sq-ft)	Inc.Store (cubic-feet)	Cum.Store (cubic-feet)
10.00	250	0	0
10.80	560	324	324

Device	Routing	Invert	Outlet Devices
#1	Primary	8.90'	12.0" Round Culvert L= 10.0' CPP, square edge headwall, Ke= 0.500 Inlet / Outlet Invert= 8.90' / 8.80' S= 0.0100 '/ Cc= 0.900 n= 0.013, Flow Area= 0.79 sf
#2	Secondary	10.00'	2.410 in/hr Exfiltration over Surface area Conductivity to Groundwater Elevation = 6.90'
#3	Device 1	10.60'	24inch-Dome Grate Capacity

Primary OutFlow Max=0.63 cfs @ 12.14 hrs HW=10.72' (Free Discharge)
 ↑**1=Culvert** (Passes 0.63 cfs of 4.35 cfs potential flow)
 ↑**3=24inch-Dome Grate Capacity**(Custom Controls 0.63 cfs)

Secondary OutFlow Max=0.03 cfs @ 12.14 hrs HW=10.72' (Free Discharge)
 ↑**2=Exfiltration** (Controls 0.03 cfs)

14850_Proposed-Drainage-Areas_220609

NOAA 24-hr C NOAA 25-yr Rainfall=6.04"

Prepared by {enter your company name here}

Printed 6/16/2022

HydroCAD® 10.10-7a s/n 00546 © 2021 HydroCAD Software Solutions LLC

Page 143

Summary for Pond 7B-S: BB 7B - STONE

Inflow = 0.03 cfs @ 12.14 hrs, Volume= 1,305 cf
 Outflow = 0.03 cfs @ 12.17 hrs, Volume= 1,294 cf, Atten= 0%, Lag= 1.3 min
 Primary = 0.03 cfs @ 12.17 hrs, Volume= 1,294 cf
 Routed to Reach BMP7_O : BMP-7 OVERFLOW

Routing by Stor-Ind method, Time Span= 0.00-72.00 hrs, dt= 0.05 hrs
 Peak Elev= 7.62' @ 12.17 hrs Surf.Area= 150 sf Storage= 17 cf

Plug-Flow detention time= 14.5 min calculated for 1,293 cf (99% of inflow)
 Center-of-Mass det. time= 9.5 min (864.4 - 855.0)

Volume	Invert	Avail.Storage	Storage Description
#1	7.25'	90 cf	Custom Stage Data (Prismatic) Listed below (Recalc) 300 cf Overall x 30.0% Voids

Elevation (feet)	Surf.Area (sq-ft)	Inc.Store (cubic-feet)	Cum.Store (cubic-feet)
7.25	150	0	0
9.25	150	300	300

Device	Routing	Invert	Outlet Devices
#1	Primary	7.50'	4.0" Vert. Orifice/Grate C= 0.600 Limited to weir flow at low heads

Primary OutFlow Max=0.03 cfs @ 12.17 hrs HW=7.62' (Free Discharge)
 ↳1=Orifice/Grate (Orifice Controls 0.03 cfs @ 1.19 fps)

14850_Proposed-Drainage-Areas_220609

NOAA 24-hr C NOAA 25-yr Rainfall=6.04"

Prepared by {enter your company name here}

Printed 6/16/2022

HydroCAD® 10.10-7a s/n 00546 © 2021 HydroCAD Software Solutions LLC

Page 144

Summary for Pond 8a-P: BB 8A PONDING

Inflow Area = 3,978 sf, 79.99% Impervious, Inflow Depth = 5.22" for NOAA 25-yr event
 Inflow = 0.55 cfs @ 12.13 hrs, Volume= 1,731 cf
 Outflow = 0.52 cfs @ 12.15 hrs, Volume= 1,731 cf, Atten= 5%, Lag= 1.4 min
 Primary = 0.48 cfs @ 12.15 hrs, Volume= 547 cf
 Routed to Reach P ST : PORTLAND STREET DRAINAGE
 Secondary = 0.04 cfs @ 12.15 hrs, Volume= 1,184 cf
 Routed to Pond 8a-s : BB 8A - STONE

Routing by Stor-Ind method, Time Span= 0.00-72.00 hrs, dt= 0.05 hrs
 Peak Elev= 9.10' @ 12.15 hrs Surf.Area= 619 sf Storage= 295 cf

Plug-Flow detention time= 37.1 min calculated for 1,730 cf (100% of inflow)
 Center-of-Mass det. time= 37.1 min (811.7 - 774.6)

Volume	Invert	Avail.Storage	Storage Description
#1	8.50'	575 cf	Custom Stage Data (Prismatic) Listed below (Recalc)

Elevation (feet)	Surf.Area (sq-ft)	Inc.Store (cubic-feet)	Cum.Store (cubic-feet)
8.50	360	0	0
9.50	790	575	575

Device	Routing	Invert	Outlet Devices
#1	Primary	7.40'	12.0" Round Culvert L= 10.0' CPP, square edge headwall, Ke= 0.500 Inlet / Outlet Invert= 7.40' / 7.30' S= 0.0100 '/ Cc= 0.900 n= 0.013, Flow Area= 0.79 sf
#2	Secondary	8.50'	2.410 in/hr Exfiltration over Surface area Conductivity to Groundwater Elevation = 5.40'
#3	Device 1	9.00'	24inch-Dome Grate Capacity
#4	Primary	9.40'	5.0' long Sharp-Crested Rectangular Weir 2 End Contraction(s)

Primary OutFlow Max=0.48 cfs @ 12.15 hrs HW=9.10' (Free Discharge)
 ↳1=Culvert (Passes 0.48 cfs of 4.15 cfs potential flow)
 ↳3=24inch-Dome Grate Capacity (Custom Controls 0.48 cfs)
 ↳4=Sharp-Crested Rectangular Weir (Controls 0.00 cfs)

Secondary OutFlow Max=0.04 cfs @ 12.15 hrs HW=9.10' (Free Discharge)
 ↳2=Exfiltration (Controls 0.04 cfs)

14850_Proposed-Drainage-Areas_220609

NOAA 24-hr C NOAA 25-yr Rainfall=6.04"

Prepared by {enter your company name here}

Printed 6/16/2022

HydroCAD® 10.10-7a s/n 00546 © 2021 HydroCAD Software Solutions LLC

Page 145

Summary for Pond 8a-s: BB 8A - STONE

Inflow = 0.04 cfs @ 12.15 hrs, Volume= 1,184 cf
 Outflow = 0.04 cfs @ 12.20 hrs, Volume= 1,166 cf, Atten= 1%, Lag= 2.7 min
 Primary = 0.04 cfs @ 12.20 hrs, Volume= 1,166 cf
 Routed to Reach P ST : PORTLAND STREET DRAINAGE

Routing by Stor-Ind method, Time Span= 0.00-72.00 hrs, dt= 0.05 hrs
 Peak Elev= 5.63' @ 12.20 hrs Surf.Area= 300 sf Storage= 30 cf

Plug-Flow detention time= 25.0 min calculated for 1,165 cf (98% of inflow)
 Center-of-Mass det. time= 16.2 min (862.5 - 846.3)

Volume	Invert	Avail.Storage	Storage Description
#1	5.30'	180 cf	Custom Stage Data (Prismatic) Listed below (Recalc) 600 cf Overall x 30.0% Voids

Elevation (feet)	Surf.Area (sq-ft)	Inc.Store (cubic-feet)	Cum.Store (cubic-feet)
5.30	300	0	0
7.30	300	600	600

Device	Routing	Invert	Outlet Devices
#1	Primary	5.50'	4.0" Vert. Orifice/Grate C= 0.600 Limited to weir flow at low heads

Primary OutFlow Max=0.04 cfs @ 12.20 hrs HW=5.63' (Free Discharge)

↑**1=Orifice/Grate** (Orifice Controls 0.04 cfs @ 1.23 fps)

14850_Proposed-Drainage-Areas_220609

NOAA 24-hr C NOAA 25-yr Rainfall=6.04"

Prepared by {enter your company name here}

Printed 6/16/2022

HydroCAD® 10.10-7a s/n 00546 © 2021 HydroCAD Software Solutions LLC

Page 146

Summary for Pond 8B-P: BB 8B-PONDING

Inflow Area = 5,598 sf, 87.78% Impervious, Inflow Depth = 5.45" for NOAA 25-yr event
 Inflow = 0.79 cfs @ 12.13 hrs, Volume= 2,543 cf
 Outflow = 0.78 cfs @ 12.14 hrs, Volume= 2,543 cf, Atten= 2%, Lag= 0.9 min
 Primary = 0.74 cfs @ 12.14 hrs, Volume= 1,102 cf
 Routed to Reach 7R : PARKING LOT C to HUDSON

Secondary = 0.04 cfs @ 12.14 hrs, Volume= 1,441 cf
 Routed to Pond 8B-S : BB 8B-Stone

Routing by Stor-Ind method, Time Span= 0.00-72.00 hrs, dt= 0.05 hrs
 Peak Elev= 9.73' @ 12.14 hrs Surf.Area= 638 sf Storage= 262 cf

Plug-Flow detention time= 34.7 min calculated for 2,541 cf (100% of inflow)
 Center-of-Mass det. time= 34.7 min (799.6 - 764.9)

Volume	Invert	Avail.Storage	Storage Description
#1	9.10'	306 cf	Custom Stage Data (Prismatic) Listed below (Recalc)

Elevation (feet)	Surf.Area (sq-ft)	Inc.Store (cubic-feet)	Cum.Store (cubic-feet)
9.10	190	0	0
9.80	685	306	306

Device	Routing	Invert	Outlet Devices
#1	Primary	7.90'	12.0" Round Culvert L= 10.0' CPP, square edge headwall, Ke= 0.500 Inlet / Outlet Invert= 7.90' / 7.80' S= 0.0100 '/ Cc= 0.900 n= 0.013, Flow Area= 0.79 sf
#2	Secondary	9.10'	2.410 in/hr Exfiltration over Surface area Conductivity to Groundwater Elevation = 5.90'
#3	Device 1	9.65'	24inch-Dome Grate Capacity X 2.00

Primary OutFlow Max=0.72 cfs @ 12.14 hrs HW=9.73' (Free Discharge)

↑**1=Culvert** (Passes 0.72 cfs of 4.36 cfs potential flow)

↑**3=24inch-Dome Grate Capacity**(Custom Controls 0.72 cfs)

Secondary OutFlow Max=0.04 cfs @ 12.14 hrs HW=9.73' (Free Discharge)

↑**2=Exfiltration** (Controls 0.04 cfs)

14850_Proposed-Drainage-Areas_220609

NOAA 24-hr C NOAA 25-yr Rainfall=6.04"

Prepared by {enter your company name here}

Printed 6/16/2022

HydroCAD® 10.10-7a s/n 00546 © 2021 HydroCAD Software Solutions LLC

Page 147

Summary for Pond 8B-S: BB 8B-Stone

Inflow = 0.04 cfs @ 12.14 hrs, Volume= 1,441 cf
 Outflow = 0.04 cfs @ 12.18 hrs, Volume= 1,414 cf, Atten= 1%, Lag= 2.2 min
 Primary = 0.04 cfs @ 12.18 hrs, Volume= 1,414 cf
 Routed to Reach 7R : PARKING LOT C to HUDSON

Routing by Stor-Ind method, Time Span= 0.00-72.00 hrs, dt= 0.05 hrs
 Peak Elev= 6.33' @ 12.18 hrs Surf.Area= 300 sf Storage= 39 cf

Plug-Flow detention time= 30.1 min calculated for 1,414 cf (98% of inflow)
 Center-of-Mass det. time= 19.0 min (869.3 - 850.3)

Volume	Invert	Avail.Storage	Storage Description
#1	5.90'	180 cf	Custom Stage Data (Prismatic) Listed below (Recalc) 600 cf Overall x 30.0% Voids

Elevation (feet)	Surf.Area (sq-ft)	Inc.Store (cubic-feet)	Cum.Store (cubic-feet)
5.90	300	0	0
7.90	300	600	600

Device	Routing	Invert	Outlet Devices
#1	Primary	6.20'	4.0" Vert. Orifice/Grate C= 0.600 Limited to weir flow at low heads

Primary OutFlow Max=0.04 cfs @ 12.18 hrs HW=6.33' (Free Discharge)
 ↳1=Orifice/Grate (Orifice Controls 0.04 cfs @ 1.23 fps)

14850_Proposed-Drainage-Areas_220609

NOAA 24-hr C NOAA 25-yr Rainfall=6.04"

Prepared by {enter your company name here}

Printed 6/16/2022

HydroCAD® 10.10-7a s/n 00546 © 2021 HydroCAD Software Solutions LLC

Page 148

Summary for Pond 9-P: BB9 - POND

Inflow Area = 29,651 sf, 74.77% Impervious, Inflow Depth = 5.11" for NOAA 25-yr event
 Inflow = 4.05 cfs @ 12.13 hrs, Volume= 12,623 cf
 Outflow = 3.97 cfs @ 12.14 hrs, Volume= 12,623 cf, Atten= 2%, Lag= 1.0 min
 Primary = 1.24 cfs @ 12.15 hrs, Volume= 542 cf
 Routed to Reach BMP9_O : BMP-9 OVERFLOW
 Secondary = 0.05 cfs @ 12.14 hrs, Volume= 2,332 cf
 Routed to Pond 9-PS : BB9 - STONE
 Tertiary = 2.68 cfs @ 12.14 hrs, Volume= 9,749 cf
 Routed to Reach 1R : ISOLATOR ROW C

Routing by Stor-Ind method, Time Span= 0.00-72.00 hrs, dt= 0.05 hrs
 Peak Elev= 8.99' @ 12.14 hrs Surf.Area= 773 sf Storage= 476 cf

Plug-Flow detention time= 16.7 min calculated for 12,615 cf (100% of inflow)
 Center-of-Mass det. time= 16.8 min (795.7 - 778.9)

Volume	Invert	Avail.Storage	Storage Description
#1	8.00'	485 cf	Custom Stage Data (Prismatic) Listed below (Recalc)

Elevation (feet)	Surf.Area (sq-ft)	Inc.Store (cubic-feet)	Cum.Store (cubic-feet)
8.00	190	0	0
9.00	780	485	485

Device	Routing	Invert	Outlet Devices
#1	Primary	7.00'	12.0" Round Culvert L= 10.0' CPP, square edge headwall, Ke= 0.500 Inlet / Outlet Invert= 7.00' / 6.90' S= 0.0100 '/ Cc= 0.900 n= 0.013, Flow Area= 0.79 sf
#2	Secondary	8.00'	2.410 in/hr Exfiltration over Surface area Conductivity to Groundwater Elevation = 5.00'
#3	Device 1	8.80'	24inchDome Grate Capacity Head (feet) 0.00 0.05 0.10 0.15 0.20 0.25 0.30 0.35 0.40 0.45 0.50 0.55 0.60 0.65 0.70 0.75 0.80 0.85 0.90 0.95 1.00 1.05 1.10 Disch. (cfs) 0.000 0.180 0.460 0.850 1.360 1.830 2.420 3.100 3.600 3.800 4.000 4.200 4.380 4.600 4.750 4.900 5.100 5.200 5.350 5.450 5.650 5.800 5.950
#4	Tertiary	8.50'	15inch-Dome Grate Capacity

Primary OutFlow Max=1.19 cfs @ 12.15 hrs HW=8.98' (Free Discharge)
 ↳1=Culvert (Passes 1.19 cfs of 4.61 cfs potential flow)
 ↳3=24inchDome Grate Capacity (Custom Controls 1.19 cfs)

Secondary OutFlow Max=0.05 cfs @ 12.14 hrs HW=8.98' (Free Discharge)
 ↳2=Exfiltration (Controls 0.05 cfs)

Tertiary OutFlow Max=2.66 cfs @ 12.14 hrs HW=8.98' (Free Discharge)
 ↳4=15inch-Dome Grate Capacity (Custom Controls 2.66 cfs)

14850_Proposed-Drainage-Areas_220609

NOAA 24-hr C NOAA 25-yr Rainfall=6.04"

Prepared by {enter your company name here}

Printed 6/16/2022

HydroCAD® 10.10-7a s/n 00546 © 2021 HydroCAD Software Solutions LLC

Page 149

Summary for Pond 9-PS: BB9 - STONE

Inflow = 0.05 cfs @ 12.14 hrs, Volume= 2,332 cf
 Outflow = 0.05 cfs @ 12.17 hrs, Volume= 2,318 cf, Atten= 2%, Lag= 1.5 min
 Primary = 0.05 cfs @ 12.17 hrs, Volume= 2,318 cf
 Routed to Reach BMP9_O : BMP-9 OVERFLOW

Routing by Stor-Ind method, Time Span= 0.00-72.00 hrs, dt= 0.05 hrs
 Peak Elev= 5.40' @ 12.17 hrs Surf.Area= 190 sf Storage= 23 cf

Plug-Flow detention time= 12.5 min calculated for 2,318 cf (99% of inflow)
 Center-of-Mass det. time= 8.1 min (924.3 - 916.2)

Volume	Invert	Avail.Storage	Storage Description
#1	5.00'	114 cf	Custom Stage Data (Prismatic) Listed below (Recalc) 380 cf Overall x 30.0% Voids

Elevation (feet)	Surf.Area (sq-ft)	Inc.Store (cubic-feet)	Cum.Store (cubic-feet)
5.00	190	0	0
7.00	190	380	380

Device	Routing	Invert	Outlet Devices
#1	Primary	5.25'	4.0" Vert. Orifice/Grate C= 0.600 Limited to weir flow at low heads

Primary OutFlow Max=0.05 cfs @ 12.17 hrs HW=5.40' (Free Discharge)
 ↳ **1=Orifice/Grate** (Orifice Controls 0.05 cfs @ 1.32 fps)

14850_Proposed-Drainage-Areas_220609

NOAA 24-hr C NOAA 25-yr Rainfall=6.04"

Prepared by {enter your company name here}

Printed 6/16/2022

HydroCAD® 10.10-7a s/n 00546 © 2021 HydroCAD Software Solutions LLC

Page 150

Summary for Pond 14P: BB2A-Stone

Inflow = 0.03 cfs @ 12.14 hrs, Volume= 978 cf
 Outflow = 0.03 cfs @ 12.17 hrs, Volume= 978 cf, Atten= 0%, Lag= 1.7 min
 Primary = 0.03 cfs @ 12.17 hrs, Volume= 978 cf
 Routed to Reach DP-1 : French Rodney Blvd Outfall

Routing by Stor-Ind method, Time Span= 0.00-72.00 hrs, dt= 0.05 hrs
 Peak Elev= 5.61' @ 12.17 hrs Surf.Area= 180 sf Storage= 6 cf

Plug-Flow detention time= 5.0 min calculated for 978 cf (100% of inflow)
 Center-of-Mass det. time= 4.9 min (860.1 - 855.2)

Volume	Invert	Avail.Storage	Storage Description
#1	5.50'	108 cf	Custom Stage Data (Prismatic) Listed below (Recalc) 360 cf Overall x 30.0% Voids

Elevation (feet)	Surf.Area (sq-ft)	Inc.Store (cubic-feet)	Cum.Store (cubic-feet)
5.50	180	0	0
7.50	180	360	360

Device	Routing	Invert	Outlet Devices
#1	Primary	5.50'	4.0" Vert. Orifice/Grate C= 0.600 Limited to weir flow at low heads

Primary OutFlow Max=0.03 cfs @ 12.17 hrs HW=5.61' (Free Discharge)
 ↳ **1=Orifice/Grate** (Orifice Controls 0.03 cfs @ 1.11 fps)

14850_Proposed-Drainage-Areas_220609

NOAA 24-hr C NOAA 25-yr Rainfall=6.04"

Prepared by {enter your company name here}

Printed 6/16/2022

HydroCAD® 10.10-7a s/n 00546 © 2021 HydroCAD Software Solutions LLC

Page 151

Summary for Pond DMH1: DIVERSION MANHOLE - SEYMOUR ST

[57] Hint: Peaked at 9.92' (Flood elevation advised)

Inflow Area = 19,582 sf, 58.17% Impervious, Inflow Depth = 4.66" for NOAA 25-yr event
 Inflow = 2.53 cfs @ 12.13 hrs, Volume= 7,612 cf
 Outflow = 2.53 cfs @ 12.13 hrs, Volume= 7,612 cf, Atten= 0%, Lag= 0.0 min
 Primary = 0.78 cfs @ 12.13 hrs, Volume= 5,625 cf
 Routed to Pond INF-1 : INFILTRATION SYSTEM #1
 Secondary = 1.75 cfs @ 12.13 hrs, Volume= 1,987 cf
 Routed to Reach DP-1 : French Rodney Blvd Outfall

Routing by Stor-Ind method, Time Span= 0.00-72.00 hrs, dt= 0.05 hrs

Peak Elev= 9.92' @ 12.13 hrs

Device	Routing	Invert	Outlet Devices
#1	Primary	9.00'	6.0" Vert. WATER QUALITY STORM DIVERSION C= 0.600 Limited to weir flow at low heads
#2	Secondary	9.20'	12.0" Vert. LARGE STORM OVEFLOW C= 0.600 Limited to weir flow at low heads

Primary OutFlow Max=0.76 cfs @ 12.13 hrs HW=9.90' (Free Discharge)

↳1=WATER QUALITY STORM DIVERSION(Orifice Controls 0.76 cfs @ 3.88 fps)

Secondary OutFlow Max=1.66 cfs @ 12.13 hrs HW=9.90' (Free Discharge)

↳2=LARGE STORM OVEFLOW(Orifice Controls 1.66 cfs @ 2.84 fps)

14850_Proposed-Drainage-Areas_220609

NOAA 24-hr C NOAA 25-yr Rainfall=6.04"

Prepared by {enter your company name here}

Printed 6/16/2022

HydroCAD® 10.10-7a s/n 00546 © 2021 HydroCAD Software Solutions LLC

Page 152

Summary for Pond DMH2: DIVERSION MANHOLE - HUDSON STREET

[57] Hint: Peaked at 25.58' (Flood elevation advised)

Inflow Area = 143,309 sf, 49.69% Impervious, Inflow Depth = 4.45" for NOAA 25-yr event
 Inflow = 17.88 cfs @ 12.13 hrs, Volume= 53,113 cf
 Outflow = 17.88 cfs @ 12.13 hrs, Volume= 53,113 cf, Atten= 0%, Lag= 0.0 min
 Primary = 3.65 cfs @ 12.13 hrs, Volume= 28,364 cf
 Routed to Pond INF-2 : INFILTRATION SYSTEM #2
 Secondary = 14.23 cfs @ 12.13 hrs, Volume= 24,749 cf
 Routed to Reach B : PARKING LOT B OVERFLOW

Routing by Stor-Ind method, Time Span= 0.00-72.00 hrs, dt= 0.05 hrs

Peak Elev= 25.58' @ 12.13 hrs

Device	Routing	Invert	Outlet Devices
#1	Primary	10.60'	6.0" Vert. WATER QUALITY STORM DIVERSION C= 0.600 Limited to weir flow at low heads
#2	Secondary	11.10'	12.0" Vert. LARGE STORM OVERFLOW C= 0.600 Limited to weir flow at low heads

Primary OutFlow Max=3.51 cfs @ 12.13 hrs HW=24.62' (Free Discharge)

↳1=WATER QUALITY STORM DIVERSION(Orifice Controls 3.51 cfs @ 17.87 fps)

Secondary OutFlow Max=13.65 cfs @ 12.13 hrs HW=24.62' (Free Discharge)

↳2=LARGE STORM OVERFLOW(Orifice Controls 13.65 cfs @ 17.38 fps)

14850_Proposed-Drainage-Areas_220609

NOAA 24-hr C NOAA 25-yr Rainfall=6.04"

Prepared by {enter your company name here}

Printed 6/16/2022

HydroCAD® 10.10-7a s/n 00546 © 2021 HydroCAD Software Solutions LLC

Page 153

Summary for Pond DMH3: DIVERSION MANHOLE - PORTLAND ST

[57] Hint: Peaked at 11.85' (Flood elevation advised)

Inflow Area = 19,743 sf, 50.83% Impervious, Inflow Depth = 4.45" for NOAA 25-yr event
 Inflow = 2.46 cfs @ 12.13 hrs, Volume= 7,317 cf
 Outflow = 2.46 cfs @ 12.13 hrs, Volume= 7,317 cf, Atten= 0%, Lag= 0.0 min
 Primary = 1.21 cfs @ 12.13 hrs, Volume= 6,020 cf
 Routed to Pond INF3 : INFILTRATION SYSTEM #1
 Secondary = 1.25 cfs @ 12.13 hrs, Volume= 1,297 cf
 Routed to Reach P ST : PORTLAND STREET DRAINAGE

Routing by Stor-Ind method, Time Span= 0.00-72.00 hrs, dt= 0.05 hrs
 Peak Elev= 11.85' @ 12.13 hrs

Device	Routing	Invert	Outlet Devices
#1	Primary	11.00'	8.0" Vert. WATER QUALITY DIVERSION C= 0.600 Limited to weir flow at low heads
#2	Secondary	11.20'	10.0" Vert. LARGE STORM OVERFLOW C= 0.600 Limited to weir flow at low heads

Primary OutFlow Max=1.18 cfs @ 12.13 hrs HW=11.83' (Free Discharge)
 ↳1=WATER QUALITY DIVERSION(Orifice Controls 1.18 cfs @ 3.38 fps)

Secondary OutFlow Max=1.18 cfs @ 12.13 hrs HW=11.83' (Free Discharge)
 ↳2=LARGE STORM OVERFLOW(Orifice Controls 1.18 cfs @ 2.69 fps)

14850_Proposed-Drainage-Areas_220609

NOAA 24-hr C NOAA 25-yr Rainfall=6.04"

Prepared by {enter your company name here}

Printed 6/16/2022

HydroCAD® 10.10-7a s/n 00546 © 2021 HydroCAD Software Solutions LLC

Page 154

Summary for Pond INF-1: INFILTRATION SYSTEM #1

[81] Warning: Exceeded Pond DMH1 by 0.24' @ 15.20 hrs

Inflow Area = 19,582 sf, 58.17% Impervious, Inflow Depth = 3.45" for NOAA 25-yr event
 Inflow = 0.78 cfs @ 12.13 hrs, Volume= 5,625 cf
 Outflow = 0.45 cfs @ 12.37 hrs, Volume= 5,625 cf, Atten= 42%, Lag= 14.5 min
 Discarded = 0.08 cfs @ 12.37 hrs, Volume= 4,624 cf
 Primary = 0.37 cfs @ 12.37 hrs, Volume= 1,001 cf
 Routed to Reach DP-1 : French Rodney Blvd Outfall

Routing by Stor-Ind method, Time Span= 0.00-72.00 hrs, dt= 0.05 hrs
 Peak Elev= 9.48' @ 12.37 hrs Surf.Area= 1,772 sf Storage= 1,689 cf

Plug-Flow detention time= 201.8 min calculated for 5,621 cf (100% of inflow)
 Center-of-Mass det. time= 201.8 min (1,018.7 - 816.9)

Volume	Invert	Avail.Storage	Storage Description
#1A	7.80'	1,091 cf	21.50'W x 81.52'L x 2.33'H Field A 4,090 cf Overall - 973 cf Embedded = 3,117 cf x 35.0% Voids
#2A	8.30'	973 cf	ADS StormTech SC-310 +Cap x 66 Inside #1 Effective Size= 28.9"W x 16.0"H => 2.07 sf x 7.12'L = 14.7 cf Overall Size= 34.0"W x 16.0"H x 7.56'L with 0.44' Overlap 66 Chambers in 6 Rows
#3	7.80'	137 cf	5.00'D x 7.00'H Vertical Cone/Cylinder
		2,201 cf	Total Available Storage

Storage Group A created with Chamber Wizard

Device	Routing	Invert	Outlet Devices
#1	Discarded	7.80'	1.020 in/hr Exfiltration over Surface area Conductivity to Groundwater Elevation = 5.80'
#2	Primary	8.10'	10.0" Round Culvert L= 10.0' CPP, square edge headwall, Ke= 0.500 Inlet / Outlet Invert= 8.10' / 8.00' S= 0.0100 '/' Cc= 0.900 n= 0.012 Corrugated PP, smooth interior, Flow Area= 0.55 sf
#3	Device 2	9.40'	5.0' long Sharp-Crested Rectangular Weir 2 End Contraction(s)

Discarded OutFlow Max=0.08 cfs @ 12.37 hrs HW=9.48' (Free Discharge)
 ↳1=Exfiltration (Controls 0.08 cfs)

Primary OutFlow Max=0.36 cfs @ 12.37 hrs HW=9.48' (Free Discharge)
 ↳2=Culvert (Passes 0.36 cfs of 2.58 cfs potential flow)
 ↳3=Sharp-Crested Rectangular Weir(Weir Controls 0.36 cfs @ 0.92 fps)

14850_Proposed-Drainage-Areas_220609

NOAA 24-hr C NOAA 25-yr Rainfall=6.04"

Prepared by {enter your company name here}

Printed 6/16/2022

HydroCAD® 10.10-7a s/n 00546 © 2021 HydroCAD Software Solutions LLC

Page 155

Pond INF-1: INFILTRATION SYSTEM #1 - Chamber Wizard Field A

Chamber Model = ADS_StormTechSC-310+Cap (ADS StormTech®SC-310 with cap length)

Effective Size= 28.9"W x 16.0"H => 2.07 sf x 7.12'L = 14.7 cf

Overall Size= 34.0"W x 16.0"H x 7.56'L with 0.44' Overlap

34.0" Wide + 6.0" Spacing = 40.0" C-C Row Spacing

11 Chambers/Row x 7.12' Long +0.60' Cap Length x 2 = 79.52' Row Length +12.0" End Stone x 2 = 81.52' Base Length

6 Rows x 34.0" Wide + 6.0" Spacing x 5 + 12.0" Side Stone x 2 = 21.50' Base Width

6.0" Stone Base + 16.0" Chamber Height + 6.0" Stone Cover = 2.33' Field Height

66 Chambers x 14.7 cf = 973.0 cf Chamber Storage

4,089.6 cf Field - 973.0 cf Chambers = 3,116.6 cf Stone x 35.0% Voids = 1,090.8 cf Stone Storage

Chamber Storage + Stone Storage = 2,063.8 cf = 0.047 af

Overall Storage Efficiency = 50.5%

Overall System Size = 81.52' x 21.50' x 2.33'

66 Chambers
151.5 cy Field
115.4 cy Stone

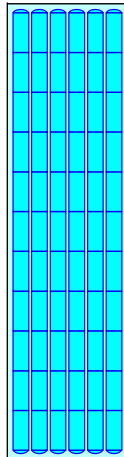

14850_Proposed-Drainage-Areas_220609

NOAA 24-hr C NOAA 25-yr Rainfall=6.04"

Prepared by {enter your company name here}

Printed 6/16/2022

HydroCAD® 10.10-7a s/n 00546 © 2021 HydroCAD Software Solutions LLC

Page 156

Summary for Pond INF-2: INFILTRATION SYSTEM #2

Inflow Area = 143,309 sf, 49.69% Impervious, Inflow Depth = 2.38" for NOAA 25-yr event

Inflow = 3.65 cfs @ 12.13 hrs, Volume= 28,364 cf

Outflow = 3.30 cfs @ 12.17 hrs, Volume= 28,364 cf, Atten= 10%, Lag= 2.4 min

Discarded = 0.12 cfs @ 12.16 hrs, Volume= 9,579 cf

Primary = 3.18 cfs @ 12.17 hrs, Volume= 18,785 cf

Routed to Reach B : PARKING LOT B OVERFLOW

Routing by Stor-Ind method, Time Span= 0.00-72.00 hrs, dt= 0.05 hrs

Peak Elev= 9.87' @ 12.16 hrs Surf.Area= 2,268 sf Storage= 3,518 cf

Plug-Flow detention time= 125.5 min calculated for 28,344 cf (100% of inflow)

Center-of-Mass det. time= 125.9 min (984.2 - 858.3)

Volume	Invert	Avail.Storage	Storage Description
#1A	7.50'	1,790 cf	25.25'W x 89.06'L x 3.50'H Field A 7,870 cf Overall - 2,756 cf Embedded = 5,114 cf x 35.0% Voids
#2A	8.00'	2,756 cf	ADS_StormTech SC-740 +Cap x 60 Inside #1 Effective Size= 44.6"W x 30.0"H => 6.45 sf x 7.12'L = 45.9 cf Overall Size= 51.0"W x 30.0"H x 7.56'L with 0.44' Overlap 60 Chambers in 5 Rows
#3	7.50'	137 cf	5.00'D x 7.00'H Vertical Cone/Cylinder
		4,684 cf	Total Available Storage

Storage Group A created with Chamber Wizard

Device	Routing	Invert	Outlet Devices
#1	Discarded	7.50'	1.020 in/hr Exfiltration over Surface area Conductivity to Groundwater Elevation = 5.50'
#2	Primary	8.00'	10.0" Round Culvert L= 10.0' CPP, square edge headwall, Ke= 0.500 Inlet / Outlet Invert= 8.00' / 7.90' S= 0.0100'/' Cc= 0.900 n= 0.012 Corrugated PP, smooth interior, Flow Area= 0.55 sf
#3	Device 2	9.50'	5.0' long Sharp-Crested Rectangular Weir 2 End Contraction(s)

Discarded OutFlow Max=0.12 cfs @ 12.16 hrs HW=9.86' (Free Discharge)

↳ **1=Exfiltration** (Controls 0.12 cfs)

Primary OutFlow Max=3.15 cfs @ 12.17 hrs HW=9.85' (Free Discharge)

↳ **2=Culvert** (Inlet Controls 3.15 cfs @ 5.77 fps)

↳ **3=Sharp-Crested Rectangular Weir** (Passes 3.15 cfs of 3.39 cfs potential flow)

14850_Proposed-Drainage-Areas_220609

NOAA 24-hr C NOAA 25-yr Rainfall=6.04"

Prepared by {enter your company name here}

Printed 6/16/2022

HydroCAD® 10.10-7a s/n 00546 © 2021 HydroCAD Software Solutions LLC

Page 157

Pond INF-2: INFILTRATION SYSTEM #2 - Chamber Wizard Field A

Chamber Model = ADS_StormTechSC-740+Cap (ADS StormTech®SC-740 with cap length)

Effective Size= 44.6"W x 30.0"H => 6.45 sf x 7.12'L = 45.9 cf

Overall Size= 51.0"W x 30.0"H x 7.56'L with 0.44' Overlap

51.0" Wide + 6.0" Spacing = 57.0" C-C Row Spacing

12 Chambers/Row x 7.12' Long +0.81' Cap Length x 2 = 87.06' Row Length +12.0" End Stone x 2 = 89.06' Base Length

5 Rows x 51.0" Wide + 6.0" Spacing x 4 + 12.0" Side Stone x 2 = 25.25' Base Width

6.0" Stone Base + 30.0" Chamber Height + 6.0" Stone Cover = 3.50' Field Height

60 Chambers x 45.9 cf = 2,756.4 cf Chamber Storage

7,870.4 cf Field - 2,756.4 cf Chambers = 5,114.0 cf Stone x 35.0% Voids = 1,789.9 cf Stone Storage

Chamber Storage + Stone Storage = 4,546.3 cf = 0.104 af

Overall Storage Efficiency = 57.8%

Overall System Size = 89.06' x 25.25' x 3.50'

60 Chambers
291.5 cy Field
189.4 cy Stone

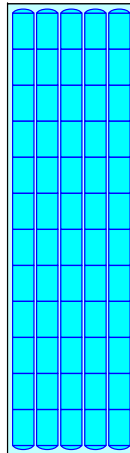

14850_Proposed-Drainage-Areas_220609

NOAA 24-hr C NOAA 25-yr Rainfall=6.04"

Prepared by {enter your company name here}

Printed 6/16/2022

HydroCAD® 10.10-7a s/n 00546 © 2021 HydroCAD Software Solutions LLC

Page 158

Summary for Pond INF3: INFILTRATION SYSTEM #1

Inflow Area = 19,743 sf, 50.83% Impervious, Inflow Depth = 3.66" for NOAA 25-yr event

Inflow = 1.21 cfs @ 12.13 hrs, Volume= 6,020 cf

Outflow = 1.20 cfs @ 12.14 hrs, Volume= 6,020 cf, Atten= 1%, Lag= 0.9 min

Discarded = 0.05 cfs @ 12.14 hrs, Volume= 3,178 cf

Primary = 1.15 cfs @ 12.14 hrs, Volume= 2,842 cf

Routed to Reach P ST : PORTLAND STREET DRAINAGE

Routing by Stor-Ind method, Time Span= 0.00-72.00 hrs, dt= 0.05 hrs

Peak Elev= 9.67' @ 12.14 hrs Surf.Area= 1,113 sf Storage= 1,000 cf

Plug-Flow detention time= 132.5 min calculated for 6,016 cf (100% of inflow)

Center-of-Mass det. time= 132.7 min (948.3 - 815.6)

Volume	Invert	Avail.Storage	Storage Description
#1A	8.10'	686 cf	18.17'W x 60.16'L x 2.33'H Field A 2,550 cf Overall - 590 cf Embedded = 1,960 cf x 35.0% Voids
#2A	8.60'	590 cf	ADS_StormTech SC-310 +Cap x 40 Inside #1 Effective Size= 28.9"W x 16.0"H => 2.07 sf x 7.12'L = 14.7 cf Overall Size= 34.0"W x 16.0"H x 7.56'L with 0.44' Overlap 40 Chambers in 5 Rows
#3	8.10'	137 cf	5.00'D x 7.00'H Vertical Cone/Cylinder
		1,413 cf	Total Available Storage

Storage Group A created with Chamber Wizard

Device	Routing	Invert	Outlet Devices
#1	Discarded	8.10'	1.020 in/hr Exfiltration over Surface area Conductivity to Groundwater Elevation = 6.10'
#2	Primary	8.40'	10.0" Round Culvert L= 10.0' CPP, square edge headwall, Ke= 0.500 Inlet / Outlet Invert= 8.40' / 8.30' S= 0.0100'/' Cc= 0.900 n= 0.012 Corrugated PP, smooth interior, Flow Area= 0.55 sf
#3	Device 2	9.50'	5.0' long Sharp-Crested Rectangular Weir 2 End Contraction(s)

Discarded OutFlow Max=0.05 cfs @ 12.14 hrs HW=9.67' (Free Discharge)

↳ **1=Exfiltration** (Controls 0.05 cfs)

Primary OutFlow Max=1.13 cfs @ 12.14 hrs HW=9.67' (Free Discharge)

↳ **2=Culvert** (Passes 1.13 cfs of 2.36 cfs potential flow)

↳ **3=Sharp-Crested Rectangular Weir**(Weir Controls 1.13 cfs @ 1.34 fps)

Pond INF3: INFILTRATION SYSTEM #1 - Chamber Wizard Field A

Chamber Model = ADS_StormTechSC-310+Cap (ADS StormTech®SC-310 with cap length)

Effective Size= 28.9"W x 16.0"H => 2.07 sf x 7.12'L = 14.7 cf

Overall Size= 34.0"W x 16.0"H x 7.56'L with 0.44' Overlap

34.0" Wide + 6.0" Spacing = 40.0" C-C Row Spacing

8 Chambers/Row x 7.12' Long +0.60' Cap Length x 2 = 58.16' Row Length +12.0" End Stone x 2 = 60.16' Base Length

5 Rows x 34.0" Wide + 6.0" Spacing x 4 + 12.0" Side Stone x 2 = 18.17' Base Width

6.0" Stone Base + 16.0" Chamber Height + 6.0" Stone Cover = 2.33' Field Height

40 Chambers x 14.7 cf = 589.7 cf Chamber Storage

2,550.1 cf Field - 589.7 cf Chambers = 1,960.4 cf Stone x 35.0% Voids = 686.2 cf Stone Storage

Chamber Storage + Stone Storage = 1,275.8 cf = 0.029 af

Overall Storage Efficiency = 50.0%

Overall System Size = 60.16' x 18.17' x 2.33'

40 Chambers
94.4 cy Field
72.6 cy Stone

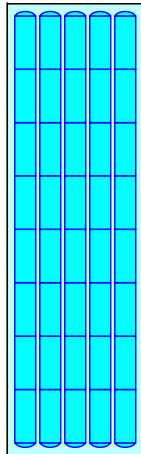

APPENDIX E

Long-Term Pollution Prevention and Stormwater Operation and Maintenance Plan

LONG-TERM POLLUTION PREVENTION PLAN AND STORMWATER OPERATION AND MAINTENANCE PLAN

East Beach, New Bedford, MA

TABLE OF CONTENTS

1.0 INTRODUCTION	1
2.0 LONG-TERM POLLUTION PREVENTION PLAN	2
2.1 Storage of Hazardous Materials	2
2.2 Storage of Waste Products	2
2.3 Spill Prevention and Response	2
2.4 Minimize Soil Erosion	2
2.5 Maintenance of Lawns, Gardens, and other Landscaped Areas	2
2.6 Management of Deicing Chemicals and Snow	3
2.7 Coordination with other Permits and Requirements	3
3.0 STORMWATER MANAGEMENT SYSTEM OPERATION AND MAINTENANCE PLAN	3
3.1 Introduction	3
3.2 Stormwater Operation and Maintenance Requirements	4
Deep Sump and Hooded Catch Basins	4
Area Drains	4
Isolator Row	4
Subsurface Infiltration Structures	4
Bioretention Areas	4
3.3 Repair of the Stormwater Management System	5
3.4 Reporting	5
STORMWATER MANAGEMENT SYSTEM INSPECTION FORM.....	1
 ATTACHMENT A – ISOLATOR ROW MAINTENANCE MANUAL	

1.0 INTRODUCTION

The purpose of this document is to specify the pollution prevention measures and stormwater management system operation and maintenance for the East Beach site. The Responsible Party indicated below shall implement the management practices outlined in this document and proactively conduct operations at the project site in an environmentally responsible manner. Compliance with this Manual does not in any way dismiss the responsible party, owner, property manager, or occupants from compliance with other applicable federal, state or local laws.

Responsible Party: City of New Bedford

This Document has been prepared in compliance with Standards 4 and 9 of the 2008 Massachusetts Department of Environmental Protection (MassDEP) Stormwater Management Standards, which state:

Standard 4:

The Long Term Pollution Prevention Plan shall include the proper procedures for the following:

- Good housekeeping
- Storing materials and waste products inside or under cover
- Vehicle washing
- Routine inspections of stormwater best management practices
- Spill prevention and response
- Maintenance of lawns, gardens, and other landscaped areas
- Storage and use of slow-release phosphorous free fertilizer
- Prohibition of herbicides, fungicides and pesticides
- Pet waste management
- Operation and management of septic systems
- Proper management of deicing chemicals and snow

Standard 9:

The Long-Term Operation and Maintenance Plan shall at a minimum include:

- Stormwater management system(s) owner(s)
- The party or parties responsible for operation and maintenance, including how future property owners shall be notified of the presence of the stormwater management system and the requirement for operation and maintenance
- The routine and non-routine maintenance tasks to be undertaken after construction is complete and a schedule for implementing those tasks
- A plan that is drawn to scale and shows the location of all stormwater BMPs in each treatment train along with the discharge point
- A description and delineation of public safety features
- An estimated operations and maintenance budget

2.0 LONG-TERM POLLUTION PREVENTION PLAN

The Responsible Party shall implement the following good housekeeping procedures at the project site to reduce the possibility of accidental releases and to reduce safety hazards.

2.1 Storage of Hazardous Materials

To prevent leaks and spills, keep hazardous materials and waste products under cover or inside. Use drip pans or spill containment systems to prevent chemicals from entering the drainage system. Inspect storage areas for materials and waste products at least once per year to determine amount and type of the material on site, and if the material requires disposal.

Securely store liquid petroleum products and other liquid chemicals in federally- and state-approved containers. Restrict access to maintenance personnel and administrators.

2.2 Storage of Waste Products

Collect and store all waste materials in securely lidded dumpster(s) or other secure containers as applicable to the material. Keep dumpster lids closed and the areas around them clean. Do not fill the dumpsters with liquid waste or hose them out. Sweep areas around the dumpster regularly and put the debris in the garbage, instead of sweeping or hosing it into the parking lot. Legally dispose of collected waste on a regular basis.

Segregate liquid wastes from solid waste and recycle through hazardous waste disposal companies, whenever possible. Contact a hazardous waste hauler for proper disposal to a hazardous waste collection center.

2.3 Spill Prevention and Response

Implement spill response procedures for releases of significant materials such as fuels, oils, or chemical materials onto the ground or other area that could reasonably be expected to discharge to surface or groundwater.

- For minor spills, keep fifty (50) gallon spill control kits and Speedy Dry at all shop and work areas.
- Immediately contact applicable Federal, State, and local agencies for reportable quantities as required by law.
- Immediately perform applicable containment and cleanup procedures following a spill release.
- Promptly remove and dispose of all material collected during the response in accordance with Federal, State and local requirements. A licensed emergency response contractor may be required to assist in cleanup of releases depending on the amount of the release, and the ability of the Contractor to perform the required response.
- Reportable quantities of chemicals, fuels, or oils are established under the Clean Water Act and enforced through Massachusetts Department of Environmental Protection (DEP).

2.4 Minimize Soil Erosion

Soil erosion facilitates mechanical transport of nutrients, pathogens, and organic matter to surface water bodies. Repair all areas where erosion is occurring throughout the project site. Stabilize bare soil with riprap, seed, mulch, or vegetation.

2.5 Maintenance of Lawns, Gardens, and other Landscaped Areas

Pesticides, herbicide and fungicide shall not be used in the landscaped areas associated with the

project site and shall not be stored on-site. Slow-release, phosphorus free fertilizer is allowed. Dumping of lawn wastes, brush or leaves or other materials or debris is not permitted in any Resource Area. Grass clippings pruned branches and any other landscaped waste should be disposed of or composted in an appropriate location. No irrigation shall be used in the landscaped areas for this project.

2.6 Management of Deicing Chemicals and Snow

The qualified contractor selected for snow plowing and deicing shall be made fully aware of the requirements of this section.

No road salt (sodium chloride) shall be stored on-site. The use of magnesium chloride de-icing product with a 0.5 to 1.0 percent sodium chloride mix for snow and ice treatment is permitted. The product shall be stored in a locked room inside the building and shall be used at exterior stairs and walkways. The snow plow contractor shall adhere to these magnesium chloride use and storage requirements.

Snow shall not be stockpiled in the riverfront area or the 100-foot Buffer Zone, catch basins, or area drains. In severe conditions where snow cannot be stockpiled on site, the snow shall be removed from the site and properly disposed of in accordance with DEP Guideline BRP601-01.

Before winter begins, the property owner and the contractor shall review snow plowing, deicing, and stockpiling procedures. Areas designated for stockpiling should be cleaned of any debris. Street and parking lot sweeping should be followed in accordance with the Operation and Maintenance Plan.

2.7 Coordination with other Permits and Requirements

Certain conditions of other approvals affecting the long term management of the property shall be considered part of this Long Term Pollution Prevention Plan. The Owner shall become familiar with those documents and comply with the guidelines set forth in those documents.

3.0 STORMWATER MANAGEMENT SYSTEM OPERATION AND MAINTENANCE PLAN

3.1 Introduction

This Operation and Maintenance Plan (O&M Plan) for East Beach site is required under Standard 9 of the 2008 MassDEP Stormwater Handbook to provide best management practices for implementing maintenance activities for the stormwater management system in a manner that minimizes impacts to wetland resource areas.

The Owner shall implement this O&M Plan and proactively conduct operations at the site in an environmentally responsible manner. Compliance with this O&M Plan does not in any way dismiss the Owner from compliance with other applicable Federal, State or local laws.

Routine maintenance during construction and post-development phases of the project, as defined in the Operation and Maintenance Plan, shall be permitted without amendment to the Order of Conditions. A continuing condition in the Certificate of Compliance shall ensure that maintenance can be performed without triggering further filings under the Wetlands Protection Act.

All stormwater best management practices (BMPs) shall be operated and maintained in accordance with the design plans and the Operation and Maintenance Plan approved by the issuing authority. The Owner shall:

- a. Maintain an operation and maintenance log for the last three years, including inspections, repairs, replacement and disposal (for disposal the log shall indicate the type of material and

the disposal location). This is a rolling log in which the responsible party records all operation and maintenance activities for the past three years.

- b. Make this log available to MassDEP and the Conservation Commission upon request; and
- c. Allow members and agents of the MassDEP and the Conservation Commission to enter and inspect the premises to evaluate and ensure that the Owner complies with the Operation and Maintenance requirements for each BMP.

3.2 Stormwater Operation and Maintenance Requirements

Inspect and maintain the stormwater management system as directed below. Refer to the Stormwater Management System Location Map (Figure 1) for the location of each component of the system. Repairs to any component of the system shall be made as soon as possible to prevent any potential pollutants (including silt) from entering the resource areas.

Deep Sump and Hooded Catch Basins

Inspect or clean catch basins four times per year and at the end of foliage and snow-removal seasons. Other inspection and maintenance requirements include:

- Remove organic material, sediment and hydrocarbons four times per year or whenever the depth of deposits is greater than or equal to one half the depth from the bottom of the invert of the lowest pipe in the basin.
- Always clean out catch basins after street sweeping. If any evidence of hydrocarbons is found during inspection, immediately remove the material using absorbent pads or other suitable measures and dispose of legally. Remove other accumulated debris as necessary.
- If handling runoff from land uses with higher potential pollutant loads or discharging runoff near or to a critical area, more frequent cleaning may be necessary.
- Transport and disposal of accumulated sediment off-site shall be in accordance with applicable local, state and federal guidelines and regulations.

Area Drains

Inspect area drains at least once per month and remove debris from the grate. Clean out accumulated sediments at least once per year and more frequently as necessary.

Isolator Row

Maintain water quality units according the recommendations set forth by the manufacturer. Refer to the Isolator Row O&M Manual, provided as Attachment A.

Subsurface Infiltration Structures

Inspect subsurface detention/infiltration structures twice per year. Inspect the inlets and observation ports to determine if there is accumulated sediment within the system. Remove all debris and accumulated sediment that may clog the system.

Bioretention Areas

Perform annual maintenance of all components of the bioretention area, including plants, soil, and mulch. Table 1, below, outlines recommended maintenance activities.

Table 1. Bioretention area maintenance recommendations

Location	Description	Frequency	Time of Year
Surface	Inspect and remove trash	Monthly	Year round
Soil	Inspect and repair erosion	Monthly	Year round
Organic Layer	Remulch void areas	Annually	Spring
	Remove previous mulch layer before applying new layer (optional)	Annually	Spring
Plants	Water vegetation at end of day for 14 consecutive days after planting	Immediately after planting	As needed
	Fertilize	Annually	Spring
	Mow grass	2 to 12 times per year	As needed
	Remove and replace all dead and diseased vegetation that cannot be treated	Annually	Spring
	Treat all diseased trees and shrubs	As needed	Variable

During and after storm events, record the length of time standing water remains in the bioretention areas. If the time is greater than 72 hours, thoroughly inspect the basins for signs of clogging and develop a corrective action plan. The corrective action plan, prepared by a qualified professional, will outline procedures to restore infiltrative function. The owner of the site shall take immediate action to implement these corrective measures. Inspect pretreatment devices and bioretention cells regularly for sediment build-up, structural damage, and standing water. Never store snow in bioretention areas.

3.3 Repair of the Stormwater Management System

The stormwater management system shall be maintained. The repair of any component of the system shall be made as soon as possible to prevent any potential pollutants including silt from entering the resource areas or the existing closed drainage system.

3.4 Reporting

The City shall maintain a record of drainage system inspections and maintenance (per this Plan) and submit a yearly report to the New Bedford Conservation Commission.

STORMWATER MANAGEMENT SYSTEM INSPECTION FORM

East Beach New Bedford, MA		Inspected by: _____ Date: _____
Component	Status/Inspection	Action Taken
Deep Sump Catch Basins, Area Drains and Drain Manholes		
Subsurface Infiltration System		
Bioretention Basins		
Isolator Row		
General site conditions – evidence of erosion, etc.		

SUBMIT COPIES OF STORMWATER MANAGEMENT SYSTEM INSPECTION FORM TO THE NEW BEDFORD CONSERVATION COMMISSION WITH THE YEARLY REPORT

Isolator[®] Row Plus

O&M Manual



The Isolator[®] Row Plus

Introduction

An important component of any Stormwater Pollution Prevention Plan is inspection and maintenance. The StormTech Isolator Row Plus is a technique to inexpensively enhance Total Suspended Solids (TSS) and Total Phosphorus (TP) removal with easy access for inspection and maintenance.

The Isolator Row Plus

The Isolator Row Plus is a row of StormTech chambers, either SC-160, SC-310, SC-310-3, SC-740, DC-780, MC-3500 or MC-7200 models, that is surrounded with filter fabric and connected to a closely located manhole for easy access. The fabric-wrapped chambers provide for sediment settling and filtration as stormwater rises in the Isolator Row Plus and passes through the filter fabric. The open bottom chambers and perforated sidewalls (SC-310, SC-310-3 and SC-740 models) allow stormwater to flow both vertically and horizontally out of the chambers. Sediments are captured in the Isolator Row Plus protecting the adjacent stone and chambers storage areas from sediment accumulation.

ADS geotextile fabric is placed between the stone and the Isolator Row Plus chambers. The woven geotextile provides a media for stormwater filtration, a durable surface for maintenance, prevents scour of the underlying stone and remains intact during high pressure jetting. A non-woven fabric is placed over the chambers to provide a filter media for flows passing through the chamber's sidewall. The non-woven fabric is not required over the SC-160, DC-780, MC-3500 or MC-7200 models as these chambers do not have perforated side walls.

The Isolator Row Plus is designed to capture the "first flush" runoff and offers the versatility to be sized on a volume basis or a flow-rate basis. An upstream manhole provides access to the Isolator Row Plus and includes a high/low concept such that stormwater flow rates or volumes that exceed the capacity of the Isolator Row Plus bypass through a manifold to the other chambers. This is achieved with an elevated bypass manifold or a high-flow weir. This creates a differential between the Isolator Row Plus row of chambers and the manifold to the rest of the system, thus allowing for settlement time in the Isolator Row Plus. After Stormwater flows through the Isolator Row Plus and into the rest of the chamber system it is either exfiltrated into the soils below or passed at a controlled rate through an outlet manifold and outlet control structure.

The Isolator Row FLAMP[™] (patent pending) is a flared end ramp apparatus attached to the inlet pipe on the inside of the chamber end cap. The FLAMP provides a smooth transition from pipe invert to fabric bottom. It is configured to improve chamber function performance by enhancing outflow of solid debris that would otherwise collect at the chamber's end. It also serves to improve the fluid and solid flow into the access pipe during maintenance and cleaning and to guide cleaning and inspection equipment back into the inlet pipe when complete.

The Isolator Row Plus may be part of a treatment train system. The treatment train design and pretreatment device selection by the design engineer is often driven by regulatory requirements. Whether pretreatment is used or not, StormTech recommend using the Isolator Row Plus to minimize maintenance requirements and maintenance costs.

Note: See the StormTech Design Manual for detailed information on designing inlets for a StormTech system, including the Isolator Row Plus.



Looking down the Isolator Row PLUS from the manhole opening, ADS PLUS Fabric is shown between the chamber and stone base.



StormTech Isolator Row PLUS with Overflow Spillway (not to scale)

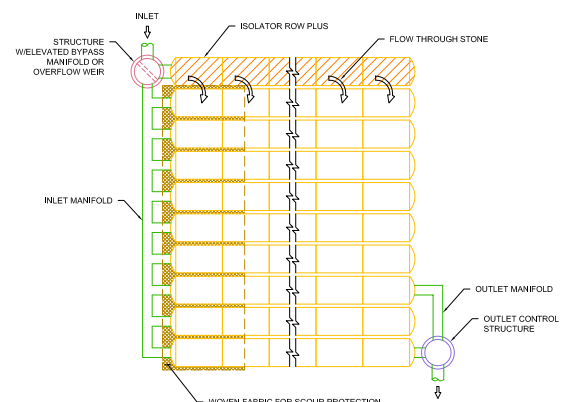

Isolator Row Plus Inspection/Maintenance

Inspection

The frequency of inspection and maintenance varies by location. A routine inspection schedule needs to be established for each individual location based upon site specific variables. The type of land use (i.e. industrial, commercial, residential), anticipated pollutant load, percent imperviousness, climate, etc. all play a critical role in determining the actual frequency of inspection and maintenance practices.

At a minimum, StormTech recommends annual inspections. Initially, the Isolator Row Plus should be inspected every 6 months for the first year of operation. For subsequent years, the inspection should be adjusted based upon previous observation of sediment deposition.

The Isolator Row Plus incorporates a combination of standard manhole(s) and strategically located inspection ports (as needed). The inspection ports allow for easy access to the system from the surface, eliminating the need to perform a confined space entry for inspection purposes.

If upon visual inspection it is found that sediment has accumulated, a stadia rod should be inserted to determine the depth of sediment. When the average depth of sediment exceeds 3 inches throughout the length of the Isolator Row Plus, clean-out should be performed.

Maintenance

The Isolator Row Plus was designed to reduce the cost of periodic maintenance. By "isolating" sediments to just one row, costs are dramatically reduced by eliminating the need to clean out each row of the entire storage bed. If inspection indicates the potential need for maintenance, access is provided

via a manhole(s) located on the end(s) of the row for cleanout. If entry into the manhole is required, please follow local and OSHA rules for a confined space entries.

Maintenance is accomplished with the JetVac process. The JetVac process utilizes a high pressure water nozzle to propel itself down the Isolator Row Plus while scouring and suspending sediments. As the nozzle is retrieved, the captured pollutants are flushed back into the manhole for vacuuming. Most sewer and pipe maintenance companies have vacuum/JetVac combination vehicles. Selection of an appropriate JetVac nozzle will improve maintenance efficiency. Fixed nozzles designed for culverts or large diameter pipe cleaning are preferable. Rear facing jets with an effective spread of at least 45" are best. StormTech recommends a maximum nozzle pressure of 2000 psi be utilized during cleaning. JetVac reels can vary in length. For ease of maintenance, ADS recommends Isolator Row Plus lengths up to 200' (61 m). **The JetVac process shall only be performed on StormTech Isolator Row Plus that have ADS Plus Fabric (as specified by StormTech) over their angular base stone.**

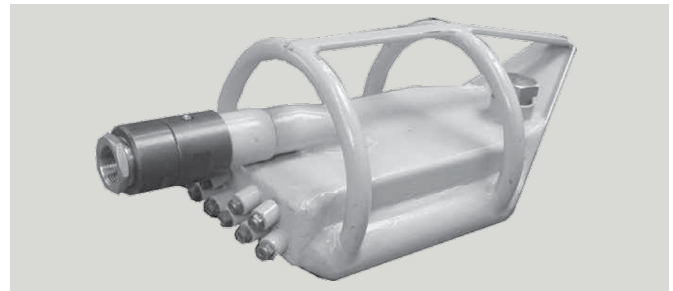

StormTech Isolator Row PLUS (not to scale)

Note: Non-woven fabric is only required over the inlet pipe connection into the end cap for SC-160LP, DC-780, MC-3500 and MC-7200 chamber models and is not required over the entire Isolator Row PLUS.

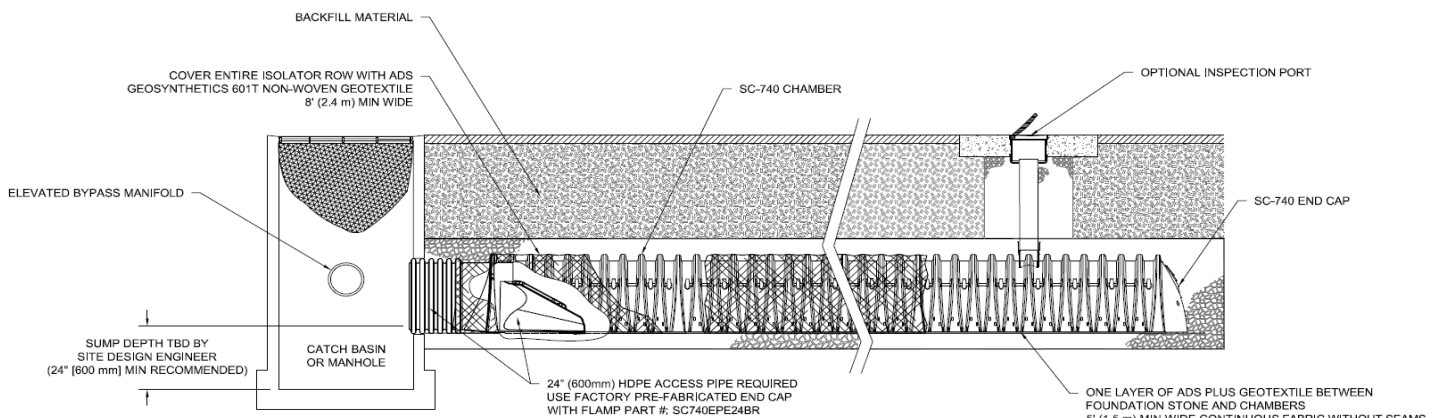

Isolator Row Plus Step By Step Maintenance Procedures

Step 1

Inspect Isolator Row Plus for sediment.

- A) Inspection ports (if present)
 - i. Remove lid from floor box frame
 - ii. Remove cap from inspection riser
 - iii. Using a flashlight and stadia rod, measure depth of sediment and record results on maintenance log.
 - iv. If sediment is at or above 3 inch depth, proceed to Step 2. If not, proceed to Step 3.
- B) All Isolator Row Plus
 - i. Remove cover from manhole at upstream end of Isolator Row Plus
 - ii. Using a flashlight, inspect down Isolator Row Plus through outlet pipe
 - 1. Mirrors on poles or cameras may be used to avoid a confined space entry
 - 2. Follow OSHA regulations for confined space entry if entering manhole
 - iii. If sediment is at or above the lower row of sidewall holes (approximately 3 inches), proceed to Step 2. If not, proceed to Step 3.

Step 2

Clean out Isolator Row Plus using the JetVac process.

- A) A fixed floor cleaning nozzle with rear facing nozzle spread of 45 inches or more is preferable
- B) Apply multiple passes of JetVac until backflush water is clean
- C) Vacuum manhole sump as required

Step 3

Replace all caps, lids and covers, record observations and actions.

Step 4

Inspect & clean catch basins and manholes upstream of the StormTech system.

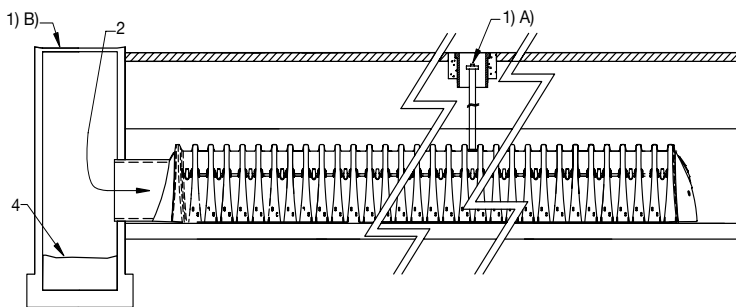

Sample Maintenance Log

Date	Stadia Rod Readings		Sedi-ment Depth (1)-(2)	Observations/Actions	Inspector
	Fixed point to chamber bottom (1)	Fixed point to top of sediment (2)			
3/15/11	6.3 ft	none		New installation. Fixed point is CI frame at grade	DJM
9/24/11		6.2	0.1 ft	Some grit felt	SM
6/20/13		5.8	0.5 ft	Mucky feel, debris visible in manhole and in Isolator Row PLUS, maintenance due	NV
7/7/13	6.3 ft		0	System jetted and vacuumed	DJM

adspipe.com

800-821-6710

APPENDIX F

Soil Investigations

NRCS Soil Maps and Descriptions
Soil Test Pit Logs

Hydrologic Soil Group—Bristol County, Massachusetts, Southern Part

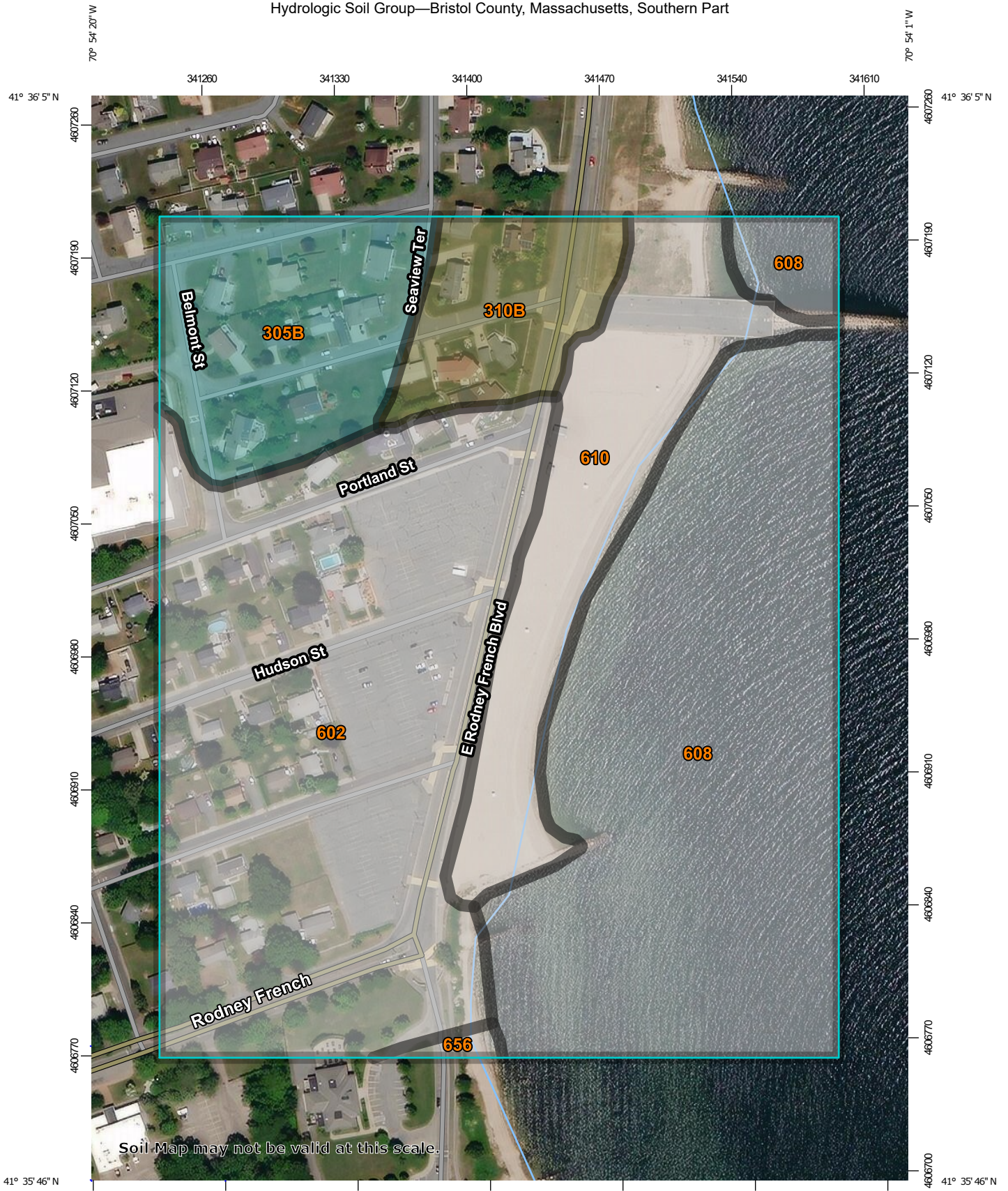

Soil Map may not be valid at this scale.

Map Scale: 1:2,780 if printed on A portrait (8.5" x 11") sheet.

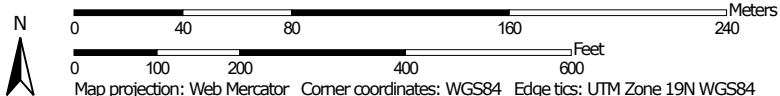

Map projection: Web Mercator Corner coordinates: WGS84 Edge tics: UTM Zone 19N WGS84



MAP LEGEND

Area of Interest (AOI)

 Area of Interest (AOI)

Soils

Soil Rating Polygons

 A
 A/D
 B
 B/D
 C
 C/D
 D
 Not rated or not available

Soil Rating Lines

 A
 A/D
 B
 B/D
 C
 C/D
 D
 Not rated or not available

Soil Rating Points

 A
 A/D
 B
 B/D

 C
 C/D
 D
 Not rated or not available

Water Features

 Streams and Canals

Transportation

 Rails
 Interstate Highways
 US Routes
 Major Roads
 Local Roads

Background

 Aerial Photography

MAP INFORMATION

The soil surveys that comprise your AOI were mapped at 1:20,000.

Warning: Soil Map may not be valid at this scale.

Enlargement of maps beyond the scale of mapping can cause misunderstanding of the detail of mapping and accuracy of soil line placement. The maps do not show the small areas of contrasting soils that could have been shown at a more detailed scale.

Please rely on the bar scale on each map sheet for map measurements.

Source of Map: Natural Resources Conservation Service
 Web Soil Survey URL:
 Coordinate System: Web Mercator (EPSG:3857)

Maps from the Web Soil Survey are based on the Web Mercator projection, which preserves direction and shape but distorts distance and area. A projection that preserves area, such as the Albers equal-area conic projection, should be used if more accurate calculations of distance or area are required.

This product is generated from the USDA-NRCS certified data as of the version date(s) listed below.

Soil Survey Area: Bristol County, Massachusetts, Southern Part
 Survey Area Data: Version 15, Sep 2, 2021

Soil map units are labeled (as space allows) for map scales 1:50,000 or larger.

Date(s) aerial images were photographed: Dec 31, 2009—Oct 15, 2020

The orthophoto or other base map on which the soil lines were compiled and digitized probably differs from the background imagery displayed on these maps. As a result, some minor shifting of map unit boundaries may be evident.

Hydrologic Soil Group

Map unit symbol	Map unit name	Rating	Acres in AOI	Percent of AOI
305B	Paxton fine sandy loam, 3 to 8 percent slopes	C	4.1	10.5%
310B	Woodbridge fine sandy loam, 3 to 8 percent slopes	C/D	2.4	6.2%
602	Urban land		14.1	35.8%
608	Water, ocean		13.7	34.7%
610	Beaches, sand		4.9	12.4%
656	Udorthents - Urban land complex		0.2	0.4%
Totals for Area of Interest			39.4	100.0%



Form 11 - Soil Suitability Assessment for On-Site Sewage Disposal

C. On-Site Review *(minimum of two holes required at every proposed primary and reserve disposal area)*

Deep Observation Hole Number: 1 2/24/2022 9:15 30/cloudy
Hole # Date Time Weather Latitude Longitude:

1. Land Use Parking Lot - - -
(e.g., woodland, agricultural field, vacant lot, etc.) Vegetation Surface Stones (e.g., cobbles, stones, boulders, etc.) Slope (%)
 Description of Location: Southern parking lot

2. Soil Parent Material: - - -
Landform Position on Landscape (SU, SH, BS, FS, TS)

3. Distances from: Open Water Body 150' feet Drainage Way - feet Wetlands - feet
 Property Line - feet Drinking Water Well - feet Other - feet

4. Unsuitable Materials Present: Yes No If Yes: Disturbed Soil Fill Material Weathered/Fractured Rock Bedrock

5. Groundwater Observed: Yes No If yes: _____ Depth Weeping from Pit _____ Depth Standing Water in Hole

Soil Log

Depth (in)	Soil Horizon /Layer	Soil Texture (USDA)	Soil Matrix: Color-Moist (Munsell)	Redoximorphic Features			Coarse Fragments % by Volume		Soil Structure	Soil Consistence (Moist)	Other
				Depth	Color	Percent	Gravel	Cobbles & Stones			
0-4	Pavement	-	-	-	-	-	-	-	-	-	-
4-19	Fill	Loamy Sand	10 YR 5/6	-	-	-	30%	-			
19-30	Fill	Sandy Loam	10 YR 4/1	-	-	-	15%	-			
30-36	Ab	Sandy Loam	10 YR 2/1	-	-	-	-				
36-96	C1	Sandy Loam	10 YR 5/1	-	-	-	10%				

Additional Notes: Site Evaluations were performed by Brian Biagini, EIT– Licensed Soil Evaluator Number 14419.



Form 11 - Soil Suitability Assessment for On-Site Sewage Disposal

C. On-Site Review *(minimum of two holes required at every proposed primary and reserve disposal area)*

Deep Observation Hole Number: 2 Hole # 2/24/2022 Date 10:15 Time 30/cloudy Weather _____ Latitude _____ Longitude:

1. Land Use Parking Lot (e.g., woodland, agricultural field, vacant lot, etc.) - Vegetation - Surface Stones (e.g., cobbles, stones, boulders, etc.) 2-5% Slope (%)

Description of Location: Southern parking lot

2. Soil Parent Material: - Landform - Position on Landscape (SU, SH, BS, FS, TS) -

3. Distances from: Open Water Body 150' feet Drainage Way - feet Wetlands - feet
 Property Line - feet Drinking Water Well - feet Other - feet

4. Unsuitable Materials Present: Yes No If Yes: Disturbed Soil Fill Material Weathered/Fractured Rock Bedrock

5. Groundwater Observed: Yes No If yes: _____ Depth Weeping from Pit _____ Depth Standing Water in Hole

Soil Log

Depth (in)	Soil Horizon /Layer	Soil Texture (USDA)	Soil Matrix: Color-Moist (Munsell)	Redoximorphic Features			Coarse Fragments % by Volume		Soil Structure	Soil Consistence (Moist)	Other
				Depth	Color	Percent	Gravel	Cobbles & Stones			
0-4	Pavement	-	-	-	-	-	-	-	-	-	-
4-25	Fill	Loamy Sand	10 YR 5/6	-	-	-	30%	-	Massive	Friable	
25-35	Ab	Sandy Loam	10 YR 2/1	-	-	-	-	-	Massive	Friable	
35-96	C1	Sandy Loam	10 YR 4/1	-	-	-	10%		Massive	Friable	

Additional Notes: Site Evaluations were performed by Brian Biagini, EIT– Licensed Soil Evaluator Number 14419.



Form 11 - Soil Suitability Assessment for On-Site Sewage Disposal

C. On-Site Review *(minimum of two holes required at every proposed primary and reserve disposal area)*

Deep Observation Hole Number: 3 Hole # 2/24/2022 Date 1:15 Time 30/cloudy Weather _____ Latitude _____ Longitude:

1. Land Use Parking Lot (e.g., woodland, agricultural field, vacant lot, etc.) - Vegetation - Surface Stones (e.g., cobbles, stones, boulders, etc.) 2-5% Slope (%)

Description of Location: Middle parking lot

2. Soil Parent Material: - Landform - Position on Landscape (SU, SH, BS, FS, TS) -

3. Distances from: Open Water Body 150' feet Drainage Way - feet Wetlands - feet
Property Line - feet Drinking Water Well - feet Other - feet

4. Unsuitable Materials Present: Yes No If Yes: Disturbed Soil Fill Material Weathered/Fractured Rock Bedrock

5. Groundwater Observed: Yes No If yes: _____ Depth Weeping from Pit _____ Depth Standing Water in Hole

Soil Log

Depth (in)	Soil Horizon /Layer	Soil Texture (USDA)	Soil Matrix: Color-Moist (Munsell)	Redoximorphic Features			Coarse Fragments % by Volume		Soil Structure	Soil Consistence (Moist)	Other
				Depth	Color	Percent	Gravel	Cobbles & Stones			
0-4	Pavement	-	-	-	-	-	-	-	-	-	-
4-24	Fill	Loamy Sand	10 YR 5/6	-	-	-	30%	0%	Massive	Friable	
24-33	Ab	Sandy Loam	10 YR 2/1	-	-	-		10%	Massive	Friable	
33-70	C1	Sandy Loam	10 YR 4/1	-	-	-	0%		Massive	Friable	
							0%				

Additional Notes: Site Evaluations were performed by Brian Biagini, EIT- Licensed Soil Evaluator Number 14419.



Form 11 - Soil Suitability Assessment for On-Site Sewage Disposal

C. On-Site Review *(minimum of two holes required at every proposed primary and reserve disposal area)*

Deep Observation Hole Number: 4 Hole # 2/24/2022 Date 1:55 Time 30/cloudy Weather _____ Latitude _____ Longitude:

1. Land Use Parking Lot (e.g., woodland, agricultural field, vacant lot, etc.) - Vegetation - Surface Stones (e.g., cobbles, stones, boulders, etc.) 2-5% Slope (%)

Description of Location: Middle parking lot

2. Soil Parent Material: - Landform - Position on Landscape (SU, SH, BS, FS, TS) -

3. Distances from: Open Water Body 150' feet Drainage Way - feet Wetlands - feet
 Property Line - feet Drinking Water Well - feet Other - feet

4. Unsuitable Materials Present: Yes No If Yes: Disturbed Soil Fill Material Weathered/Fractured Rock Bedrock

5. Groundwater Observed: Yes No If yes: _____ Depth Weeping from Pit _____ Depth Standing Water in Hole

Soil Log

Depth (in)	Soil Horizon /Layer	Soil Texture (USDA)	Soil Matrix: Color-Moist (Munsell)	Redoximorphic Features			Coarse Fragments % by Volume		Soil Structure	Soil Consistence (Moist)	Other
				Depth	Color	Percent	Gravel	Cobbles & Stones			
0-4	Pavement	-	-	-	-	-	-	-	-	-	-
4-19	Fill	Loamy Sand	10 YR 5/6	-	-	-	30%	0%	Massive	Friable	
19-30		Sandy Loam	10 YR 4/1	-	-	-		10%	Massive	Friable	
30-36	Ab	Sandy Loam	10 YR 2/1	-	-	-	10%		Massive	Friable	
	Bw						20%				

Additional Notes: Site Evaluations were performed by Brian Biagini, EIT– Licensed Soil Evaluator Number 14419.



Form 11 - Soil Suitability Assessment for On-Site Sewage Disposal

C. On-Site Review *(minimum of two holes required at every proposed primary and reserve disposal area)*

Deep Observation Hole Number: 5 2/24/2022 11:00 30/cloudy
Hole # Date Time Weather Latitude Longitude:

1. Land Use Parking Lot - - -
(e.g., woodland, agricultural field, vacant lot, etc.) Vegetation Surface Stones (e.g., cobbles, stones, boulders, etc.) Slope (%)
 Description of Location: North parking lot

2. Soil Parent Material: - - -
Landform Position on Landscape (SU, SH, BS, FS, TS)

3. Distances from: Open Water Body 150' feet Drainage Way - feet Wetlands - feet
 Property Line - feet Drinking Water Well - feet Other - feet

4. Unsuitable Materials Present: Yes No If Yes: Disturbed Soil Fill Material Weathered/Fractured Rock Bedrock

5. Groundwater Observed: Yes No If yes: - Depth Weeping from Pit 56" Depth Standing Water in Hole

Soil Log

Depth (in)	Soil Horizon /Layer	Soil Texture (USDA)	Soil Matrix: Color-Moist (Munsell)	Redoximorphic Features			Coarse Fragments % by Volume		Soil Structure	Soil Consistence (Moist)	Other
				Depth	Color	Percent	Gravel	Cobbles & Stones			
0-4	Pavement	-	-	-	-	-	-	-	-	-	-
4-12	Fill	Loamy Sand	10 YR 5/6	-	-	-	30%	-	Massive	Friable	
12-44		Sandy Loam	10 YR 3/3	-	-	-		15%	Massive	Friable	
44-64	C2		10 YR 6/4	-	-	-	0%		Massive	Friable	

Additional Notes: Site Evaluations were performed by Brian Biagini, EIT– Licensed Soil Evaluator Number 14419.



Form 11 - Soil Suitability Assessment for On-Site Sewage Disposal

C. On-Site Review *(minimum of two holes required at every proposed primary and reserve disposal area)*

Deep Observation Hole Number: 6 2/24/2022 12:30 30/cloudy - -
Hole # Date Time Weather Latitude Longitude:

1. Land Use Parking Lot - - - 2-5%
(e.g., woodland, agricultural field, vacant lot, etc.) Vegetation Surface Stones (e.g., cobbles, stones, boulders, etc.) Slope (%)

Description of Location: North parking lot

2. Soil Parent Material: - - -
Landform Position on Landscape (SU, SH, BS, FS, TS)

3. Distances from: Open Water Body 150' feet Drainage Way - feet Wetlands - feet
 Property Line - feet Drinking Water Well - feet Other - feet

4. Unsuitable Materials Present: Yes No If Yes: Disturbed Soil Fill Material Weathered/Fractured Rock Bedrock

5. Groundwater Observed: Yes No If yes: 83" Depth Weeping from Pit 93" Depth Standing Water in Hole

Soil Log

Depth (in)	Soil Horizon /Layer	Soil Texture (USDA)	Soil Matrix: Color-Moist (Munsell)	Redoximorphic Features			Coarse Fragments % by Volume		Soil Structure	Soil Consistence (Moist)	Other
				Depth	Color	Percent	Gravel	Cobbles & Stones			
0-4	Pavement	-	-	-	-	-	-	-	-	-	-
4-17	Fill	Loamy Sand	10 YR 5/6	-	-	-	30%		Massive	Friable	-
17-25	Ab	Sandy Loam	10 YR 2/1	-	-	-	10%		Massive	Friable	-
25-36				-	-	-		0%	Massive	Friable	Large stones
	C1		10 YR 6/2				20%	10%			

Additional Notes: Site Evaluations were performed by Brian Biagini, EIT– Licensed Soil Evaluator Number 14419.



Form 11 - Soil Suitability Assessment for On-Site Sewage Disposal

C. On-Site Review *(minimum of two holes required at every proposed primary and reserve disposal area)*

Deep Observation Hole Number: 7 Hole # 3/3/2022 Date 9:00 Time 38/sunny Weather _____ Latitude _____ Longitude:

1. Land Use Parking Lot (e.g., woodland, agricultural field, vacant lot, etc.) - Vegetation - Surface Stones (e.g., cobbles, stones, boulders, etc.) 2-5% Slope (%)

Description of Location: South parking lot

2. Soil Parent Material: - Landform - Position on Landscape (SU, SH, BS, FS, TS) -

3. Distances from: Open Water Body 200' feet Drainage Way - feet Wetlands - feet
 Property Line - feet Drinking Water Well - feet Other - feet

4. Unsuitable Materials Present: Yes No If Yes: Disturbed Soil Fill Material Weathered/Fractured Rock Bedrock

5. Groundwater Observed: Yes No If yes: _____ Depth Weeping from Pit _____ Depth Standing Water in Hole

Soil Log

Depth (in)	Soil Horizon /Layer	Soil Texture (USDA)	Soil Matrix: Color-Moist (Munsell)	Redoximorphic Features			Coarse Fragments % by Volume		Soil Structure	Soil Consistence (Moist)	Other
				Depth	Color	Percent	Gravel	Cobbles & Stones			
0-4	Pavement	-	-	-	-	-	-	-	-	-	-
4-22	Fill	Sand	10 YR 5/4	-	-	-	25%		Massive	Friable	
22-35	Ab	Sandy Loam	10 YR 2/1	-	-	-			Massive	Friable	
35-65			10 YR 4/6	-	-	-	15%		Massive	Friable	
								10%			

Additional Notes: Site Evaluations were performed by Brian Biagini, EIT– Licensed Soil Evaluator Number 14419.



Form 11 - Soil Suitability Assessment for On-Site Sewage Disposal

C. On-Site Review *(minimum of two holes required at every proposed primary and reserve disposal area)*

Deep Observation Hole Number: 8 3/3/2022 10:30 38/sunny
Hole # Date Time Weather Latitude Longitude:

1. Land Use Parking Lot - - -
(e.g., woodland, agricultural field, vacant lot, etc.) Vegetation Surface Stones (e.g., cobbles, stones, boulders, etc.) Slope (%)

Description of Location: Middle parking lot

2. Soil Parent Material: - - -
Landform Position on Landscape (SU, SH, BS, FS, TS)

3. Distances from: Open Water Body 200' feet Drainage Way - feet Wetlands - feet
 Property Line - feet Drinking Water Well - feet Other - feet

4. Unsuitable Materials Present: Yes No If Yes: Disturbed Soil Fill Material Weathered/Fractured Rock Bedrock

5. Groundwater Observed: Yes No If yes: _____ Depth Weeping from Pit _____ Depth Standing Water in Hole

Soil Log

Depth (in)	Soil Horizon /Layer	Soil Texture (USDA)	Soil Matrix: Color-Moist (Munsell)	Redoximorphic Features			Coarse Fragments % by Volume		Soil Structure	Soil Consistence (Moist)	Other
				Depth	Color	Percent	Gravel	Cobbles & Stones			
0-4	Pavement	-	-	-	-	-	-	-	-	-	-
4-23	Fill	Sand	10 YR 5/4	-	-	-	25%		Massive		
23-33	Ab	Sandy Loam	10 YR 2/1	-	-	-			Massive		
33-55			10 YR 4/6	-	-	-	10%		Massive		
								10%			

Additional Notes: Site Evaluations were performed by Brian Biagini, EIT– Licensed Soil Evaluator Number 14419.



Form 11 - Soil Suitability Assessment for On-Site Sewage Disposal

C. On-Site Review *(minimum of two holes required at every proposed primary and reserve disposal area)*

Deep Observation Hole Number: 9 Hole # 3/3/2022 Date 12:30 Time 38/sunny Weather - Latitude - Longitude:

1. Land Use Parking Lot (e.g., woodland, agricultural field, vacant lot, etc.) - Vegetation - Surface Stones (e.g., cobbles, stones, boulders, etc.) 2-5% Slope (%)

Description of Location: North parking lot

2. Soil Parent Material: - Landform - Position on Landscape (SU, SH, BS, FS, TS) -

3. Distances from: Open Water Body 200' feet Drainage Way - feet Wetlands - feet
 Property Line - feet Drinking Water Well - feet Other - feet

4. Unsuitable Materials Present: Yes No If Yes: Disturbed Soil Fill Material Weathered/Fractured Rock Bedrock

5. Groundwater Observed: Yes No If yes: 78" Depth Weeping from Pit _____ Depth Standing Water in Hole

Soil Log

Depth (in)	Soil Horizon /Layer	Soil Texture (USDA)	Soil Matrix: Color-Moist (Munsell)	Redoximorphic Features			Coarse Fragments % by Volume		Soil Structure	Soil Consistence (Moist)	Other
				Depth	Color	Percent	Gravel	Cobbles & Stones			
0-4	Pavement	-	-	-	-	-	-	-	-	-	-
4-13	Fill	Sandy Loam	10 YR 4/1	-	-	-	20%		Massive	Friable	
13-27	Bw	Loamy Sand	10 YR 4/6	-	-	-			Massive	Friable	-
27-84			10 YR 5/3	-	-	-	20%	15%	Massive	Friable	

Additional Notes: Site Evaluations were performed by Brian Biagini, EIT– Licensed Soil Evaluator Number 14419.