



October 19, 2022

New Bedford Conservation Commission
133 William Street, Suite 304
New Bedford, MA 02740

RE: Notice of Intent and Request for Public Hearing
New Bedford Business Park Upgrades Project
Flaherty Drive, New Bedford, MA

Dear Commission Members:

Eversource Energy (Eversource) respectfully submits the enclosed Notice of Intent (NOI) for the New Bedford Business Park Upgrades Project (Project), which would include installation of entrenched underground conduit, manholes, riser poles, and pad mounted switch boxes within Eversource's existing right-of-way (ROW) beginning at Flaherty Drive and extending approximately 3,470 linear feet east.

This NOI is being filed pursuant to the Massachusetts Wetlands Protection Act (WPA). The Project is located within Bordering Vegetated Wetlands, Bank, 100-Foot Buffer Zone, Land Under Waterways and Waterbodies, and Riverfront Area. The Project has been designed to comply with the WPA for proposed work in regulated resource areas.

Please find enclosed the NOI Form and supporting documentation for your review. We respectfully request that the Commission place this matter on the next available meeting agenda. Please don't hesitate to contact Eversource, or myself, at 508-287-3541 or episkura@kleinfelder.com if you have any questions regarding this project. Thank you for your consideration on this matter.

Respectfully yours,

A handwritten signature in brown ink that reads "Eileen Piskura". The signature is written in a cursive style.

Eileen Piskura
Kleinfelder

cc: James Clancy, Eversource Energy



NEW BEDFORD BUSINESS PARK UPRADES

Flaherty Drive
New Bedford, MA

NOTICE OF INTENT

Table of Contents

Notice of Intent Forms

WPA Form 3 – Notice of Intent
NOI Wetland Fee Transmittal Form
Local Wetland Fee Form

Notice of Intent Figures

Figure 1 – USGS Locus Map
Figure 2 – Aerial Map
Figure 3 – Regulated Resources Map

Attachment A – NOI Narrative

Attachment B – Typical Construction Details

Attachment C – Wetland Delineation Report

Attachment D – Abutter Notification



NOI FORMS

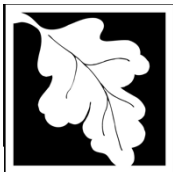

Massachusetts Department of Environmental Protection
 Bureau of Resource Protection - Wetlands

WPA Form 3 – Notice of Intent

Massachusetts Wetlands Protection Act M.G.L. c. 131, §40

Provided by MassDEP:

MassDEP File Number

Document Transaction Number

New Bedford

City/Town

Important:
 When filling out forms on the computer, use only the tab key to move your cursor - do not use the return key.



Note:
 Before completing this form consult your local Conservation Commission regarding any municipal bylaw or ordinance.

A. General Information

1. Project Location (**Note:** electronic filers will click on button to locate project site):

<u>Flaherty Drive</u>	<u>New Bedford</u>	<u>02747</u>
a. Street Address	b. City/Town	c. Zip Code
<u>Latitude and Longitude:</u>	<u>41.71783</u>	<u>-70.96849</u>
	d. Latitude	e. Longitude
<u>133</u>	<u>62, 12, 10, 54, 66</u>	
f. Assessors Map/Plat Number	g. Parcel /Lot Number	

2. Applicant:

<u>James</u>	<u>Clancy</u>	
a. First Name	b. Last Name	
<u>Eversource Energy</u>		
c. Organization		
<u>247 Station Drive, SE270</u>		
d. Street Address		
<u>Westwood</u>	<u>MA</u>	<u>02090</u>
e. City/Town	f. State	g. Zip Code
<u>(781) 441-8159</u>	<u>james.clancy@eversource.com</u>	
h. Phone Number	i. Fax Number	j. Email Address

3. Property owner (required if different from applicant): Check if more than one owner

<u></u>	<u></u>	
a. First Name	b. Last Name	
<u></u>		
c. Organization		
<u></u>		
d. Street Address		
<u></u>	<u></u>	<u></u>
e. City/Town	f. State	g. Zip Code
<u></u>	<u></u>	<u></u>
h. Phone Number	i. Fax Number	j. Email address

4. Representative (if any):

<u>Eileen</u>	<u>Piskura</u>	
a. First Name	b. Last Name	
<u>Kleinfelder</u>		
c. Company		
<u>4 Technology Drive</u>		
d. Street Address		
<u>Westorough</u>	<u>MA</u>	<u>01581</u>
e. City/Town	f. State	g. Zip Code
<u>(508) 287-3541</u>	<u>episkura@kleinfelder.com</u>	
h. Phone Number	i. Fax Number	j. Email address

5. Total WPA Fee Paid (from NOI Wetland Fee Transmittal Form):

<u>\$5,250</u>	<u>\$2,612.5</u>	<u>\$2,637.5</u>
a. Total Fee Paid	b. State Fee Paid	c. City/Town Fee Paid



Massachusetts Department of Environmental Protection
Bureau of Resource Protection - Wetlands

WPA Form 3 – Notice of Intent

Massachusetts Wetlands Protection Act M.G.L. c. 131, §40

Provided by MassDEP:
MassDEP File Number
Document Transaction Number
New Bedford
City/Town

A. General Information (continued)

6. General Project Description:
See attached Project Description

7a. Project Type Checklist: (Limited Project Types see Section A. 7b.)

- 1. Single Family Home
- 2. Residential Subdivision
- 3. Commercial/Industrial
- 4. Dock/Pier
- 5. Utilities
- 6. Coastal engineering Structure
- 7. Agriculture (e.g., cranberries, forestry)
- 8. Transportation
- 9. Other

7b. Is any portion of the proposed activity eligible to be treated as a limited project (including Ecological Restoration Limited Project) subject to 310 CMR 10.24 (coastal) or 310 CMR 10.53 (inland)?

- 1. Yes No If yes, describe which limited project applies to this project. (See 310 CMR 10.24 and 10.53 for a complete list and description of limited project types)

2. Limited Project Type

If the proposed activity is eligible to be treated as an Ecological Restoration Limited Project (310 CMR10.24(8), 310 CMR 10.53(4)), complete and attach Appendix A: Ecological Restoration Limited Project Checklist and Signed Certification.

8. Property recorded at the Registry of Deeds for:

Bristol	
a. County	b. Certificate # (if registered land)
5598; 1578; 1544; 4372; 9852	85; 851; 357; 339; 51
c. Book	d. Page Number

B. Buffer Zone & Resource Area Impacts (temporary & permanent)

- 1. Buffer Zone Only – Check if the project is located only in the Buffer Zone of a Bordering Vegetated Wetland, Inland Bank, or Coastal Resource Area.
- 2. Inland Resource Areas (see 310 CMR 10.54-10.58; if not applicable, go to Section B.3, Coastal Resource Areas).

Check all that apply below. Attach narrative and any supporting documentation describing how the project will meet all performance standards for each of the resource areas altered, including standards requiring consideration of alternative project design or location.

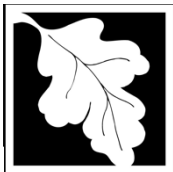

Massachusetts Department of Environmental Protection
Bureau of Resource Protection - Wetlands

WPA Form 3 – Notice of Intent

Massachusetts Wetlands Protection Act M.G.L. c. 131, §40

Provided by MassDEP:

MassDEP File Number

Document Transaction Number

New Bedford
City/Town

B. Buffer Zone & Resource Area Impacts (temporary & permanent) (cont'd)

For all projects affecting other Resource Areas, please attach a narrative explaining how the resource area was delineated.

Resource Area	Size of Proposed Alteration	Proposed Replacement (if any)
a. <input checked="" type="checkbox"/> Bank	120 (temp) 1. linear feet	2. linear feet
b. <input checked="" type="checkbox"/> Bordering Vegetated Wetland	1,853 (temp) 1. square feet	2. square feet
c. <input checked="" type="checkbox"/> Land Under Waterbodies and Waterways	434 (temp) 1. square feet 1.6 3. cubic yards dredged	2. square feet

Resource Area	Size of Proposed Alteration	Proposed Replacement (if any)
d. <input type="checkbox"/> Bordering Land Subject to Flooding	1. square feet 3. cubic feet of flood storage lost	2. square feet 4. cubic feet replaced
e. <input type="checkbox"/> Isolated Land Subject to Flooding	1. square feet 2. cubic feet of flood storage lost	3. cubic feet replaced
f. <input checked="" type="checkbox"/> Riverfront Area	tributaries to Paskamansett River (inland) 1. Name of Waterway (if available) - specify coastal or inland	

2. Width of Riverfront Area (check one):

- 25 ft. - Designated Densely Developed Areas only
- 100 ft. - New agricultural projects only
- 200 ft. - All other projects

3. Total area of Riverfront Area on the site of the proposed project: 407,261
square feet

4. Proposed alteration of the Riverfront Area:

<u>33,435</u>	<u>26,242</u>	<u>7,193</u>
a. total square feet	b. square feet within 100 ft.	c. square feet between 100 ft. and 200 ft.

5. Has an alternatives analysis been done and is it attached to this NOI? Yes No

6. Was the lot where the activity is proposed created prior to August 1, 1996? Yes No

3. Coastal Resource Areas: (See 310 CMR 10.25-10.35)

Note: for coastal riverfront areas, please complete **Section B.2.f.** above.

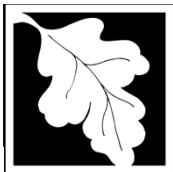

Massachusetts Department of Environmental Protection
Bureau of Resource Protection - Wetlands

WPA Form 3 – Notice of Intent

Massachusetts Wetlands Protection Act M.G.L. c. 131, §40

Provided by MassDEP:
MassDEP File Number
Document Transaction Number
New Bedford
City/Town

B. Buffer Zone & Resource Area Impacts (temporary & permanent) (cont'd)

Check all that apply below. Attach narrative and supporting documentation describing how the project will meet all performance standards for each of the resource areas altered, including standards requiring consideration of alternative project design or location.

Online Users:
Include your document transaction number (provided on your receipt page) with all supplementary information you submit to the Department.

<u>Resource Area</u>	<u>Size of Proposed Alteration</u>	<u>Proposed Replacement (if any)</u>
a. <input type="checkbox"/> Designated Port Areas	Indicate size under Land Under the Ocean, below	
b. <input type="checkbox"/> Land Under the Ocean	_____	
	1. square feet	

	2. cubic yards dredged	
c. <input type="checkbox"/> Barrier Beach	Indicate size under Coastal Beaches and/or Coastal Dunes below	
d. <input type="checkbox"/> Coastal Beaches	_____	_____
	1. square feet	2. cubic yards beach nourishment
e. <input type="checkbox"/> Coastal Dunes	_____	_____
	1. square feet	2. cubic yards dune nourishment

	<u>Size of Proposed Alteration</u>	<u>Proposed Replacement (if any)</u>
f. <input type="checkbox"/> Coastal Banks	_____	
	1. linear feet	
g. <input type="checkbox"/> Rocky Intertidal Shores	_____	
	1. square feet	
h. <input type="checkbox"/> Salt Marshes	_____	_____
	1. square feet	2. sq ft restoration, rehab., creation
i. <input type="checkbox"/> Land Under Salt Ponds	_____	
	1. square feet	

	2. cubic yards dredged	
j. <input type="checkbox"/> Land Containing Shellfish	_____	
	1. square feet	
k. <input type="checkbox"/> Fish Runs	Indicate size under Coastal Banks, inland Bank, Land Under the Ocean, and/or inland Land Under Waterbodies and Waterways, above	

	1. cubic yards dredged	
l. <input type="checkbox"/> Land Subject to Coastal Storm Flowage	_____	
	1. square feet	

4. Restoration/Enhancement
If the project is for the purpose of restoring or enhancing a wetland resource area in addition to the square footage that has been entered in Section B.2.b or B.3.h above, please enter the additional amount here.

_____	_____
a. square feet of BVW	b. square feet of Salt Marsh

5. Project Involves Stream Crossings

3	_____
a. number of new stream crossings	b. number of replacement stream crossings



Massachusetts Department of Environmental Protection
Bureau of Resource Protection - Wetlands

WPA Form 3 – Notice of Intent

Massachusetts Wetlands Protection Act M.G.L. c. 131, §40

Provided by MassDEP:

MassDEP File Number

Document Transaction Number

New Bedford
City/Town

C. Other Applicable Standards and Requirements

- This is a proposal for an Ecological Restoration Limited Project. Skip Section C and complete Appendix A: Ecological Restoration Limited Project Checklists – Required Actions (310 CMR 10.11).

Streamlined Massachusetts Endangered Species Act/Wetlands Protection Act Review

1. Is any portion of the proposed project located in **Estimated Habitat of Rare Wildlife** as indicated on the most recent Estimated Habitat Map of State-Listed Rare Wetland Wildlife published by the Natural Heritage and Endangered Species Program (NHESP)? To view habitat maps, see the *Massachusetts Natural Heritage Atlas* or go to http://maps.massgis.state.ma.us/PRI_EST_HAB/viewer.htm.

a. Yes No **If yes, include proof of mailing or hand delivery of NOI to:**

**Natural Heritage and Endangered Species Program
Division of Fisheries and Wildlife
1 Rabbit Hill Road
Westborough, MA 01581**

15th Edition,
August 2021

If yes, the project is also subject to Massachusetts Endangered Species Act (MESA) review (321 CMR 10.18). To qualify for a streamlined, 30-day, MESA/Wetlands Protection Act review, please complete Section C.1.c, and include requested materials with this Notice of Intent (NOI); *OR* complete Section C.2.f, if applicable. *If MESA supplemental information is not included with the NOI, by completing Section 1 of this form, the NHESP will require a separate MESA filing which may take up to 90 days to review (unless noted exceptions in Section 2 apply, see below).*

c. Submit Supplemental Information for Endangered Species Review*

1. Percentage/acreage of property to be altered:
 - (a) within wetland Resource Area _____ percentage/acreage
 - (b) outside Resource Area _____ percentage/acreage

2. Assessor’s Map or right-of-way plan of site

2. Project plans for entire project site, including wetland resource areas and areas outside of wetlands jurisdiction, showing existing and proposed conditions, existing and proposed tree/vegetation clearing line, and clearly demarcated limits of work **
 - (a) Project description (including description of impacts outside of wetland resource area & buffer zone)
 - (b) Photographs representative of the site

* Some projects **not** in Estimated Habitat may be located in Priority Habitat, and require NHESP review (see <https://www.mass.gov/endangered-species-act-mesa-regulatory-review>).

Priority Habitat includes habitat for state-listed plants and strictly upland species not protected by the Wetlands Protection Act.

** MESA projects may not be segmented (321 CMR 10.16). The applicant must disclose full development plans even if such plans are not required as part of the Notice of Intent process.

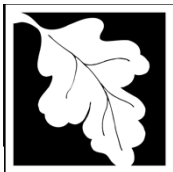

Massachusetts Department of Environmental Protection
Bureau of Resource Protection - Wetlands

WPA Form 3 – Notice of Intent

Massachusetts Wetlands Protection Act M.G.L. c. 131, §40

Provided by MassDEP:

MassDEP File Number

Document Transaction Number

New Bedford

City/Town

C. Other Applicable Standards and Requirements (cont'd)

- (c) MESA filing fee (fee information available at <https://www.mass.gov/how-to/how-to-file-for-a-mesa-project-review>).

Make check payable to "Commonwealth of Massachusetts - NHESP" and **mail to NHESP** at above address

Projects altering 10 or more acres of land, also submit:

- (d) Vegetation cover type map of site

- (e) Project plans showing Priority & Estimated Habitat boundaries

- (f) OR Check One of the Following

1. Project is exempt from MESA review.
Attach applicant letter indicating which MESA exemption applies. (See 321 CMR 10.14, <https://www.mass.gov/service-details/exemptions-from-review-for-projectsactivities-in-priority-habitat>; the NOI must still be sent to NHESP if the project is within estimated habitat pursuant to 310 CMR 10.37 and 10.59.)

2. Separate MESA review ongoing. a. NHESP Tracking # _____ b. Date submitted to NHESP _____

3. Separate MESA review completed.
Include copy of NHESP "no Take" determination or valid Conservation & Management Permit with approved plan.

3. For coastal projects only, is any portion of the proposed project located below the mean high water line or in a fish run?

- a. Not applicable – project is in inland resource area only b. Yes No

If yes, include proof of mailing, hand delivery, or electronic delivery of NOI to either:

South Shore - Cohasset to Rhode Island border, and
the Cape & Islands:

North Shore - Hull to New Hampshire border:

Division of Marine Fisheries -
Southeast Marine Fisheries Station
Attn: Environmental Reviewer
836 South Rodney French Blvd.
New Bedford, MA 02744
Email: dmf.envreview-south@mass.gov

Division of Marine Fisheries -
North Shore Office
Attn: Environmental Reviewer
30 Emerson Avenue
Gloucester, MA 01930
Email: dmf.envreview-north@mass.gov

Also if yes, the project may require a Chapter 91 license. For coastal towns in the Northeast Region, please contact MassDEP's Boston Office. For coastal towns in the Southeast Region, please contact MassDEP's Southeast Regional Office.

- c. Is this an aquaculture project? d. Yes No

If yes, include a copy of the Division of Marine Fisheries Certification Letter (M.G.L. c. 130, § 57).

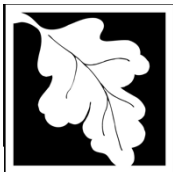

Massachusetts Department of Environmental Protection
Bureau of Resource Protection - Wetlands

WPA Form 3 – Notice of Intent

Massachusetts Wetlands Protection Act M.G.L. c. 131, §40

Provided by MassDEP:
MassDEP File Number
Document Transaction Number
New Bedford
City/Town

Online Users:
Include your document transaction number (provided on your receipt page) with all supplementary information you submit to the Department.

C. Other Applicable Standards and Requirements (cont'd)

- 4. Is any portion of the proposed project within an Area of Critical Environmental Concern (ACEC)?
 a. Yes No If yes, provide name of ACEC (see instructions to WPA Form 3 or MassDEP Website for ACEC locations). **Note:** electronic filers click on Website.
 b. ACEC

- 5. Is any portion of the proposed project within an area designated as an Outstanding Resource Water (ORW) as designated in the Massachusetts Surface Water Quality Standards, 314 CMR 4.00?
 a. Yes No
- 6. Is any portion of the site subject to a Wetlands Restriction Order under the Inland Wetlands Restriction Act (M.G.L. c. 131, § 40A) or the Coastal Wetlands Restriction Act (M.G.L. c. 130, § 105)?
 a. Yes No
- 7. Is this project subject to provisions of the MassDEP Stormwater Management Standards?
 a. Yes. Attach a copy of the Stormwater Report as required by the Stormwater Management Standards per 310 CMR 10.05(6)(k)-(q) and check if:
 - 1. Applying for Low Impact Development (LID) site design credits (as described in Stormwater Management Handbook Vol. 2, Chapter 3)
 - 2. A portion of the site constitutes redevelopment
 - 3. Proprietary BMPs are included in the Stormwater Management System.
 b. No. Check why the project is exempt:
 - 1. Single-family house
 - 2. Emergency road repair
 - 3. Small Residential Subdivision (less than or equal to 4 single-family houses or less than or equal to 4 units in multi-family housing project) with no discharge to Critical Areas.

D. Additional Information

- This is a proposal for an Ecological Restoration Limited Project. Skip Section D and complete Appendix A: Ecological Restoration Notice of Intent – Minimum Required Documents (310 CMR 10.12).

Applicants must include the following with this Notice of Intent (NOI). See instructions for details.

Online Users: Attach the document transaction number (provided on your receipt page) for any of the following information you submit to the Department.

- 1. USGS or other map of the area (along with a narrative description, if necessary) containing sufficient information for the Conservation Commission and the Department to locate the site. (Electronic filers may omit this item.)
- 2. Plans identifying the location of proposed activities (including activities proposed to serve as a Bordering Vegetated Wetland [BVW] replication area or other mitigating measure) relative to the boundaries of each affected resource area.



Massachusetts Department of Environmental Protection
Bureau of Resource Protection - Wetlands

WPA Form 3 – Notice of Intent

Massachusetts Wetlands Protection Act M.G.L. c. 131, §40

Provided by MassDEP:
MassDEP File Number
Document Transaction Number
New Bedford
City/Town

D. Additional Information (cont'd)

3. Identify the method for BVW and other resource area boundary delineations (MassDEP BVW Field Data Form(s), Determination of Applicability, Order of Resource Area Delineation, etc.), and attach documentation of the methodology.

4. List the titles and dates for all plans and other materials submitted with this NOI.

Delineated Wetlands & Watercourses

a. Plan Title	
Kleinfelder	
b. Prepared By	c. Signed and Stamped by
October 2022	
d. Final Revision Date	e. Scale
f. Additional Plan or Document Title	g. Date

- 5. If there is more than one property owner, please attach a list of these property owners not listed on this form.
- 6. Attach proof of mailing for Natural Heritage and Endangered Species Program, if needed.
- 7. Attach proof of mailing for Massachusetts Division of Marine Fisheries, if needed.
- 8. Attach NOI Wetland Fee Transmittal Form
- 9. Attach Stormwater Report, if needed.

E. Fees

1. Fee Exempt: No filing fee shall be assessed for projects of any city, town, county, or district of the Commonwealth, federally recognized Indian tribe housing authority, municipal housing authority, or the Massachusetts Bay Transportation Authority.

Applicants must submit the following information (in addition to pages 1 and 2 of the NOI Wetland Fee Transmittal Form) to confirm fee payment:

13132	10/20/22
2. Municipal Check Number	3. Check date
13134	10-20-22
4. State Check Number	5. Check date
Kleinfelder Office Checking	
6. Payor name on check: First Name	7. Payor name on check: Last Name



Massachusetts Department of Environmental Protection
Bureau of Resource Protection - Wetlands

WPA Form 3 – Notice of Intent



Massachusetts Wetlands Protection Act M.G.L. c. 131, §40

Provided by MassDEP:
MassDEP File Number
Document Transaction Number
New Bedford
City/Town

F. Signatures and Submittal Requirements

I hereby certify under the penalties of perjury that the foregoing Notice of Intent and accompanying plans, documents, and supporting data are true and complete to the best of my knowledge. I understand that the Conservation Commission will place notification of this Notice in a local newspaper at the expense of the applicant in accordance with the wetlands regulations, 310 CMR 10.05(5)(a).

I further certify under penalties of perjury that all abutters were notified of this application, pursuant to the requirements of M.G.L. c. 131, § 40. Notice must be made by Certificate of Mailing or in writing by hand delivery or certified mail (return receipt requested) to all abutters within 100 feet of the property line of the project location.

 1. Signature of Applicant	10/19/2022 2. Date
3. Signature of Property Owner (if different)	4. Date
 5. Signature of Representative (if any)	10/19/2022 6. Date

For Conservation Commission:

Two copies of the completed Notice of Intent (Form 3), including supporting plans and documents, two copies of the NOI Wetland Fee Transmittal Form, and the city/town fee payment, to the Conservation Commission by certified mail or hand delivery.

For MassDEP:

One copy of the completed Notice of Intent (Form 3), including supporting plans and documents, one copy of the NOI Wetland Fee Transmittal Form, and a **copy** of the state fee payment to the MassDEP Regional Office (see Instructions) by certified mail or hand delivery.

Other:

If the applicant has checked the "yes" box in any part of Section C, Item 3, above, refer to that section and the Instructions for additional submittal requirements.

The original and copies must be sent simultaneously. Failure by the applicant to send copies in a timely manner may result in dismissal of the Notice of Intent.



Massachusetts Department of Environmental Protection
 Bureau of Resource Protection - Wetlands
NOI Wetland Fee Transmittal Form
 Massachusetts Wetlands Protection Act M.G.L. c. 131, §40

Important: When filling out forms on the computer, use only the tab key to move your cursor - do not use the return key.

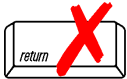

A. Applicant Information

1. Location of Project:

Flaherty Drive	New Bedford
a. Street Address	b. City/Town
13134	2,612.50
c. Check number	d. Fee amount

2. Applicant Mailing Address:

James	Clancy	
a. First Name	b. Last Name	
Eversource Energy		
c. Organization		
247 Station Drive, Suite SE270		
d. Mailing Address		
Westwood	MA	02090
e. City/Town	f. State	g. Zip Code
(781) 441-8159	james.clancy@eversource.com	
h. Phone Number	i. Fax Number	j. Email Address

3. Property Owner (if different):

a. First Name	b. Last Name	
c. Organization		
d. Mailing Address		
e. City/Town	f. State	g. Zip Code
h. Phone Number	i. Fax Number	j. Email Address

B. Fees

Fee should be calculated using the following process & worksheet. **Please see Instructions before filling out worksheet.**

Step 1/Type of Activity: Describe each type of activity that will occur in wetland resource area and buffer zone.

Step 2/Number of Activities: Identify the number of each type of activity.

Step 3/Individual Activity Fee: Identify each activity fee from the six project categories listed in the instructions.

Step 4/Subtotal Activity Fee: Multiply the number of activities (identified in Step 2) times the fee per category (identified in Step 3) to reach a subtotal fee amount. Note: If any of these activities are in a Riverfront Area in addition to another Resource Area or the Buffer Zone, the fee per activity should be multiplied by 1.5 and then added to the subtotal amount.

Step 5/Total Project Fee: Determine the total project fee by adding the subtotal amounts from Step 4.

Step 6/Fee Payments: To calculate the state share of the fee, divide the total fee in half and subtract \$12.50. To calculate the city/town share of the fee, divide the total fee in half and add \$12.50.

To calculate filing fees, refer to the category fee list and examples in the instructions for filling out WPA Form 3 (Notice of Intent).



MAYOR
JON MITCHELL

City of New Bedford Conservation Commission • Department of Environmental Stewardship

133 William Street • Room 304 • New Bedford, Massachusetts 02740

Telephone: (508) 991.6188

Conservation • Environmental Stewardship • Resilience

CITY OF NEW BEDFORD, MASSACHUSETTS

CONSERVATION COMMISSION 2022 FILING FEE CALCULATION WORKSHEET*

PROJECT LOCATION: Flaherty Drive

MAP(S) 133 LOT(S) 62, 12, 10, 54, 66

APPLICANT: Eversource Energy

CONSERVATION COMMISSION APPLICATION TYPE:

- REQUEST FOR DETERMINATION OF APPLICABILITY
- NOTICE OF INTENT
- AMENDED ORDER OF CONDITIONS
- EXTENSION PERMIT
- CERTIFICATE OF COMPLIANCE

(A) ALTERATION FEES:

Application and field review of a project proposed in a Wetland Resource Area or its Buffer Zone is \$200.00 plus the applicable alteration fee as follows:

	AMOUNT DUE:
• Application and Field Review Fee (\$200.00)	\$ <u>200.00</u>
• \$0.50 X <u>1,853</u> SF Wetland Resource Area Fee shall not exceed \$2000.00 per project	\$ <u>926.50</u>
• \$0.05 X _____ SF of Isolated Land Subject to Flooding, Bordering Land Subject to Flooding or Land Subject to Coastal Storm Flowage Fee shall not exceed \$500.00	\$ _____
• \$0.50 X <u>7,377</u> SF of altered 25' Riverfront Area Fee shall not exceed \$1,500.00	\$ <u>1,500</u>
• \$1.00 X _____ SF of undeveloped 25' Riverfront Area Fee shall not exceed \$2000.00	\$ _____
• \$5.00 X <u>120</u> LF of Coastal or Inland Bank Fee shall not exceed \$750.00	\$ <u>600</u>



- \$0.10 X 4,500.50 SF of Buffer Zone altered \$ 4,500.50
Fee shall not exceed \$6,500.00
- \$10.00 X _____ LF of dock \$ _____
- \$10.00 X _____ acres of aquaculture \$ _____

(B) EXTENSION OF AN ORDER OF CONDITIONS:

- Single family dwelling, or minor project (house addition, in ground pool dock etc.) = \$200.00 \$ _____
- Subdivision, commercial or industrial project = \$400.00 \$ _____

(C) AMENDING A PERMIT

- Single family dwelling or minor project (house addition, in ground pool dock etc.) = \$200.00 + new alteration fee – refer to (A) above \$ _____
- Subdivision, commercial or industrial project = \$500.00 + new alteration fee – refer to (A) above \$ _____

(D) WETLAND DELINEATION VERIFICATION (with or without proposed alteration)

- ½ acre or less
- ½ acre to 2 acres = \$500.00 (\$100/acre thereafter) not to exceed \$3,500 \$ _____

(E) LEGAL AD FEE (fee set by local newspaper, subject to market price) \$ 250.00

(F) CERTIFICATES OF COMPLIANCE

- One new house = \$250.00 \$ _____
- One activity at an existing house = \$150.00 \$ _____
- Residential or Commercial docks = \$200.00 \$ _____
- Commercial & Industrial Facilities = \$1,500.00 \$ _____
- New Roadways & Associated Stormwater Mgt. Systems = \$1,500.00 \$ _____

Partial Certificates of Compliance have the same fee as a Certificate of Compliance, But you only pay the fee once (you do not pay double to obtain a full Certificate of Compliance).

(G) AFTER THE FACT FILING FEE

- Notice of Intent or Amended Order of Conditions = \$500.00 \$ _____
- Request for a Determination of Applicability = \$250.00 \$ _____

TOTAL AMOUNT DUE: \$ 7,977

Notes:

*Please refer to the Conservation Commission fee schedule – dated 02/2020

Please make check or Money Order payable to the City of New Bedford
Cash is not accepted.



13132

KLEINFELDER OFFICE CHECKING

550 WEST C STREET SUITE 1200
SAN DIEGO, CA 92101

19-10/1250

DATE 10/20/22

PAY TO THE
ORDER OF

City of New Bedford

\$ 2,157.50

Two Thousand Six Hundred Thirty Seven Dollars and 50/100 —

DOLLARS



usbank.

FOR 20224947, 0001TRK 02-0000 - Permit Fee Spencer H. Cookpair



MP

13133

19-10/250

DATE 10/20/22

\$ 7,997.00

Security Features
Included
Details on back.

DOLLARS

KLEINFELDER OFFICE CHECKING
550 WEST C STREET SUITE 1200
SAN DIEGO, CA 92101

PAY TO THE
ORDER OF

City of New Bedford
Seven Thousand Nine Hundred Ninety Seven Dollars Only

usbank.

FOR

20224947.001A TRASK 02-0000/PERMIT Fee Spald County Ga

MP

KLEINFELDER OFFICE CHECKING
550 WEST C STREET SUITE 1200
SAN DIEGO, CA 92101

13134

19-10/1250

PAY TO THE
ORDER OF

Commonwealth of Massachusetts
two thousand six hundred twelve billion and 50/100

DATE

10-20-22

\$ *2,612.50*

DOLLARS



Security Features
Details on Back

USbank

FOR

20224947.0018 / 7188C 02-0000 / Permit Fee
Frank H. Desjardins

MP



NOI FIGURES

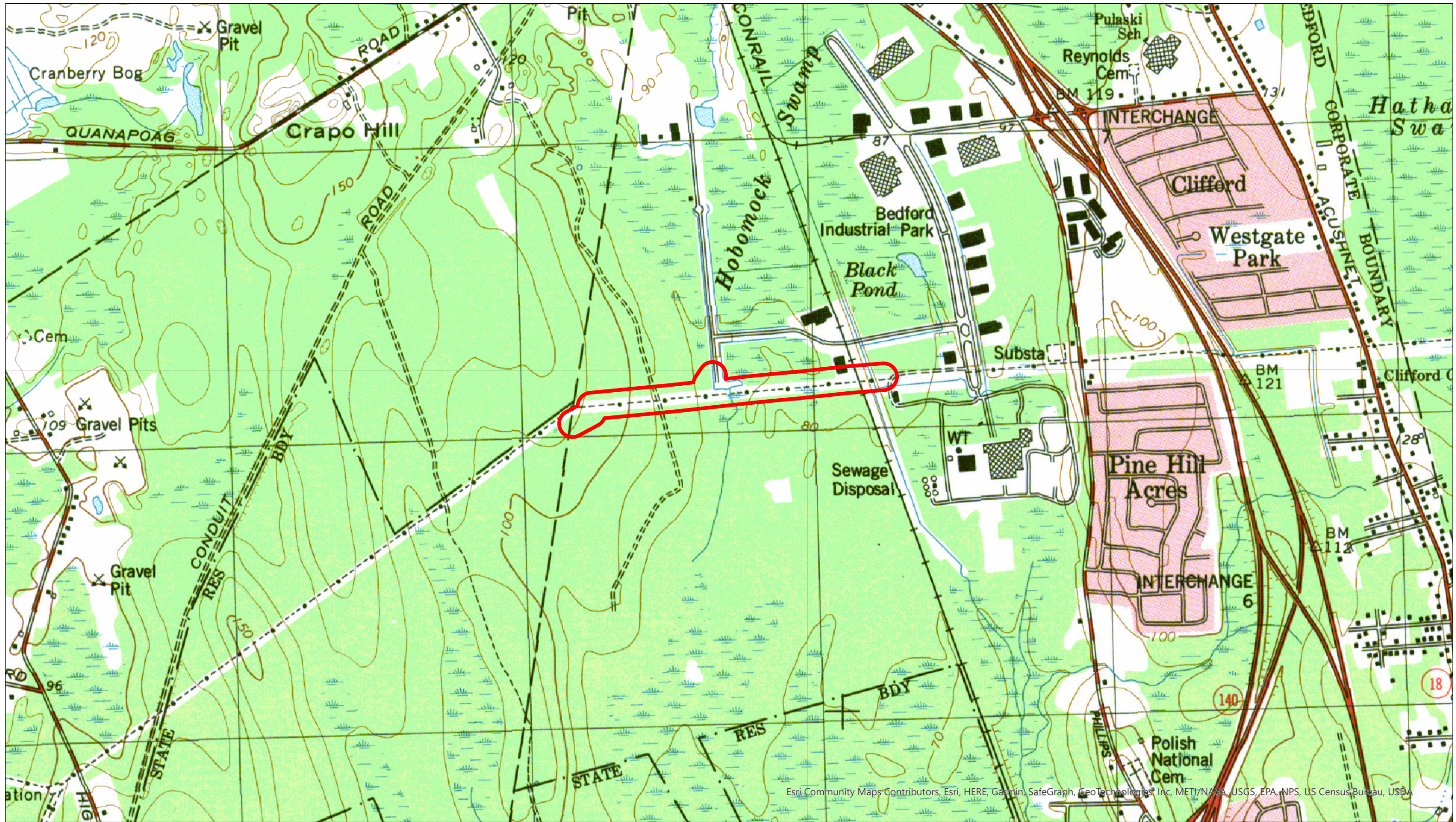

Esri Community Maps Contributors, Esri, HERE, Garmin, SafeGraph, GeoTechnology, Inc, METI/NASA, USGS, EPA, NPS, US Census Bureau, USDA

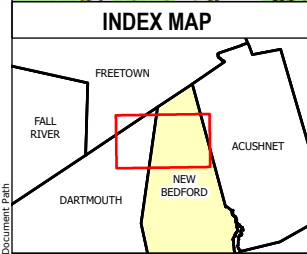

Legend
 Area Of Investigation

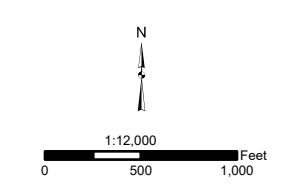

NO.	DATE	REVISIONS

EVERSOURCE
ENERGY

Figure 1 - Project Locus
New Bedford Business Park Upgrade

New Bedford, MA	MAP SHEET 1 of 1
Date: September, 2022	

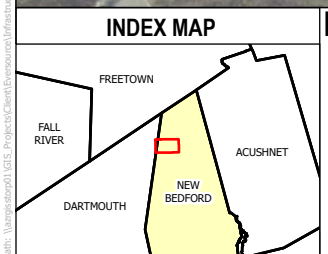

Legend

- Existing Structure
- Proposed Structure
- Proposed Riser Pole
- Existing Manhole
- Proposed Manhole
- Padmounted Switch Box Pad
- * Certified Vernal Pool
- ☼ Potential Vernal Pool (Not within map view)
- Existing Ducts, Concrete Encased
- Proposed Ducts, Concrete Encased
- Railroad
- Area Of Investigation
- Rare Species (Not within map view)
- Area of Environmental Concern (Not within map view)
- Outstanding Resource Waters (Not within map view)

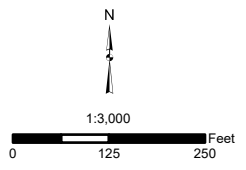

NO.	DATE	REVISIONS

EVERSOURCE ENERGY

**Figure 2 - Aerial Map
New Bedford Business Park Upgrade**

New Bedford, MA MAP SHEET 1 of 1

Date: October, 2022

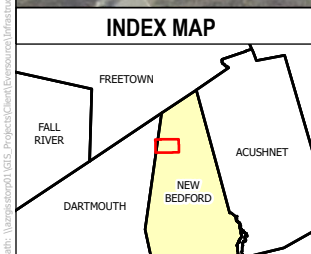

Legend

- Existing Structure
- Proposed Structure
- Proposed Riser Pole
- Existing Manhole
- Proposed Manhole
- Padmounted Switch Box Pad
- Culvert
- Existing Ducts, Concrete Encased
- Proposed Ducts, Concrete Encased
- Railroad
- 100' Buffer to BW
- 100' Buffer to Bank
- 200' Riverfront Area
- Delineated Intermittent Watercourse
- Delineated Perennial Watercourse
- Open Water
- Field Delineated Wetland
- Area Of Investigation
- 20' Disturbance Area

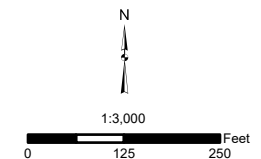

NO.	DATE	REVISIONS

EVERSOURCE ENERGY
Figure 3 - Delineated Wetlands & Watercourses
New Bedford Business Park Upgrade

New Bedford, MA MAP SHEET 1 of 1
 Date: October, 2022

Bright People. Right Solutions.



ATTACHMENT A
NOI Narrative



Attachment A – Notice of Intent Narrative

This Notice of Intent (NOI) is filed pursuant to the Massachusetts Wetlands Protection Act (WPA) (MGL Chapter 131, Section 40) and its implementing regulations (310 CMR 10.00). This narrative presents regulated resource areas associated with the New Bedford Business Park Upgrades (Project) area, a description of the proposed work, proposed mitigation measures, and how the Project meets the performance standards of the WPA regulations.

Introduction

Eversource Energy proposes to install entrenched underground conduit along their right-of-way (ROW) beginning at Flaherty Drive and extending approximately 3,470 linear feet east. Additional infrastructure proposed to support the conduit includes manholes, riser poles, and pad mounted switch boxes. All work will occur within Eversource's existing ROW.

Proposed work for the Project would occur within the following WPA regulated resources: Bordering Vegetated Wetlands (BVW), 100-foot Buffer Zone, Bank, Riverfront Area, and Land Under Water Bodies and Waterways (LUWW). The Project meets or exceeds all performance standards for these resources under the WPA.

Site Description

The Project area is located on Eversource's existing and maintained ROW beginning at Flaherty Drive, New Bedford and extending east. Eversource' ROW is within a business park surrounded by multiple buildings and coinciding with a paved storage area for Eastern Fisheries and railroad crossing near the eastern end of the Project area. An existing access road extends down the ROW the entire length of the Project including an existing culvert conveying stream flow beneath the road. An aquatic resources delineation of the Project area performed on February 22, 2022 and March 1, 2022 (detailed below), identified eight BVW and two perennial stream features. Please refer to Figure 1 for a USGS map of the Project area, and to Figures 2 and 3 for a tax parcel and aquatic resources map of the Project area.

According to the most recently available data provided by the Massachusetts Natural Heritage and Endangered Species Program (NHESP), no Priority Habitat for Rare Species or Estimated Habitat for Rare Wildlife have been mapped in the vicinity of the Project area. The Project Area is not located within or near an Area of Critical Environmental Concern (ACEC). According to the Massachusetts Department of Environmental Protection (DEP) and the Project area is not located within an Outstanding Resource Water area. According to the Natural Resources Conservation Service (NRCS) soil survey, soils in the Project area are mapped as Pipestone loamy sand, Swansea muck, Ridgebury fine sandy loam, Whitman fine sandy loam, Sudbury fine sandy loam, Paxton fine sandy loam, Woodbury fine sandy loam, and Urban land. NHESP indicates that a mapped certified vernal pool is located south of the Project area (Figure 3). This vernal pool is within delineated wetland W06 and will not be impacted during construction.

Regulated Resource Areas

Bordering Vegetated Wetland and Buffer Zone

Aquatic resources in or near the Project Area were identified and delineated by environmental scientists from Kleinfelder on February 22, 2022 and March 1, 2022, in accordance with methods developed by the Massachusetts Department of Environmental Protection (MassDEP) and U.S. Army Corps of Engineers (USACE). Resource areas are shown on the accompanying Project plans, and wetland data forms are included in Attachment C. Eight Bordering Vegetated Wetlands (BVW) were delineated in the Project Area. Dominant vegetation within the wetland includes *Pinus strobus*, *Acer rubrum*, *Conus alba*, *multiflora rosa*, and *Onoclea sensibilis*. A 100-foot Buffer Zone extends horizontally outward from the BVW boundary, and it contains woodlands and borders the two perennial stream.

Land Under Waterbodies and Waterways, Banks, Riverfront Area

Two unnamed perennial tributaries and one intermittent tributary to the Paskamansett River were delineated during field investigations. The ordinary high-water mark (OHWM) for the tributaries were flagged as S01 and S02 (intermittent and perennial tributaries) in the field. OHWM was determined based on field indicators such as changes in slope, changes in vegetation, stain lines and changes in bank materials. Primary channel bed substrate consists of cobble and gravel. The perennial portion of Stream S02 flows north-south across the ROW with intermittent tributaries flowing into east-west into it. Stream S02 is culverted under the existing access road and has a width of approximately 2 feet and an average depth of water of approximately 1 foot. Stream S01 is perennial and flows north-south across the Project area before turning east at the southern end of the ROW. It has a width of approximately 2 feet and an average depth of water of approximately 1 foot. The riverfront area extends 200 feet horizontal to the delineated OHWM of the perennial streams. The submerged portion of the tributaries is considered LUWW and the vertical portion of each tributary that confines the flowing water is considered a Bank resource under the WPA.

Proposed Activities

Proposed work includes installation of entrenched underground conduit, manholes, riser poles, and pad mounted switch boxes within Eversource's ROW beginning at Flaherty Drive and extending east approximately 3,470 linear feet. The conduit trench would be excavated to approximately 3.5 feet below grade (fbg) for installation, which includes excavating in BVW, Bank, and LUWW, and backfilled with excavated material. The trench width would be approximately 1-foot, with a potentially disturbed area of approximately 20 feet centered over the trench. Infrastructure would also be installed within the 100-foot buffer to BVW, 100-foot buffer to Bank, and 200-foot Riverfront area of the perennial streams. Impacts to regulated resources includes a total of approximately: 120 linear feet of temporary impact to Bank (assumed 40 feet of impact per stream); 1,853 square feet of temporary impact to BVW; 434 square feet of temporary impact to LUWW; 42 cubic feet (1.6 cubic yards) of LUWW would be dredged (assuming 2 feet in length east to west, 2 feet wide north to south, and 3.5 feet below the stream bed for each stream).

Prior to initiating excavation activities, Eversource would install erosion control devices around the work area and silt curtains at the north and south sides of the stream crossing. Minor tree and shrub clearing are necessary to allow equipment access to the proposed work area. Infrastructure installation would commence once erosion control devices are in place.

Work associated with the installation of the water line includes the excavation and temporary stockpiling of soils. Excavated soils would be stockpiled within the work area and surrounded by erosion control devices. Additionally, associated equipment and supplies would be stored outside of the buffer zones and no fueling of equipment would take place within the buffer zones.

Eversource intends to temporarily redirect the perennial stream during trenching activities under the stream. The stream would be blocked on the upstream and downstream sides of the excavation area by check dams while trenching is conducted. Water would be then pumped via a pump from the upstream side of the excavation area to the downstream side. Eversource would use suction strainers on the pump suction line and discharge hose to reduce turbidity of the diverted water. Straw wattles and/or strawbales would be used at the end of the discharge hose to act as a sediment trap for any disturbed silt/sedimentation during diversion activities before re-entering the stream. Eversource would monitor water levels at the upstream and downstream dams to ensure the pump is adequately maintaining stream flow, as well as conduct visual inspection of the discharge area, to ensure water discharged into the stream has minimal turbidity. Any groundwater encountered during trenching activities would be dewatered to a sediment filtration structure in an upland area.

Stream S02 has an existing culvert under the access road within the ROW that has failed. As part of this project, Eversource would replace the culvert in-kind and restore the access road so vehicles can cross without impacting the stream.



After the conduit is installed under the stream, the trench would be backfilled with the excavated material and the stream flow restored. The bank and any disturbed soils would be stabilized with biodegradable erosion control blankets.

Upon completion of construction activities, the work area would be returned to its pre-construction grade and restored with loam and native seed mix.

Compliance with Massachusetts Storm Water Policy

Massachusetts Stormwater Management Policy and the standards at 310 CMR 10.05(6)(k) are generally not applicable because the Project is not creating any impervious surfaces, stormwater conveyances, or stormwater systems covered by the standards. The Stormwater standards and the manner the Project complies with them are summarized as follows:

- Standard 1: Negligible new impervious surfaces will be constructed in the form of manholes, riser poles, and pad mounted switch boxes and there will be no new stormwater point source discharges to untreated stormwater into, or causing erosion to, wetlands and waters.
- Standard 2: Post-development peak discharge rates will not exceed pre-development peak discharge rates.
- Standard 3: This Project will result in negligible new impervious surfaces in the form of manholes, riser poles, and pad mounted switch boxes and no increase in impervious area or no loss of groundwater recharge will occur.
- Standard 4: This Project will result in negligible new impervious area and therefore does not require TSS removal facilities.
- Standard 5: This Project does not contain land uses with higher potential pollutants as described in MassDEP's Stormwater Management Policy.
- Standard 6: This Project will not result in any new point-source discharges and will not, therefore, discharge to or affect a critical area.
- Standard 7: This Project will result in negligible new impervious and no point source discharges and therefore, Standards 1, 2, 3, 4, 5, 6, 7, 9, and 10 are generally not applicable. Compliance with Standard 8 is discussed below.
- Standard 8: Erosion and sedimentation controls for construction and land disturbance activities have been incorporated into the Project design. Further, the Project will require a Construction General Permit from the Environmental Protection Agency that will incorporate a Stormwater Pollution Prevention Plan (SWPPP) as part of that submission. The contractor will be required comply with the provisions of the Construction General Permit and SWPPP throughout construction.
- Standard 9: No structural stormwater treatment devices are warranted or proposed for this Project (because no increase in impervious surfaces will occur), therefore, an Operation and Maintenance Plan is not necessary.
- Standard 10: No illicit discharges to a stormwater management system will occur.

Alternative Analysis

Based upon the presence of Riverfront Area resources in the Project Area, the Project proponent performed an alternatives analysis, as described below.



The new conduit must connect from the existing conduit on Flaherty Drive east to the business park located north and east of the work area. Eversource sited the proposed route to minimize impacts to regulated resources by using the existing Eversource ROW and avoiding permanent impacts to wetlands and streams. The conduit installation is proposed from Flaherty Drive, running east through the subject property, under two perennial streams toward the existing building. Any alternative route would involve installation outside of the existing ROW and would require obtaining new legal easements as well as Alternatives were rejected as the line must run through the existing Eversource right of way.

The chosen alternative represents the shortest distance from the current conduit to the commercial building, and although it crosses through regulated resources, it is the alternative that minimizes impacts to regulated resources while satisfying the Project purpose and need.

Regulatory Compliance

As demonstrated below, the proposed Project complies with and exceeds applicable performance standards for work in BVW, 100-foot Buffer Zone to BVW, Bank, 100-foot buffer to Bank, Riverfront Area, and Land Under Water Bodies and Waterways. Compliance with the applicable performance standards for each resource is described in more detail below.

Bordering Vegetated Wetlands

The general performance standards for BVW set forth in 301 CMR 10.55(4) are; *(a) where the presumption set forth in 310 CMR 10.55(3) is not overcome, any proposed work in a Bordering Vegetated Wetland shall not destroy or otherwise impair any portion of said area ; (b) Notwithstanding the provisions of 310 CMR 10.55(4)(a), the issuing authority may issue an Order of Conditions permitting work which results in the loss of up to 5000 square feet of Bordering Vegetated Wetland when said area is replaced in accordance with the following general conditions and any additional, specific conditions the issuing authority deems necessary to ensure that the replacement area will function in a manner similar to the area that will be lost. (c) Notwithstanding the provisions of 310 CMR 10.55(4)(a), the issuing authority may issue an Order of Conditions permitting work which results in the loss of a portion of Bordering Vegetated Wetland; (d) Notwithstanding the provisions of 310 CMR 10.55(4)(a),(b) and (c), no project may be permitted which will have any adverse effect on specified habitat sites of rare vertebrate or invertebrate species, as identified by procedures established under 310 CMR 10.59; (e) A(e) Any proposed work shall not destroy or otherwise impair any portion of a Bordering Vegetated Wetland that is within an Area of Critical Environmental Concern designated by the Secretary of Energy and Environmental Affairs under M.G.L. c. 21A, § 2(7) and 301 CMR 12.00: Areas of Critical Environmental Concern.*

The Project has been designed to address these general performance standards. Impacts to BVW have been minimized, and as a result 1,853 sq ft. of the features would be within the area of disturbance, and all impacts would be brief and temporary. Straw wattles would be installed around the work area during construction to minimize potential impacts to adjacent, undisturbed portions of BVW. Work within BVW would be expedited to the extent practicable and any stockpiled soils would be surrounded by erosion control devices. Any soils disturbed within the BVW would be backfilled, stabilized with biodegradable erosion control blankets and seeded with a native wetland seed mix. Additionally, associated equipment and supplies would be stored outside of the buffer zones and no fueling of equipment would take place within the buffer zones.

Table 1: Impacts to BVW	
Wetland ID	Proposed Temporary Impacts (square feet)
W01	0
W02	0
W03	128

W04	26
W05	1,377
W06	0
W07	0
W08	322
Total	1,853

Buffer Zone

The Buffer Zone is not a resource area and, therefore, work within a Buffer Zone is not governed by specific regulatory performance standards. In general, work within a Buffer Zone is permissible when said work has been designed, or can be conditioned, such that there will be no impact on the downgradient wetland resource area(s) being buffered. As stated in 310 CMR 10.53(1) of the WPA Regulations:

For work in Buffer Zone subject to review under 310 CMR 10.02(2)(b)3., the Issuing Authority shall impose conditions to protect the interests of the Act identified for the adjacent Resource Area... The issuing authority may consider the characteristics of the Buffer Zone, such as the presence of steep slopes, that may increase the potential for adverse impacts on Resource Areas. Conditions may include limitations on the scope and location of work in the Buffer Zone as necessary to avoid alteration of Resource Areas. The Issuing Authority may require erosion and sedimentation controls during construction, a clear limit of work, and the preservation of natural vegetation adjacent to the Resource Area and/or other measures commensurate with the scope and location of work with the Buffer Zone to protect the interests of the Act.

As described above, the Project has been designed to address the considerations associated with Buffer Zones, such as erosion control measures. Measures have been incorporated into the Project design to ensure that work will be done in a manner that prevents impacts to downgradient wetland resources. A clear limit of work will be identified, and erosion and sedimentation control areas will be established in the Project area. Straw wattles will be placed around the work area to prevent movement of debris from the disturbance area into the Buffer Zone. Temporary disturbance in vegetated areas of Buffer Zone will be restored in place and seeded with a native seed mix following completion of construction.

Bank

The general performance standards for bank set forth in 310 CMR 10.54(4) are: *the proposed work will not impair the physical stability of the Bank; the water carrying capacity of the existing channel within the Bank; the ground water and surface water quality; the capacity of the Bank to provide breeding habitat, escape cover and food for fisheries; the capacity of the Bank to provide important wildlife habitat functions. A project or projects on a single lot, for which Notice(s) of Intent is filed on or after November 1, 1987, that (cumulatively) alter(s) up to 10% or 50 feet (whichever is less) of the length of the bank found to be significant to the protection of wildlife habitat, shall not be deemed to impair its capacity to provide important wildlife habitat functions. In the case of a bank of a river or an intermittent stream, the impact shall be measured on each side of the stream or river. Additional alterations beyond the above threshold may be permitted if they will have no adverse effects on wildlife habitat, as determined by procedures contained in 310 CMR 10.60.*

The Project has been designed to address these general performance standards for bank resources. The impact to bank resources would be 40 feet for each stream, which is less than 10% of the total feature length and less than 50 feet. During excavation of the stream, the stream would be blocked on the upstream and downstream sides of the excavation area with check dams. Eversource proposes to use suction strainers on the pump suction line and discharge hose to reduce turbidity of the diverted water. Before re-entering the stream, the water would pass through a straw wattle or straw bale structure to allow sedimentation to settle

prior to returning to the stream. After the conduit is installed under the stream, the trench and banks would be back-filled and the stream flow restored. As a result, the proposed work will not impair the physical stability of the banks, the water carrying capacity of the channel, or the surface and groundwater quality. The stream is an urban stream and subject to regular human disturbance. Bank disturbance would be expedited to the minimal amount practicable and the banks would be stabilized after the completion of construction using biodegradable erosion control blankets and seeded. Due to the limited extent and duration of the proposed work, in combination with the existing level of human disturbance, the project is not anticipated to impact the existing wildlife habitat functions provided by bank resources.

Riverfront Area

The general performance standards for riverfront area set forth in 301 CMR 10.58(4) are: *Where the presumption set forth in 310 CMR 10.58(3) is not overcome, the applicant shall prove by a preponderance of the evidence that there are no practicable and substantially equivalent economic alternatives to the proposed project with less adverse effects on the interests identified in M.G.L. c.131 § 40 and that the work, including proposed mitigation, will have no significant adverse impact on the riverfront area to protect the interests identified in M.G.L. c. 131 § 40. In the event that the presumption is partially overcome, the issuing authority shall make a written determination setting forth its grounds in the Order of Conditions and the partial rebuttal shall be taken into account in the application of 310 CMR 10.58 (4)(d)1.a. and c.; the issuing authority shall impose conditions in the Order that contribute to the protection of interests for which the riverfront area is significant.*

The Project was designed to address the performance standards identified in 310 CMR 10.58(4) for the work conducted in Riverfront Area. As demonstrated in the “Alternatives Analysis” section above, the chosen pipeline route represents the alternative for which there are no other substantially equivalent economic alternatives to the proposed Project with less adverse effects. The Project also meets performance criteria for other regulated resources and therefore satisfies all performance standards for Riverfront Area.

Land Under Water Bodies and Waterways

The general performance standard set forth in 301 CMR 10.56(4) are; *(a) Where the presumption set forth in 310 CMR 10.56(3) is not overcome, any proposed work within Land under Water Bodies and Waterways shall not impair the following: 1. The water carrying capacity within the defined channel, which is provided by said land in conjunction with the banks; 2. Ground and surface water quality; 3. The capacity of said land to provide breeding habitat, escape cover and food for fisheries; and 4. The capacity of said land to provide important wildlife habitat functions. A project or projects on a single lot, for which Notice(s) of intent is filed on or after November 1, 1987, that (cumulatively) alter(s) up to 10% or 5,000 square feet (whichever is less) of land in this resource area found to be significant to the protection of wildlife habitat, shall not be deemed to impair its capacity to provide important wildlife habitat functions.*

The Project has been designed to address and comply with general performance standards for LUWW; and in addition, the proposed Project does not include work associated with new/existing stream crossing structures and therefore performance criteria associated with those structures is not addressed.

During excavation of the stream and placement of the new conduit in the below-grade trench the stream would be blocked on the upstream and downstream sides of the excavation area with check dams. Eversource proposes to use suction strainers on the pump suction line and discharge hose to reduce turbidity of the diverted water. Before re-entering the stream, the water would pass through a straw wattle or straw bale structure to allow sedimentation to settle prior to returning to the stream. After the conduit is installed under the stream, the in-stream portion of trench would be back-filled and the stream flow would be restored. The streams are in existing ROW in a business park and have been subject to previous human disturbance. The banks would be stabilized after the completion of construction using biodegradable erosion control blankets and seeded. As a result, the proposed work will not impair the water carrying capacity of the channel, the surface and groundwater quality associated with the stream, and the capacity



of the channel to support wildlife habitat. Impacts to LUWW have been minimized such that 92 square feet of impact to stream S01 and 342 square feet of impacts to stream S02 are proposed. Due to the limited extent and duration of the proposed work, in combination with the existing level of human disturbance, the Project is not anticipated to impact the existing functions of the resource listed in 301 CMR 10.56(4) of the WPA and the Project meets the performance criteria for LUWW.

Mitigation

The proposed installation of the conduit has been sited to reduce impacts to wetlands and other regulated resources to the greatest extent practicable by siting it along a majority upland route within an existing ROW. Erosion and sediment control measures will be implemented to minimize temporary impacts to regulated resource areas during the construction phase of the Project. The measures include Best Management Practices (BMPs) specified in guidelines developed by Eversource for use in all their projects. Proper implementation of the erosion and sedimentation control measures includes:

- Minimize exposed soil areas through sequencing and temporary stabilization;
- Place structures to manage stormwater runoff and erosion; and
- Establish a permanent vegetative cover or other forms of stabilization following construction and as soon as practicable.

Construction Best Management Practices

Construction best management practices to be implemented during construction include temporary stabilization, permanent seeding, and erosion and sedimentation controls. These practices will be initiated as soon as practicable in appropriate areas within the Project area.

Temporary Stabilization

Soil stockpiles will be surrounded by erosion control devices.

Permanent Seeding

Upon completion of the Project, all disturbed areas will be seeded with a native seed mix. The site will be stabilized with biodegradable erosion control blankets, with a layer of straw and seed underneath. The seed mix will be applied at a rate specified by the manufacturer.

Erosion Control Barriers

Prior to any ground disturbance, an approved erosion control barrier, specifically straw wattles, will be installed around the limit of disturbance of the work area and installed around the base of stockpiles and other erosion prone areas. The barriers will be staked into the substrate to prevent underflow. If sediment has accumulated to a depth which impairs proper functioning of the barrier, it will be removed by hand or by machinery operating upslope of the barriers. This material will be either reused in the Project area or disposed of at a suitable offsite location. Any damaged sections of the barrier will be repaired or replaced immediately upon discovery.

Summary

The Applicant respectfully requests that the New Bedford Conservation Commission find these measures adequately protective of the interests identified in the WPA and issue an Order of Conditions approving the work described in this NOI, as shown on the accompanying figures.



ATTACHMENT B
Typical Construction Details

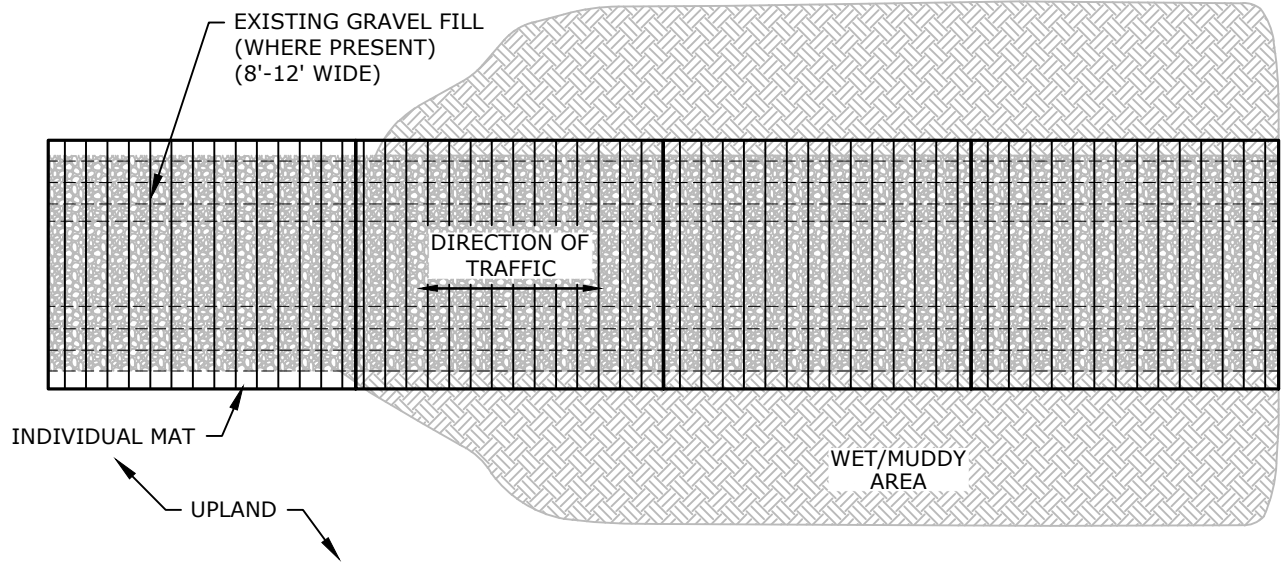

PLAN VIEW

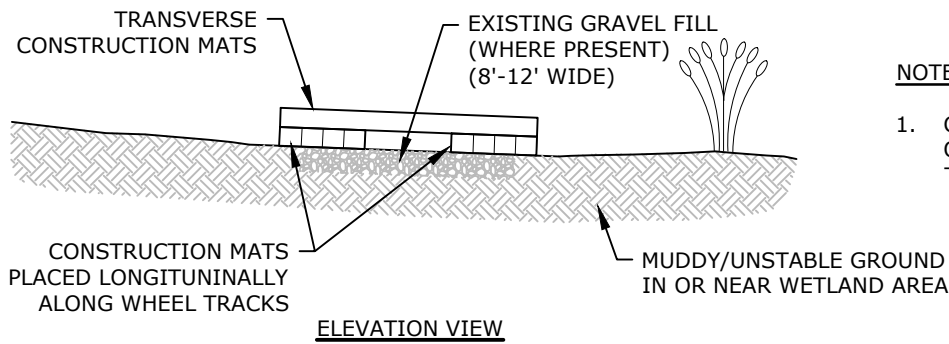

NOTES:

1. CONSTRUCTION MAT DIMENSIONS OF 12'x4'x8", 16'x4'x8" OR OTHER TO BE USED.



**CONSTRUCTION MAT
(WETLAND CROSSING)**

DATE:	12/2021
SCALE:	NO SCALE
FIGURE:	A05



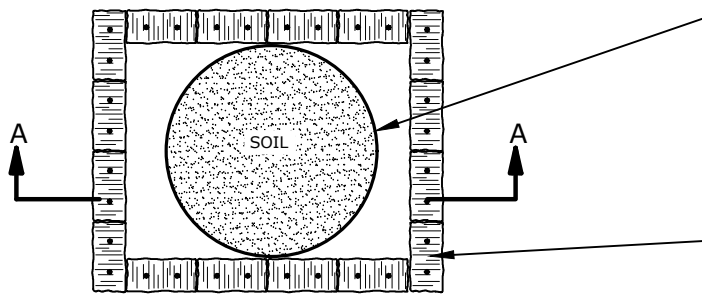

CONTAMINATED SOILS MUST BE ON AND COVERED WITH POLYETHYLENE SHEETING TO LIMIT EROSION. SHEETING NOT REQUIRED FOR NON-CONTAMINATED SOILS IF SEDIMENTATION AND EROSION CONTROLS COMPLETELY ENCLOSE STOCKPILE.

STRAW BALES AND/OR SILT FENCE

PLAN VIEW

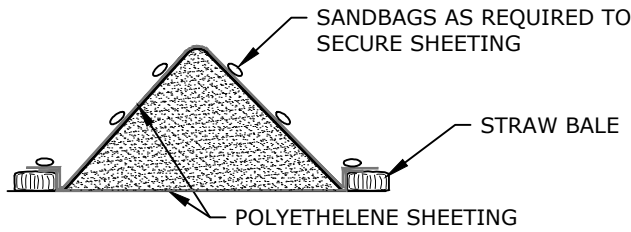

SECTION A-A

NOTE:

1. SANDBAGS (OR SIMILAR) MAY BE USED TO SECURE POLYETHYLENE SHEETING ON TOP OF THE STOCKPILE.
2. STRAW PRODUCTS ONLY; THE USE OF HAY OR HAY PRODUCTS IS STRICTLY PROHIBITED.

SOIL STOCKPILE

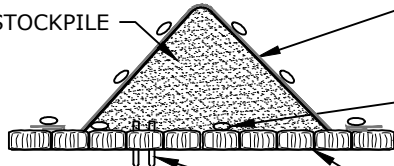

ELEVATION VIEW

CONTAMINATED SOILS MUST BE ON AND COVERED WITH POLYETHYLENE SHEETING TO LIMIT EROSION. SHEETING NOT REQUIRED FOR NON-CONTAMINATED SOILS IF SEDIMENTATION AND EROSION CONTROLS COMPLETELY ENCLOSE STOCKPILE.

SANDBAG EACH BALE IN PAVED AREAS (TYP)
STRAW BALES AND/OR SILT FENCE

BALES TO BUTT TOGETHER
2 STAKES EACH BALE IN UNPAVED AREAS (TYP)



SOIL STOCKPILE MANAGEMENT

DATE:	12/2021
SCALE:	NO SCALE
FIGURE:	A19



NOTES:

1. TOPSOIL SEGREGATION TO BE USED IN WETLANDS AND AGRICULTURAL LAND.
2. IF WORKING WITHIN WETLANDS, MATTING BENEATH STOCKPILES MUST BE LINED OR UNDERLAIN BY GEOTEXTILE FABRIC.
3. STOCKPILES SHOULD BE ENCLOSED BY STRAW BALES OR WATTLES.

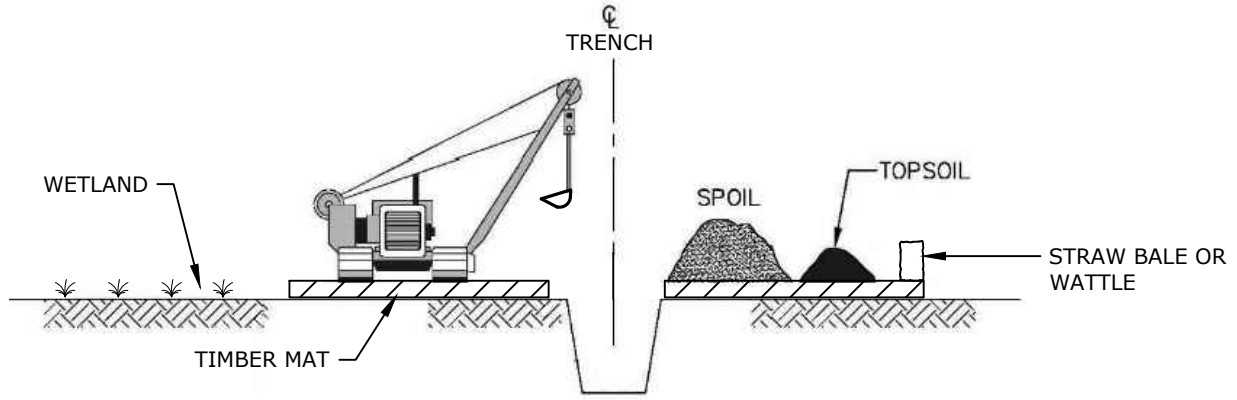

Dec 15, 2021-3:29pm Plotted By: ASapelli
Tighe & Bond, Inc. F:\Projects\E\E5034 Eversource L&P 2019\088 - CT-MA BMP Manual\Drawings_Figures\AutoCAD\Sheet\Topsoil.dwg

TOPSOIL SEGREGATION

DATE:	12/2021
SCALE:	NO SCALE
FIGURE:	A20



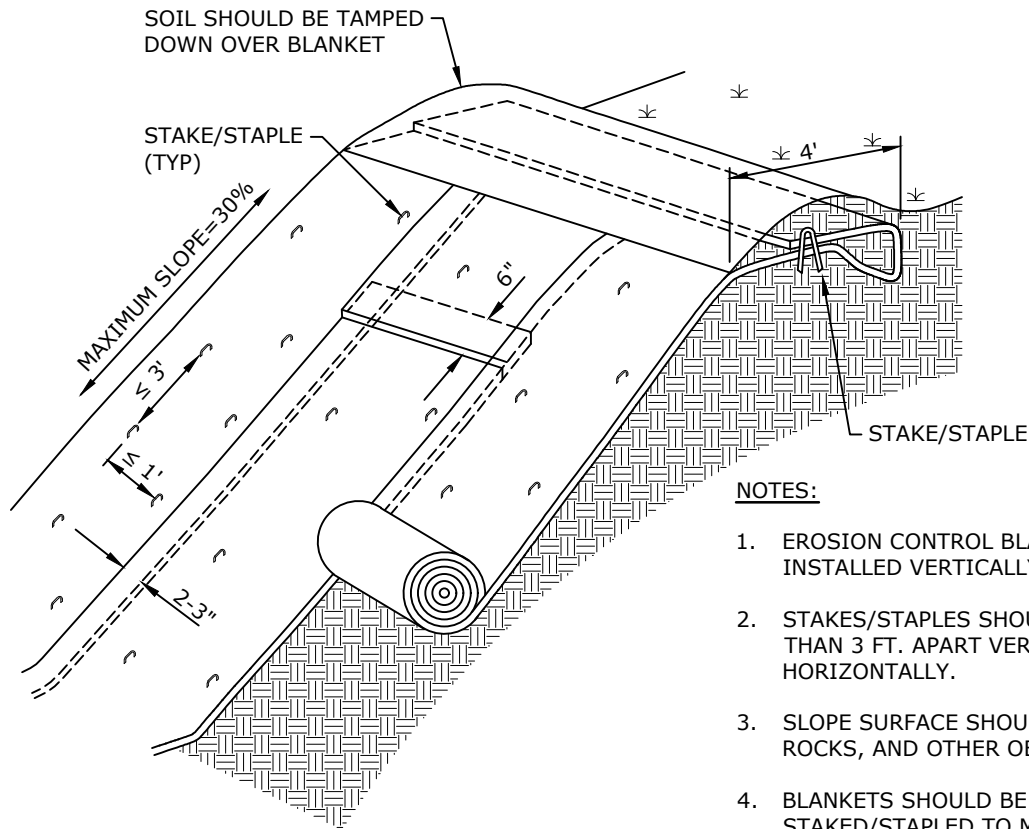

NOTES:

1. EROSION CONTROL BLANKET SHOULD BE INSTALLED VERTICALLY DOWNSLOPE.
2. STAKES/STAPLES SHOULD BE PLACED NO MORE THAN 3 FT. APART VERTICALLY, AND 1 FT. APART HORIZONTALLY.
3. SLOPE SURFACE SHOULD BE FREE OF STICKS, ROCKS, AND OTHER OBSTRUCTIONS.
4. BLANKETS SHOULD BE ROLLED OUT LOOSELY AND STAKED/STAPLED TO MAINTAIN DIRECT SOIL CONTACT. DO NOT STRETCH THE BLANKETS.
5. USE OF PRODUCTS WITH PLASTIC AND/OR NYLON NETTING IS PROHIBITED.



EROSION CONTROL BLANKETS

DATE:	12/2021
SCALE:	NO SCALE
FIGURE:	A25



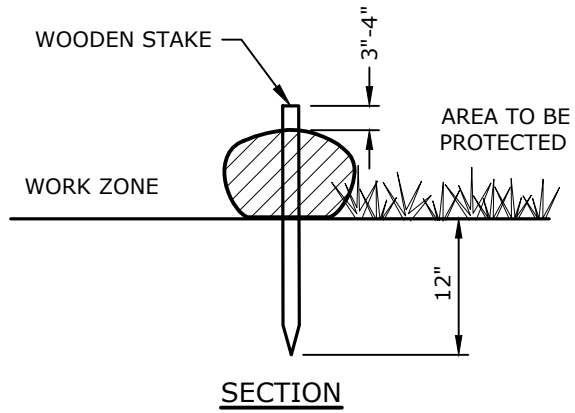
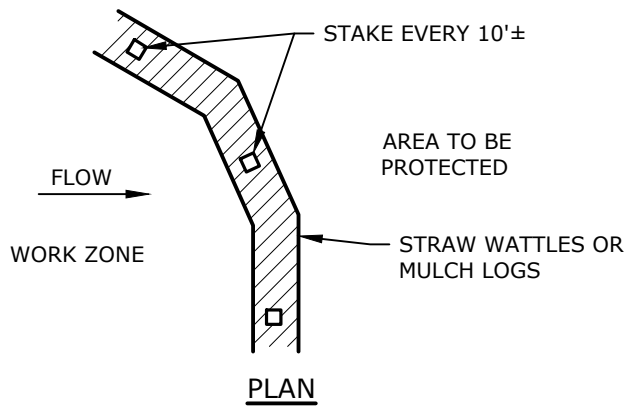

NOTE:

1. USE OF PRODUCTS WITH PLASTIC AND/OR NYLON NETTING IS PROHIBITED.



STRAW WATTLE/MULCH LOG

DATE:	12/2021
SCALE:	NO SCALE
FIGURE:	A26



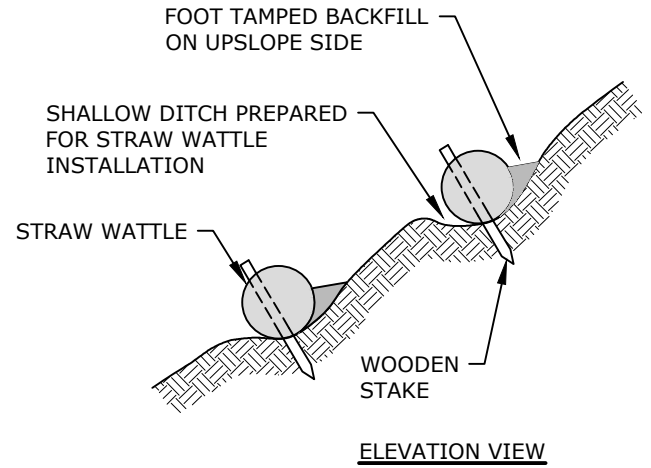
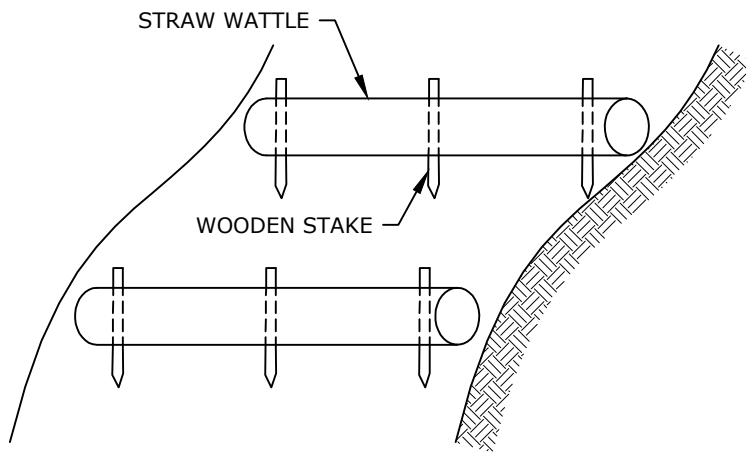

NOTES:

1. USE OF PRODUCTS WITH PLASTIC AND/OR NYLON NETTING IS PROHIBITED.
2. VERTICAL SPACING FOR SLOPE INSTALLATIONS TO BE DETERMINED BY SITE CONDITIONS: SLOPE GRADIENT AND SOIL TYPE. CONFIRM SPACING PER MANUFACTURER'S SPECIFICATIONS. SEE BELOW FOR TYPICAL REQUIREMENTS. COORDINATE SPACING AND LOCATION WITH EVERSOURCE ENVIRONMENTAL LICENSING AND PERMITTING.
 - 1:1 SLOPES = 10 FEET APART
 - 2:1 SLOPES = 20 FEET APART
 - 3:1 SLOPES = 30 FEET APART
3. MINIMUM 12" DIAMETER WATTLES SHOULD BE USED FOR HIGHLY DISTURBED AREAS (E.G. HEAVILY USED ACCESS ROADS WITH ADJACENT WETLANDS). MINIMUM 8" DIAMETER WATTLES SHOULD BE USED FOR LESS DISTURBED SOILS.

Dec 15, 2021-3:28pm Plotted By: ASapelli Tighe & Bond, Inc. F:\Projects\E\5034 Eversource L&P 2019\088 - CT-MA BMP Manual\Drawings_Figures\AutoCAD\Sheet\Straw Wattle.dwg

STRAW WATTLE (ON SLOPE)	
DATE:	12/2021
SCALE:	NO SCALE
FIGURE:	A27
EVERSOURCE	

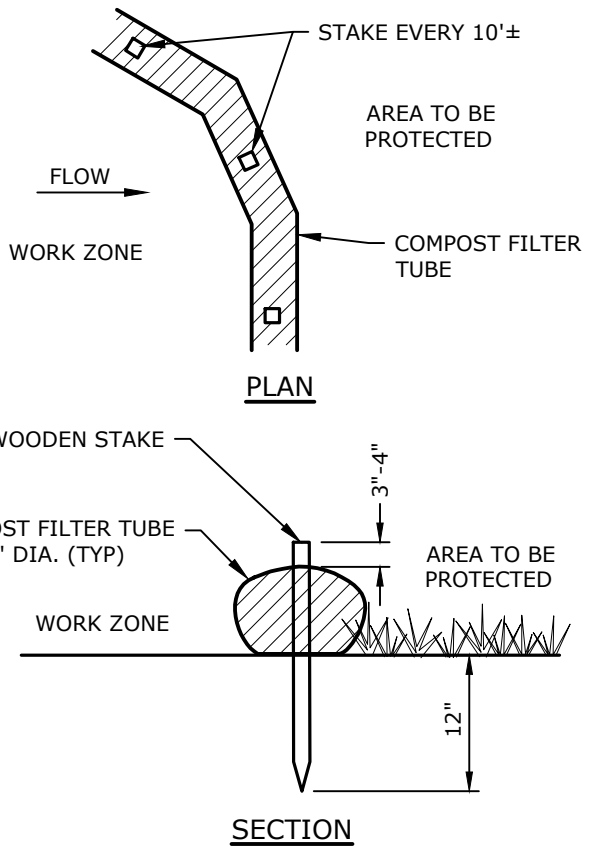

- NOTES:**
1. TUBES FOR COMPOST FILTERS SHALL BE JUTE MESH OR APPROVED BIODEGRADABLE MATERIAL.
 2. TAMP TUBES IN PLACE TO ENSURE GOOD CONTACT WITH SOIL SURFACE.
 3. PROVIDE 3' MINIMUM OVERLAP AT ENDS OF TUBES TO JOIN IN A CONTINUOUS BARRIER AND MINIMIZE UNIMPEDED FLOW.
 4. COMPOST MATERIAL SHALL BE DISPERSED ON SITE WITHIN LIMITS OF WORK, AS DIRECTED.
 5. INSTALL TUBES ALONG CONTOURS AND PERPENDICULAR TO SHEET OR CONCENTRATED FLOW.
 6. DO NOT INSTALL IN PERENNIAL, EPHEMERAL, OR INTERMITTENT STREAMS.
 7. CONFIGURE TUBES AROUND EXISTING SITE FEATURES TO MINIMIZE SITE DISTURBANCE AND MAXIMIZE CAPTURE AREA OF STORMWATER RUN-OFF.



COMPOST FILTER TUBE	
DATE:	12/2021
SCALE:	NO SCALE
FIGURE:	A28



Dec 15, 2021-3:22pm Plotted By: ASapelli Tighe & Bond, Inc. F:\Projects\15E5034 Eversource L&P 2019\088 - CT-MA BMP Manual\Drawings_Figures\AutoCAD\Sheet\Compost Filter Tube.dwg

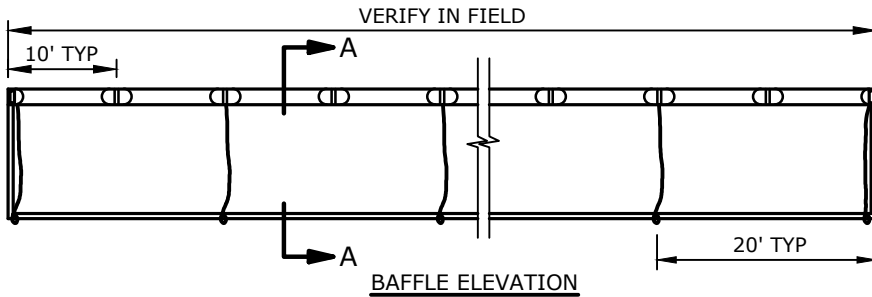

BAFFLE ELEVATION

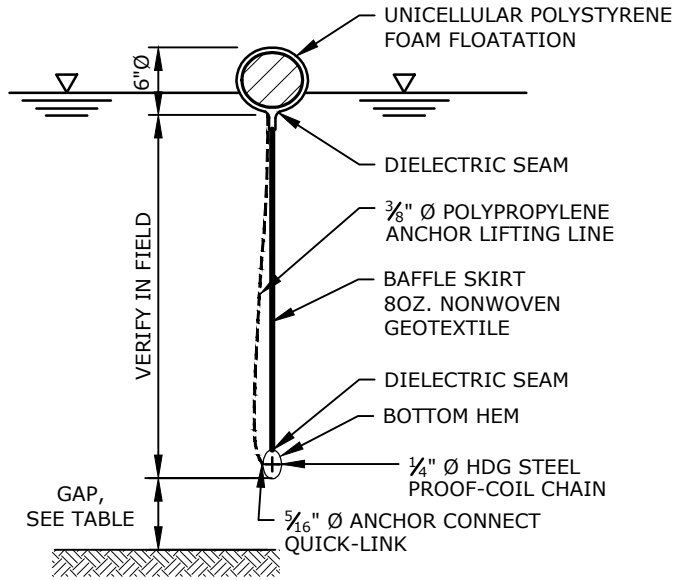

SECTION A-A

NOTES:

1. TURBIDITY CURTAIN BY ENVIRONETICS, INC. OR APPROVED EQUAL.
2. TURBIDITY CURTAIN SHALL NOT BE EXTENDED ACROSS CHANNEL FLOWS.
3. TURBIDITY CURTAIN MATERIAL SHALL BE ULTRAVIOLET LIGHT RESISTANT.

<u>TYPE</u>	<u>DESCRIPTION</u>	<u>CONDITIONS</u>	<u>GAP (IN.)</u>
I	FLATWATER	CALM AND PROTECTED	0
II	LIGHTWEIGHT	SEMI-PROTECTED AREA, CURRENTS UP TO 2 FT/S	12
III	MIDDLEWEIGHT	EXPOSED AREA, CURRENTS UP TO 5 FT/S	12
IV	HEAVYWEIGHT	EXPOSED TO WIND, CURRENT, AND TIDES	0

Dec 15, 2021-3:29pm Plotted By: ASapelli Tighe & Bond, Inc. F:\Projects\15E5034 Eversource L&P 2019\088 - CT-MA BMP Manual\Drawings_Figures\AutoCAD\Sheet\Turbidity Curtain.dwg

TURBIDITY CURTAIN	
DATE: 12/2021	EVERSOURCE
SCALE: NO SCALE	
FIGURE: A29	

NOTE:

THE SEED MIX UTILIZED SHALL CONSIST OF QUICK GROWING, DROUGHT TOLERANT, NATIVE GRASSES, SUCH AS RYES. THE SEED MIX UTILIZED WITHIN THE BUFFER ZONE TO WETLAND RESOURCE AREAS MAY CONSIST OF QUICK GROWING, DROUGHT TOLERANT, NATIVE GRASSES BUT MUST CONTAIN AT LEAST 50% OF A NATIVE SEED MIX WITH HIGH HABITAT VALUE, SUCH AS ONES WHICH CONTAIN PERENNIAL SHRUBS, WILDFLOWERS. CONSULT WITH EVERSOURCE ENVIRONMENTAL LICENSING AND PERMITTING FOR PROJECT SPECIFIC REQUIREMENTS.

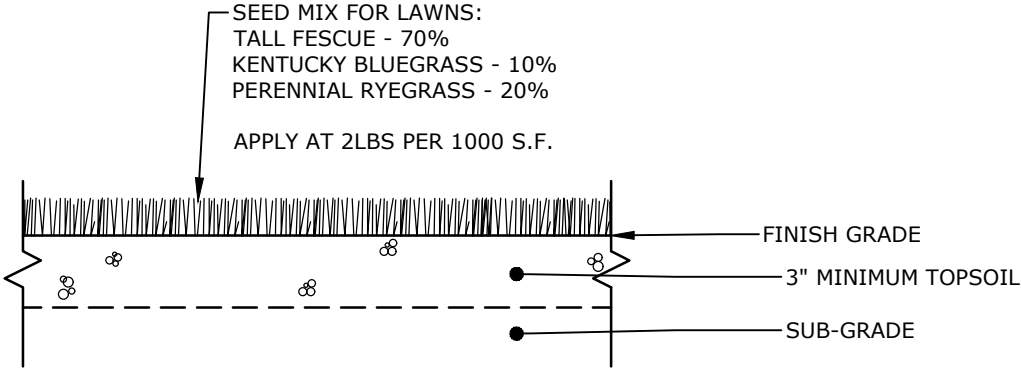

LOAM AND SEED	
DATE:	12/2021
SCALE:	NO SCALE
FIGURE:	A32



NOTES:

1. STRAW PRODUCTS ONLY; THE USE OF HAY OR HAY PRODUCTS IS STRICTLY PROHIBITED.
2. MULCH APPLICATION SHALL NOT EXCEED 1" IN THICKNESS.
3. WOOD CHIPS MAY BE SUBSTITUTED FOR STRAW MULCH SUBJECT TO EVERSOURCE ENVIRONMENTAL LICENSING AND PERMITTING APPROVAL.
4. CONSULT WITH EVERSOURCE ENVIRONMENTAL LICENSING AND PERMITTING FOR PROJECT SPECIFIC REQUIREMENTS.

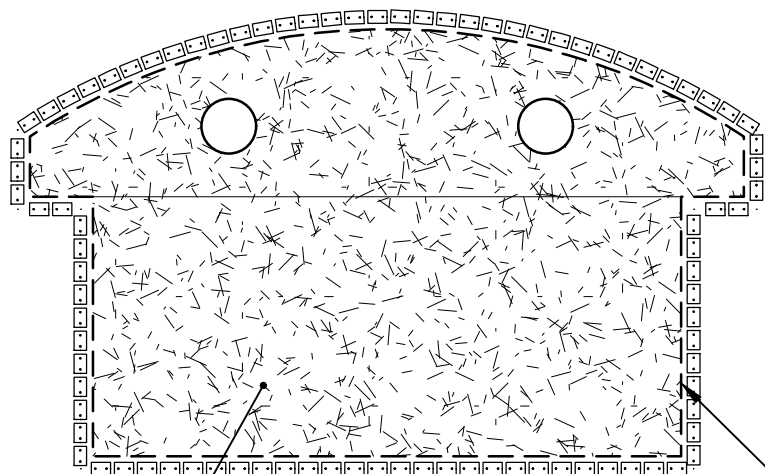

PLAN VIEW

LIMIT OF SOIL DISTURBANCE

STRAW MULCH

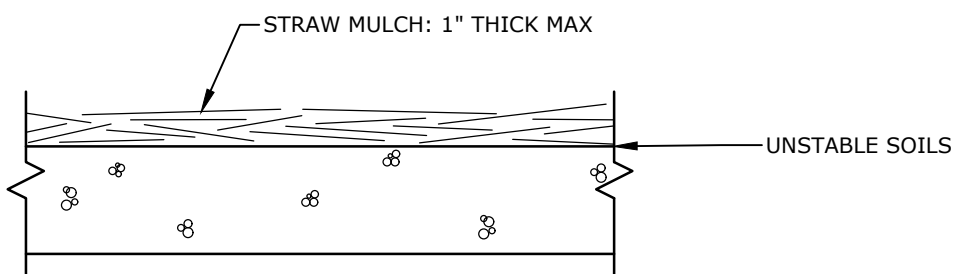

ELEVATION VIEW

UNSTABLE SOILS



STRAW MULCH

DATE:	12/2021
SCALE:	NO SCALE
FIGURE:	A33



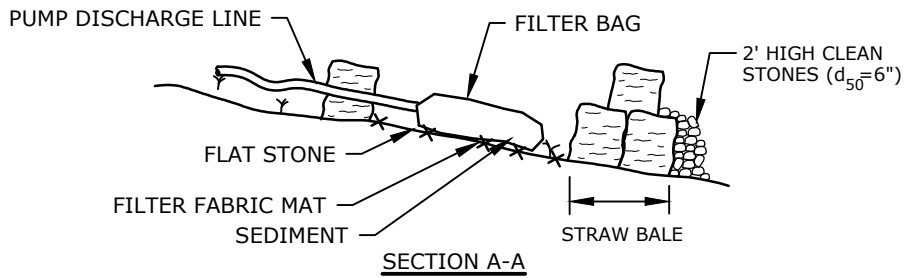

NOTES:

1. LOCATION OF SEDIMENT TRAP SUBJECT TO CONSULTATION WITH EVERSOURCE ENVIRONMENTAL LICENSING AND PERMITTING.
2. SEDIMENT TRAPS OR SETTLING BASINS SHALL BE USED FOR CONSTRUCTION DEWATERING.
3. DISCHARGE AWAY FROM WORK AREA/DEWATERING AREA.

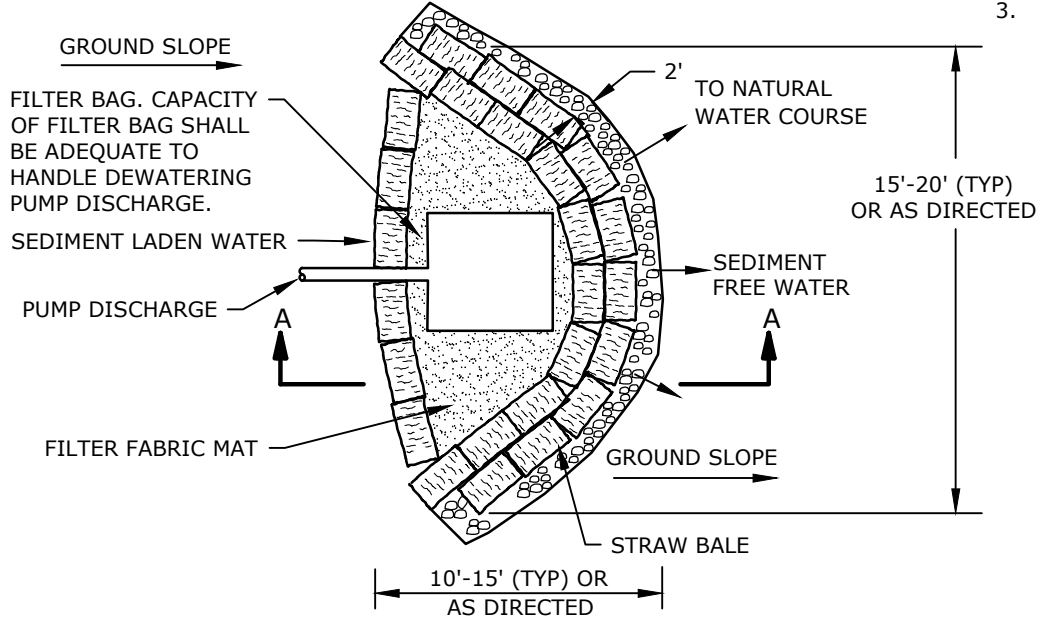

SEDIMENT TRAP

DATE:	12/2021
SCALE:	NO SCALE
FIGURE:	A38



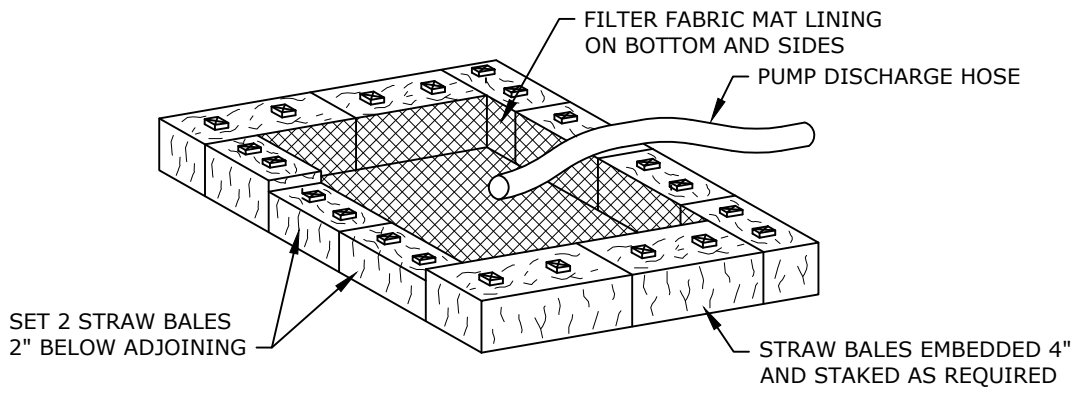

PERSPECTIVE

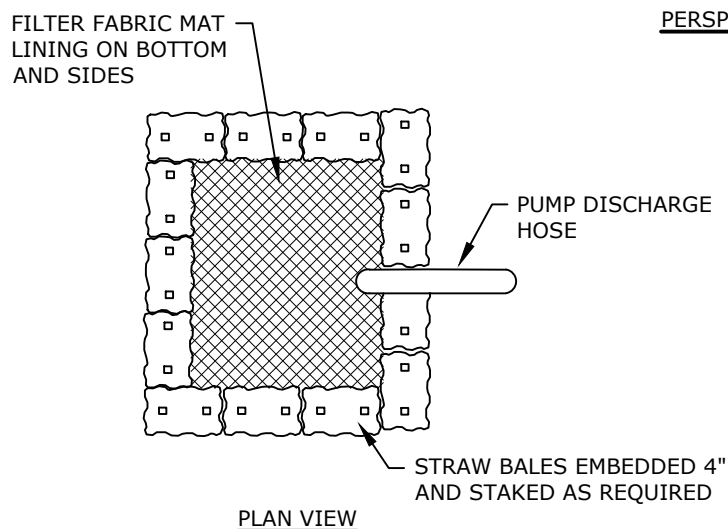

PLAN VIEW

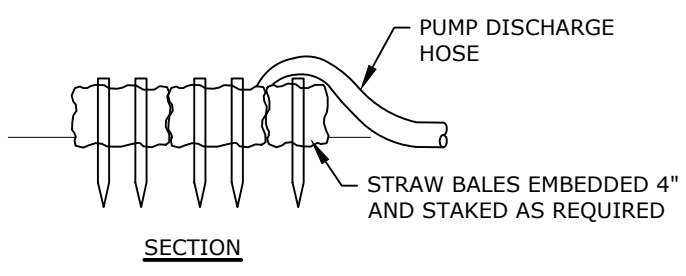

SECTION

NOTE:
 PLACE DEWATERING/PUMPING SETTLING BASINS IN A WELL-VEGETATED AREA, OUTSIDE OF WETLANDS WHENEVER PRACTICABLE.

Dec 15, 2021-3:24pm Plotted By: ASapelli Tighe & Bond, Inc. F:\Projects\E\E5034 Eversource L&P 2019\088 - CT-MA BMP Manual\Drawings_Figures\AutoCAD\Sheet\Dewat_Basin1.dwg

DEWATERING BASIN	
DATE:	12/2021
SCALE:	NO SCALE
FIGURE:	A39



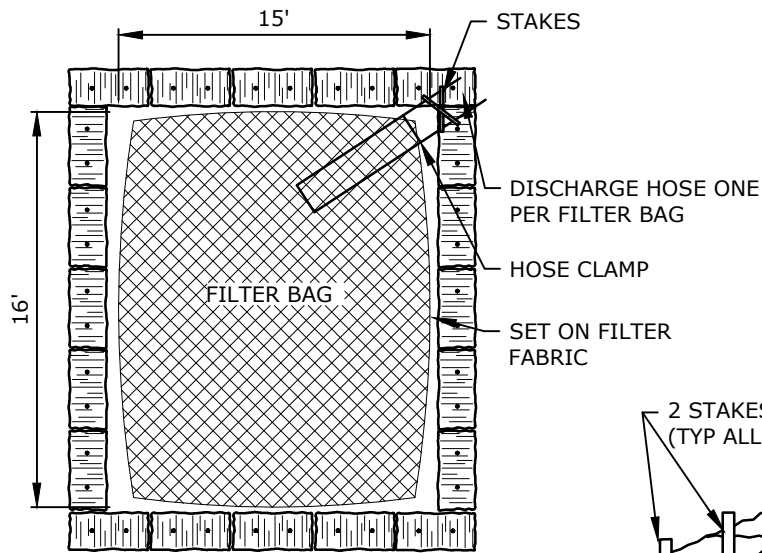

PLAN



SECTION

NOTE:

PLACE FILTER BASINS IN A WELL-VEGETATED AREA, OUTSIDE OF WETLANDS WHENEVER PRACTICABLE.

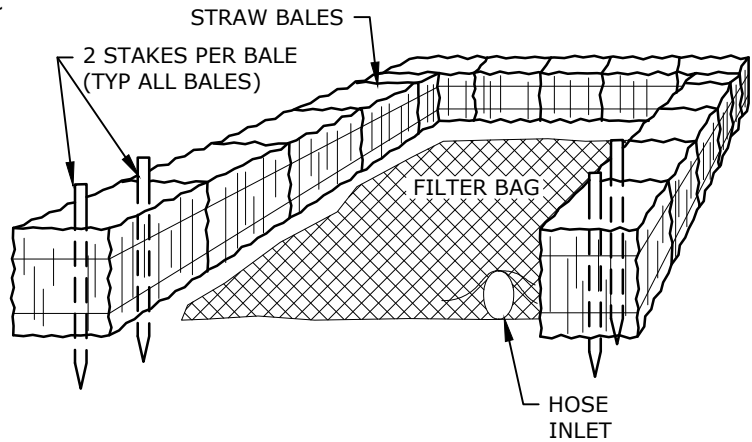

PERSPECTIVE



DEWATERING BASIN
(FILTER BAG)

DATE:	12/2021
SCALE:	NO SCALE
FIGURE:	A40



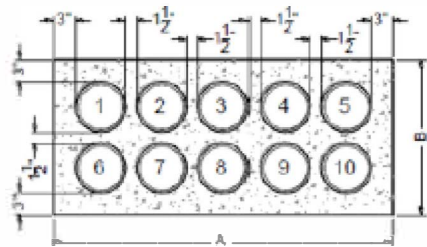
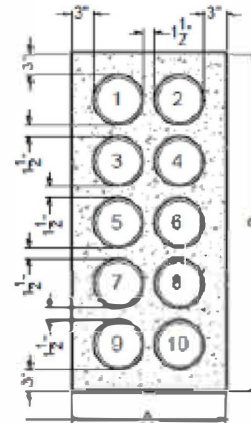
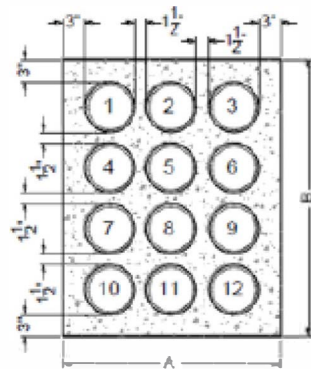

Figure 10A - 10 DUCTS



**Figure 10B - 10 DUCTS
(Alternate)**



**Figure 10C - 12 DUCTS
(Alternate)**

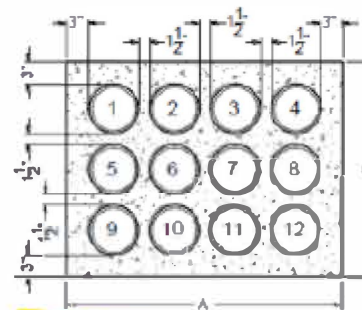

Figure 10D - 12 DUCTS

Figure	Number of Ducts	Dimensions (inches)					
		4 inch Ducts		5 inch Ducts		6 inch Ducts	
		A	B	A	B	A	B
10A	10-DUCTS	34-1/2	16-1/2	39-1/2	18-1/2	45	21
10B	10-DUCTS (alternate)	16-1/2	34-1/2	18-1/2	39-1/2	21	45
10C	12-DUCTS (alternate)	22-1/2	26-1/2	25-1/2	32-1/2	29	37
10D	12-DUCTS	28-1/2	22-1/2	32-1/2	25-1/2	37	29

Figure 10

Duct Bank Cross Section



ATTACHMENT C
Wetland Delineation Report

TECHNICAL MEMORANDUM

TO: James Clancy, Eversource Energy
FROM: Sara Berryman, Wetland Scientist, Kleinfelder
CC: Eileen Piskura, Kleinfelder Environmental Permitting Lead
DATE: October 13, 2022
SUBJECT: Wetland and Watercourse Delineation Memorandum for the Eversource New Bedford Industrial Park Improvements

Kleinfelder Project No.: 20224947.001A

Kleinfelder Inc. (Kleinfelder) has prepared a *Wetland and Watercourse Delineation Memorandum* (memo) as part of the environmental investigation conducted for Eversource Energy in support of planned industrial park improvements. The limit of the investigation is defined by the Study Area, as shown on Figure 1. The following memo summarizes this investigation.

BACKGROUND

Kleinfelder delineated wetlands and watercourses Eversource ROW off Flaherty Drive, New Bedford, MA (Study Area). The Study Area is approximately 25.34 acres within the Town of New Bedford, Bristol County, Massachusetts (MA) and can be located on the United States Geological Survey (USGS) New Bedford North, MA 7.5-minute series topographical quadrangle (National Geographic Society, 2013) (Figure 1).

The Study Area is composed primarily of coniferous forest along the Eversource ROW. The Study Area drains to an unnamed tributary (delineated Stream S02) of the Paskamansett River and is in the Buzzards Bay-Mishaum Point to Gooseberry Neck (HUC12, 010900020402).

Four wetlands and two streams were identified by the U.S. Fish & Wildlife Service (USFWS) National Wetlands Inventory (NWI) within the Study Area, as detailed below and represented on Figure 2.

- Three wetlands are classified as **PFO1E** – Palustrine forested broad-leaved deciduous seasonally flooded/saturated
- One wetland is classified as **PFO1/4E** – Palustrine forested broad-leaved deciduous/needle-leaved evergreen seasonally flooded/saturated
- One stream is classified as **R5UBFx** – Riverine unknown perennial unconsolidated bottom semi-permanently flooded excavated
- One stream is classified as **R5UBH** – Riverine unknown perennial unconsolidated bottom permanently flooded

The Natural Resources Conservation Service (NRCS) web soil survey indicates nine soil map units located within the Study Area. Eight soil map units have been given a hydric soil rating by the NRCS (NRCS, 2018) (**Table 1**).

Table 1. NRCS Mapped Soils Within the Study Area

Soil Map Unit	Description	Hydric Rating By Map Unit (%)
38A	Pipestone loamy sand, 0 to 3 percent slopes	95
51A	Swansea muck, 0 to 1 percent slopes	100
71A	Ridgebury fine sandy loam, 0 to 3 percent slopes, extremely stony	92
73A	Whitman fine sandy loam, 0 to 3 percent slopes, extremely stony	99
260A	Sudbury fine sandy loam, 0 to 3 percent slopes	5
306B	Paxton fine sandy loam, 0 to 8 percent slopes, very stony	4
311B	Woodbridge fine sandy loam, 0 to 8 percent slopes, very stony	8
312B	Woodbridge fine sandy loam, 0 to 8 percent slopes, extremely stony	8
602	Urban land	0

Source: USDA NRCS WebSoil Survey, accessed at: <https://websoilsurvey.sc.egov.usda.gov/App/WebSoilSurvey.aspx>

METHODOLOGY

On February 21st, 2022, and March 1st, 2022, Kleinfelder wetland scientist Sara Berryman and environmental scientist Olivia Footit performed an investigation to identify and delineate wetlands and watercourses potentially regulated under the Massachusetts Wetland Protection Act and the federal Clean Water Act (MA Wetland Protection Act, 1995; Clean Water Act of 1972).

Kleinfelder used the Antecedent Precipitation Tool (U.S. Army Corps of Engineers, 2019) to compare precipitation and temperatures during the field efforts against the 30-year average.

To identify and delineate wetlands, Kleinfelder followed routine wetland determination methodology, as described in the U.S. Army Corps of Engineers (USACE) *Wetland Delineation Manual, Technical Report Y-87-1* (Environmental Laboratory, 1987) using wetland criteria in the *Regional Supplement to the Corps of Engineers Wetland Delineation Manual: Northcentral and Northeast Region (Version 2.0)* (USACE, 2012), and *Delineating Bordering Vegetated Wetlands*

Under the Massachusetts Wetlands Protection Act (MA Department of Environmental Protection [MassDEP], 1995) (BVW Manual). Wetland indicator status for all observed vegetation was noted based upon the National Wetland Plant List version 3.5 (USACE 2020). To identify and delineate watercourses, Kleinfelder performed an evaluation based on typical watercourse characteristics such as defined streambed and streambanks, exclusion of terrestrial vegetation, hydrologically sorted substrate material, and the presence of an ordinary high-water mark (OHWM). Stream categorization follows flow regimes (perennial, intermittent, or ephemeral) defined by the USACE. Wetlands and watercourses were classified following *Classification of Wetlands and Deepwater Habitats of the United States* (FGDC 2013). Kleinfelder mapped aquatic resource boundaries and sample points with a Global Positioning System (GPS) unit.

RESULTS

Weather conditions during the field delineation on 2/22/2022 were sunny with temperatures around 52 degrees Fahrenheit. Weather conditions during the field delineation on 3/01/2022 were overcast with temperatures around 40 degrees Fahrenheit. **Table 2** details the normal climate condition exhibited during the delineation.

Table 2. Precipitation Analysis

Date	Previous 48 hr. Precipitation (in.) ¹	High Temp (°F) ¹	APT Condition ²	Season ²	Palmer Drought Severity Index ²
2/22/2022	0	55	Normal Conditions	Wet	Moderate Wetness
3/01/2022	0	44	Wetter than normal	Wet	Mild Wetness

¹Data taken from the KMANEWBE88 Station. ²Output from USACE Antecedent Precipitation Tool (v1.0.19).

Five palustrine forested (PFO) wetlands, two palustrine emergent (PEM) wetlands, one palustrine scrub-shrub (PSS) wetland, and two perennial streams were identified and delineated within the Study Area (**Figure 3**). USACE Wetland Determination Data Forms, MassDEP Bordering Vegetated Wetland Forms, and photographs are provided in Appendices A and B.

Table 3. Delineated Wetland Features

Wetland ID	Feature Type	NWI Classification	MA WPA Resource Type	Area (square feet)
W01	Wetland	PFO	BVW	18,681.5
W02	Wetland	PFO	BVW	37,239.2
W03	Wetland	PEM	BVW	363.6
W04	Wetland	PEM	BVW	434.8
W05	Wetland	PSS	BVW	16,655.3
W06	Wetland	PFO	BVW	44,621.1
W07	Wetland	PFO	BVW	34,820.4
W08	Wetland	PFO	BVW	32,143

Table 4. Delineated Stream Features

Stream ID	Cowardin Classification	Flow Regime	OHWB (feet)
S01	R2UB2	Perennial	2
S02	R2RB2	Perennial	2

SUMMARY

Kleinfelder conducted wetland and watercourse investigations on both February 22, and March 1st of 2022, for Eversource in support of the industrial park improvements within the Town of New Bedford, Bristol County, Massachusetts. Four PFO wetlands and two perennial streams were identified and delineated within the Study Area.

LIMITATIONS

- This investigation was limited to the Study Area shown herein. Kleinfelder did not examine areas outside of the Study Area, thus no information is provided regarding the presence or absence of regulated wetlands and watercourses outside of the Study Area.
- This investigation was conducted on the dates indicated. Human-induced or natural changes at the Study Area may occur after this date which may cause changes in the presence and extent of regulated wetlands and watercourses.
- The findings of the Study Area investigation completed by Kleinfelder were limited to the date of the investigation, and this report reflects the conditions at that time. In circumstances where a site has been developed prior to the Study Area investigation, the presence or absence of pre-construction wetlands or watercourses and their estimated extents within the Study Area is beyond the scope of this report.

REFERENCES

- Clean Water Act of 1972, 33 U.S.C. § 1251 et seq. 2002. Accessed at <https://www.epa.gov/sites/production/files/2017-08/documents/federal-water-pollution-control-act-508full.pdf>.
- Environmental Laboratory. 1987. Corps of Engineers Wetlands Delineation Manual. Technical Report Y-87-1. U.S. Army Engineer Waterways Experiment Station, Vicksburg, MS.
- Federal Geographic Data Committee (FGDC). 2013. Classification of wetlands and deepwater habitats of the United States. FGDC-STD-004-2013. Second Edition. Wetlands Subcommittee, Federal Geographic Data Committee and U.S. Fish and Wildlife Service, Washington D.C.
- Massachusetts Wetlands Protection Act, 310 CMR 10.00. 1995. Accessed at <https://www.mass.gov/regulations/310-CMR-1000-wetlands-protection-act-regulations>.
- Massachusetts Department of Environmental Protection (MassDEP). 1995. Delineating Bordering Vegetated Wetlands Under the Massachusetts Wetlands Protection Act. Accessed at: <https://www.mass.gov/files/documents/2016/08/pn/bvwmanua.pdf>.
- Natural Resources Conservation Service (NRCS). 2021. Web Soil Survey. Accessed at: <https://websoilsurvey.sc.egov.usda.gov/App/WebSoilSurvey.aspx>.
- National Geographic Society. 2013. Seamless Layer 2013 (Topo Source: Seamless Digital Raster Graphic-N.P.S. Natural Physical Map & U.S.G.S. Topographic Map i-cubed USGS Quad: Greenfield, MA).
- U.S. Army Corps of Engineers (USACE). 2019. Antecedent Precipitation Tool. V1.0.19. Available online at the following link: <https://github.com/jDeters-USACE/Antecedent-Precipitation-Tool/releases/tag/v1.0.19>.
- U.S. Army Corps of Engineers (USACE). 2020. National Wetland Plant List, version 3.5. <http://wetland-plants.usace.army.mil/> U.S. Army Corps of Engineers Engineer Research and Development Center, Cold Regions Research and Engineering Laboratory. Hanover, NH.
- U.S. Fish and Wildlife Service (USFWS) 2018. National Wetlands Inventory website. U.S. Department of the Interior, Fish and Wildlife Service, Washington, D.C. Accessed at <http://www.fws.gov/wetlands>.
- U.S. Army Corps of Engineers (USACE). 2012. Regional Supplement to the Corps of Engineers Wetland Delineation Manual: Northcentral and Northeast Region (Version 2.0), ed. J. S. Wakeley, R. W. Lichvar, C. V. Noble, and J. F. Berkowitz. ERDC/EL TR-12-1. Vicksburg, MS: U.S. Army Engineer Research and Development Center.

FIGURES

Soil Map—Bristol County, Massachusetts, Southern Part
(New Bedford Industrial Park)



Soil Map may not be valid at this scale.

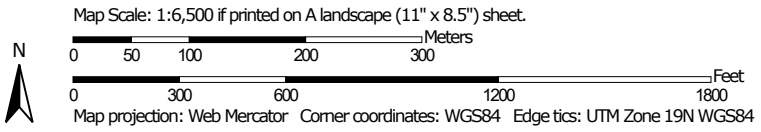

Soil Map—Bristol County, Massachusetts, Southern Part
(New Bedford Industrial Park)

MAP LEGEND

Area of Interest (AOI)

 Area of Interest (AOI)



















Soils







 Soil Map Unit Polygons

 Soil Map Unit Lines

 Soil Map Unit Points

Special Point Features





-  Blowout
-  Borrow Pit
-  Clay Spot
-  Closed Depression
-  Gravel Pit
-  Gravelly Spot
-  Landfill
-  Lava Flow
-  Marsh or swamp
-  Mine or Quarry
-  Miscellaneous Water
-  Perennial Water
-  Rock Outcrop
-  Saline Spot
-  Sandy Spot
-  Severely Eroded Spot
-  Sinkhole
-  Slide or Slip
-  Sodic Spot

-  Spoil Area
-  Stony Spot
-  Very Stony Spot
-  Wet Spot
-  Other
-  Special Line Features

Water Features

 Streams and Canals

Transportation

-  Rails
-  Interstate Highways
-  US Routes
-  Major Roads
-  Local Roads

Background

 Aerial Photography

MAP INFORMATION

The soil surveys that comprise your AOI were mapped at 1:20,000.

Warning: Soil Map may not be valid at this scale.

Enlargement of maps beyond the scale of mapping can cause misunderstanding of the detail of mapping and accuracy of soil line placement. The maps do not show the small areas of contrasting soils that could have been shown at a more detailed scale.

Please rely on the bar scale on each map sheet for map measurements.

Source of Map: Natural Resources Conservation Service
Web Soil Survey URL:
Coordinate System: Web Mercator (EPSG:3857)

Maps from the Web Soil Survey are based on the Web Mercator projection, which preserves direction and shape but distorts distance and area. A projection that preserves area, such as the Albers equal-area conic projection, should be used if more accurate calculations of distance or area are required.

This product is generated from the USDA-NRCS certified data as of the version date(s) listed below.

Soil Survey Area: Bristol County, Massachusetts, Southern Part
Survey Area Data: Version 15, Sep 2, 2021

Soil map units are labeled (as space allows) for map scales 1:50,000 or larger.

Date(s) aerial images were photographed: Sep 26, 2020—Oct 15, 2020

The orthophoto or other base map on which the soil lines were compiled and digitized probably differs from the background imagery displayed on these maps. As a result, some minor shifting of map unit boundaries may be evident.

Map Unit Legend

Map Unit Symbol	Map Unit Name	Acres in AOI	Percent of AOI
38A	Pipestone loamy sand, 0 to 3 percent slopes	8.9	12.3%
39A	Scarboro mucky fine sandy loam, 0 to 3 percent slopes	3.5	4.9%
51A	Swansea muck, 0 to 1 percent slopes	17.5	24.1%
52A	Freetown muck, 0 to 1 percent slopes	0.4	0.5%
71A	Ridgebury fine sandy loam, 0 to 3 percent slopes, extremely stony	0.9	1.3%
73A	Whitman fine sandy loam, 0 to 3 percent slopes, extremely stony	6.6	9.1%
260A	Sudbury fine sandy loam, 0 to 3 percent slopes	25.0	34.4%
306B	Paxton fine sandy loam, 0 to 8 percent slopes, very stony	0.0	0.0%
311B	Woodbridge fine sandy loam, 0 to 8 percent slopes, very stony	5.4	7.4%
312B	Woodbridge fine sandy loam, 0 to 8 percent slopes, extremely stony	1.8	2.5%
602	Urban land	2.6	3.6%
Totals for Area of Interest		72.6	100.0%

APPENDIX A

FIELD DATA FORMS

WETLAND DETERMINATION DATA FORM – Northcentral and Northeast Region

Project/Site: New Bedford Industrial Park Infrastructure Installation City/County: New Bedford Sampling Date: 2/21/2022
 Applicant/Owner: Eversource Energy State: MA Sampling Point: 1
 Investigator(s): Sara Berryman, Olivia Footit Section, Township, Range: N/A
 Landform (hillside, terrace, etc.): Terrace Local relief (concave, convex, none): None Slope (%): 0
 Subregion (LRR or MLRA): LRR R, MLRA 144A Lat: 41.718682 Long: -70.959925 Datum: WGS
 Soil Map Unit Name: Sudbury fine sandy loam, 0 to 3 percent slopes NWI classification: N/A

Are climatic / hydrologic conditions on the site typical for this time of year? Yes No (If no, explain in Remarks.)
 Are Vegetation , Soil , or Hydrology significantly disturbed? Are "Normal Circumstances" present? Yes No
 Are Vegetation , Soil , or Hydrology naturally problematic? (If needed, explain any answers in Remarks.)

SUMMARY OF FINDINGS – Attach site map showing sampling point locations, transects, important features, etc.

Hydrophytic Vegetation Present?	Yes <input type="checkbox"/>	No <input checked="" type="checkbox"/>	Is the Sampled Area within a Wetland? Yes <input type="checkbox"/> No <input checked="" type="checkbox"/> If yes, optional Wetland Site ID: _____
Hydric Soil Present?	Yes <input type="checkbox"/>	No <input checked="" type="checkbox"/>	
Wetland Hydrology Present?	Yes <input type="checkbox"/>	No <input checked="" type="checkbox"/>	
Remarks: (Explain alternative procedures here or in a separate report.)			

HYDROLOGY

Wetland Hydrology Indicators: <u>Primary Indicators (minimum of one is required; check all that apply)</u> <input type="checkbox"/> Surface Water (A1) <input type="checkbox"/> Water-Stained Leaves (B9) <input type="checkbox"/> High Water Table (A2) <input type="checkbox"/> Aquatic Fauna (B13) <input type="checkbox"/> Saturation (A3) <input type="checkbox"/> Marl Deposits (B15) <input type="checkbox"/> Water Marks (B1) <input type="checkbox"/> Hydrogen Sulfide Odor (C1) <input type="checkbox"/> Sediment Deposits (B2) <input type="checkbox"/> Oxidized Rhizospheres on Living Roots (C3) <input type="checkbox"/> Drift Deposits (B3) <input type="checkbox"/> Presence of Reduced Iron (C4) <input type="checkbox"/> Algal Mat or Crust (B4) <input type="checkbox"/> Recent Iron Reduction in Tilled Soils (C6) <input type="checkbox"/> Iron Deposits (B5) <input type="checkbox"/> Thin Muck Surface (C7) <input type="checkbox"/> Inundation Visible on Aerial Imagery (B7) <input type="checkbox"/> Other (Explain in Remarks) <input type="checkbox"/> Sparsely Vegetated Concave Surface (B8)	<u>Secondary Indicators (minimum of two required)</u> <input type="checkbox"/> Surface Soil Cracks (B6) <input type="checkbox"/> Drainage Patterns (B10) <input type="checkbox"/> Moss Trim Lines (B16) <input type="checkbox"/> Dry-Season Water Table (C2) <input type="checkbox"/> Crayfish Burrows (C8) <input type="checkbox"/> Saturation Visible on Aerial Imagery (C9) <input type="checkbox"/> Stunted or Stressed Plants (D1) <input type="checkbox"/> Geomorphic Position (D2) <input type="checkbox"/> Shallow Aquitard (D3) <input type="checkbox"/> Microtopographic Relief (D4) <input type="checkbox"/> FAC-Neutral Test (D5)
Field Observations: Surface Water Present? Yes <input type="checkbox"/> No <input checked="" type="checkbox"/> Depth (inches): _____ Water Table Present? Yes <input type="checkbox"/> No <input checked="" type="checkbox"/> Depth (inches): _____ Saturation Present? Yes <input type="checkbox"/> No <input checked="" type="checkbox"/> Depth (inches): _____ (includes capillary fringe)	Wetland Hydrology Present? Yes <input type="checkbox"/> No <input checked="" type="checkbox"/>
Describe Recorded Data (stream gauge, monitoring well, aerial photos, previous inspections), if available:	
Remarks:	

VEGETATION – Use scientific names of plants.

Sampling Point: 1

	Absolute % Cover	Dominant Species?	Indicator Status
Tree Stratum (Plot size: _____)			
1. <u>Pinus strobus</u>	20	Yes	FACU
2. <u>Acer rubrum</u>	10	Yes	FAC
3. _____			
4. _____			
5. _____			
6. _____			
7. _____			
	30	=Total Cover	
Sapling/Shrub Stratum (Plot size: _____)			
1. <u>Kalmia latifolia</u>	15	Yes	FACU
2. <u>Tsuga canadensis</u>	5	No	FACU
3. <u>Ilex aquifolium</u>	15	Yes	FACU
4. _____			
5. _____			
6. _____			
7. _____			
	35	=Total Cover	
Herb Stratum (Plot size: _____)			
1. _____			
2. _____			
3. _____			
4. _____			
5. _____			
6. _____			
7. _____			
8. _____			
9. _____			
10. _____			
11. _____			
12. _____			
		=Total Cover	
Woody Vine Stratum (Plot size: _____)			
1. _____			
2. _____			
3. _____			
4. _____			
		=Total Cover	

Dominance Test worksheet:

Number of Dominant Species That Are OBL, FACW, or FAC: 1 (A)

Total Number of Dominant Species Across All Strata: 4 (B)

Percent of Dominant Species That Are OBL, FACW, or FAC: 25.0% (A/B)

Prevalence Index worksheet:

Total % Cover of:	Multiply by:
OBL species <u>0</u>	x 1 = <u>0</u>
FACW species <u>0</u>	x 2 = <u>0</u>
FAC species <u>10</u>	x 3 = <u>30</u>
FACU species <u>55</u>	x 4 = <u>220</u>
UPL species <u>0</u>	x 5 = <u>0</u>
Column Totals: <u>65</u> (A)	<u>250</u> (B)
Prevalence Index = B/A = <u>3.85</u>	

- Hydrophytic Vegetation Indicators:**
- 1 - Rapid Test for Hydrophytic Vegetation
 - 2 - Dominance Test is >50%
 - 3 - Prevalence Index is ≤3.0¹
 - 4 - Morphological Adaptations¹ (Provide supporting data in Remarks or on a separate sheet)
 - Problematic Hydrophytic Vegetation¹ (Explain)
- ¹Indicators of hydric soil and wetland hydrology must be present, unless disturbed or problematic.

Definitions of Vegetation Strata:

Tree – Woody plants 3 in. (7.6 cm) or more in diameter at breast height (DBH), regardless of height.

Sapling/shrub – Woody plants less than 3 in. DBH and greater than or equal to 3.28 ft (1 m) tall.

Herb – All herbaceous (non-woody) plants, regardless of size, and woody plants less than 3.28 ft tall.

Woody vines – All woody vines greater than 3.28 ft in height.

Hydrophytic Vegetation Present? Yes No X

Remarks: (Include photo numbers here or on a separate sheet.)

SOIL

Sampling Point: 1

Profile Description: (Describe to the depth needed to document the indicator or confirm the absence of indicators.)

Depth (inches)	Matrix		Redox Features				Texture	Remarks
	Color (moist)	%	Color (moist)	%	Type ¹	Loc ²		
0-2	10YR 3/2	100					Loamy/Clayey	
2-8	10YR 4/3	100					Sandy	Cobbles present

¹Type: C=Concentration, D=Depletion, RM=Reduced Matrix, CS=Covered or Coated Sand Grains. ²Location: PL=Pore Lining, M=Matrix.

Hydric Soil Indicators:		Indicators for Problematic Hydric Soils³:	
<input type="checkbox"/> Histosol (A1)	<input type="checkbox"/> Polyvalue Below Surface (S8) (LRR R, MLRA 149B)	<input type="checkbox"/> 2 cm Muck (A10) (LRR K, L, MLRA 149B)	
<input type="checkbox"/> Histic Epipedon (A2)	<input type="checkbox"/> Thin Dark Surface (S9) (LRR R, MLRA 149B)	<input type="checkbox"/> Coast Prairie Redox (A16) (LRR K, L, R)	
<input type="checkbox"/> Black Histic (A3)	<input type="checkbox"/> High Chroma Sands (S11) (LRR K, L)	<input type="checkbox"/> 5 cm Mucky Peat or Peat (S3) (LRR K, L, R)	
<input type="checkbox"/> Hydrogen Sulfide (A4)	<input type="checkbox"/> Loamy Mucky Mineral (F1) (LRR K, L)	<input type="checkbox"/> Polyvalue Below Surface (S8) (LRR K, L)	
<input type="checkbox"/> Stratified Layers (A5)	<input type="checkbox"/> Loamy Gleyed Matrix (F2)	<input type="checkbox"/> Thin Dark Surface (S9) (LRR K, L)	
<input type="checkbox"/> Depleted Below Dark Surface (A11)	<input type="checkbox"/> Depleted Matrix (F3)	<input type="checkbox"/> Iron-Manganese Masses (F12) (LRR K, L, R)	
<input type="checkbox"/> Thick Dark Surface (A12)	<input type="checkbox"/> Redox Dark Surface (F6)	<input type="checkbox"/> Piedmont Floodplain Soils (F19) (MLRA 149B)	
<input type="checkbox"/> Sandy Mucky Mineral (S1)	<input type="checkbox"/> Depleted Dark Surface (F7)	<input type="checkbox"/> Mesic Spodic (TA6) (MLRA 144A, 145, 149B)	
<input type="checkbox"/> Sandy Gleyed Matrix (S4)	<input type="checkbox"/> Redox Depressions (F8)	<input type="checkbox"/> Red Parent Material (F21)	
<input type="checkbox"/> Sandy Redox (S5)	<input type="checkbox"/> Marl (F10) (LRR K, L)	<input type="checkbox"/> Very Shallow Dark Surface (TF12)	
<input type="checkbox"/> Stripped Matrix (S6)		<input type="checkbox"/> Other (Explain in Remarks)	
<input type="checkbox"/> Dark Surface (S7)			

³Indicators of hydrophytic vegetation and wetland hydrology must be present, unless disturbed or problematic.

Restrictive Layer (if observed): Type: <u>Roots</u> Depth (inches): <u>8</u>	Hydric Soil Present? Yes <input type="checkbox"/> No <input checked="" type="checkbox"/>
---	---

Remarks:
This data form is revised from Northcentral and Northeast Regional Supplement Version 2.0 to reflect the NRCS Field Indicators of Hydric Soils version 7.0 March 2013 Errata. (http://www.nrcs.usda.gov/Internet/FSE_DOCUMENTS/nrcs142p2_051293.docx)

WETLAND DETERMINATION DATA FORM – Northcentral and Northeast Region

Project/Site: New Bedford Industrial Park Infrastructure Installation City/County: New Bedford Sampling Date: 2/24/2022
 Applicant/Owner: Eversource Energy State: MA Sampling Point: 2
 Investigator(s): Sara Berryman, Olivia Footit Section, Township, Range: _____
 Landform (hillside, terrace, etc.): Terrace Local relief (concave, convex, none): Concave Slope (%): 1
 Subregion (LRR or MLRA): LRR R, MLRA 144A Lat: 41.718847 Long: -70.959504 Datum: WGS
 Soil Map Unit Name: Pipestone loamy sand, 0 to 3 percent slopes NWI classification: PFO4

Are climatic / hydrologic conditions on the site typical for this time of year? Yes X No _____ (If no, explain in Remarks.)
 Are Vegetation _____, Soil _____, or Hydrology _____ significantly disturbed? Are "Normal Circumstances" present? Yes X No _____
 Are Vegetation _____, Soil _____, or Hydrology _____ naturally problematic? (If needed, explain any answers in Remarks.)

SUMMARY OF FINDINGS – Attach site map showing sampling point locations, transects, important features, etc.

Hydrophytic Vegetation Present?	Yes _____	No <u>X</u>	Is the Sampled Area within a Wetland? Yes <u>X</u> No _____ If yes, optional Wetland Site ID: <u>W01</u>
Hydric Soil Present?	Yes <u>X</u>	No _____	
Wetland Hydrology Present?	Yes <u>X</u>	No _____	
Remarks: (Explain alternative procedures here or in a separate report.)			

HYDROLOGY

Wetland Hydrology Indicators: <u>Primary Indicators (minimum of one is required; check all that apply)</u> _____ Surface Water (A1) _____ Water-Stained Leaves (B9) <u>X</u> High Water Table (A2) _____ Aquatic Fauna (B13) <u>X</u> Saturation (A3) _____ Marl Deposits (B15) _____ Water Marks (B1) _____ Hydrogen Sulfide Odor (C1) _____ Sediment Deposits (B2) _____ Oxidized Rhizospheres on Living Roots (C3) _____ Drift Deposits (B3) _____ Presence of Reduced Iron (C4) _____ Algal Mat or Crust (B4) _____ Recent Iron Reduction in Tilled Soils (C6) _____ Iron Deposits (B5) _____ Thin Muck Surface (C7) _____ Inundation Visible on Aerial Imagery (B7) _____ Other (Explain in Remarks) _____ Sparsely Vegetated Concave Surface (B8)	<u>Secondary Indicators (minimum of two required)</u> _____ Surface Soil Cracks (B6) _____ Drainage Patterns (B10) _____ Moss Trim Lines (B16) _____ Dry-Season Water Table (C2) _____ Crayfish Burrows (C8) _____ Saturation Visible on Aerial Imagery (C9) _____ Stunted or Stressed Plants (D1) _____ Geomorphic Position (D2) _____ Shallow Aquitard (D3) _____ Microtopographic Relief (D4) _____ FAC-Neutral Test (D5)
--	---

Field Observations: Surface Water Present? Yes _____ No <u>X</u> Depth (inches): _____ Water Table Present? Yes <u>X</u> No _____ Depth (inches): <u>3</u> Saturation Present? Yes <u>X</u> No _____ Depth (inches): <u>0</u> (includes capillary fringe)	Wetland Hydrology Present? Yes <u>X</u> No _____
--	---

Describe Recorded Data (stream gauge, monitoring well, aerial photos, previous inspections), if available:

Remarks:

VEGETATION – Use scientific names of plants.

Sampling Point: 2

	Absolute % Cover	Dominant Species?	Indicator Status
Tree Stratum (Plot size: _____)			
1. <u>Pinus strobus</u>	40	Yes	FACU
2. <u>Acer saccharinum</u>	10	Yes	FACW
3. _____			
4. _____			
5. _____			
6. _____			
7. _____			
	50	=Total Cover	
Sapling/Shrub Stratum (Plot size: _____)			
1. <u>Berberis thunbergii</u>	15	Yes	FACU
2. <u>Cornus alba</u>	30	Yes	FACW
3. <u>Ilex aquifolium</u>	20	Yes	FACU
4. _____			
5. _____			
6. _____			
7. _____			
	65	=Total Cover	
Herb Stratum (Plot size: _____)			
1. _____			
2. _____			
3. _____			
4. _____			
5. _____			
6. _____			
7. _____			
8. _____			
9. _____			
10. _____			
11. _____			
12. _____			
		=Total Cover	
Woody Vine Stratum (Plot size: _____)			
1. <u>Smilax</u>	20	Yes	
2. _____			
3. _____			
4. _____			
	20	=Total Cover	

Dominance Test worksheet:

Number of Dominant Species That Are OBL, FACW, or FAC: 2 (A)

Total Number of Dominant Species Across All Strata: 6 (B)

Percent of Dominant Species That Are OBL, FACW, or FAC: 33.3% (A/B)

Prevalence Index worksheet:

Total % Cover of:	Multiply by:
OBL species <u>0</u>	x 1 = <u>0</u>
FACW species <u>40</u>	x 2 = <u>80</u>
FAC species <u>0</u>	x 3 = <u>0</u>
FACU species <u>75</u>	x 4 = <u>300</u>
UPL species <u>0</u>	x 5 = <u>0</u>
Column Totals: <u>115</u> (A)	<u>380</u> (B)
Prevalence Index = B/A = <u>3.30</u>	

- Hydrophytic Vegetation Indicators:**
- 1 - Rapid Test for Hydrophytic Vegetation
 - 2 - Dominance Test is >50%
 - 3 - Prevalence Index is ≤3.0¹
 - 4 - Morphological Adaptations¹ (Provide supporting data in Remarks or on a separate sheet)
 - Problematic Hydrophytic Vegetation¹ (Explain)
- ¹Indicators of hydric soil and wetland hydrology must be present, unless disturbed or problematic.

Definitions of Vegetation Strata:

Tree – Woody plants 3 in. (7.6 cm) or more in diameter at breast height (DBH), regardless of height.

Sapling/shrub – Woody plants less than 3 in. DBH and greater than or equal to 3.28 ft (1 m) tall.

Herb – All herbaceous (non-woody) plants, regardless of size, and woody plants less than 3.28 ft tall.

Woody vines – All woody vines greater than 3.28 ft in height.

Hydrophytic Vegetation Present? Yes No X

Remarks: (Include photo numbers here or on a separate sheet.)

WETLAND DETERMINATION DATA FORM – Northcentral and Northeast Region

Project/Site: New Bedford Industrial Park Infrastructure Installation City/County: New Bedford Sampling Date: 2/21/2022
 Applicant/Owner: Eversource Energy State: MA Sampling Point: 3
 Investigator(s): Sara Berryman, Olivia Footit Section, Township, Range: _____
 Landform (hillside, terrace, etc.): Terrace Local relief (concave, convex, none): None Slope (%): 0
 Subregion (LRR or MLRA): LRR R, MLRA 144A Lat: 41.718705 Long: -70.960809 Datum: WGS
 Soil Map Unit Name: Swansea muck, 0 to 1 percent slopes NWI classification: PFO4

Are climatic / hydrologic conditions on the site typical for this time of year? Yes X No _____ (If no, explain in Remarks.)
 Are Vegetation _____, Soil _____, or Hydrology _____ significantly disturbed? Are "Normal Circumstances" present? Yes X No _____
 Are Vegetation _____, Soil _____, or Hydrology _____ naturally problematic? (If needed, explain any answers in Remarks.)

SUMMARY OF FINDINGS – Attach site map showing sampling point locations, transects, important features, etc.

Hydrophytic Vegetation Present?	Yes _____	No <u>X</u>	Is the Sampled Area within a Wetland? Yes <u>X</u> No _____ If yes, optional Wetland Site ID: <u>W02</u>
Hydric Soil Present?	Yes <u>X</u>	No _____	
Wetland Hydrology Present?	Yes <u>X</u>	No _____	
Remarks: (Explain alternative procedures here or in a separate report.)			

HYDROLOGY

Wetland Hydrology Indicators: <u>Primary Indicators (minimum of one is required; check all that apply)</u> _____ Surface Water (A1) <u>X</u> Water-Stained Leaves (B9) <u>X</u> High Water Table (A2) _____ Aquatic Fauna (B13) <u>X</u> Saturation (A3) _____ Marl Deposits (B15) _____ Water Marks (B1) _____ Hydrogen Sulfide Odor (C1) _____ Sediment Deposits (B2) _____ Oxidized Rhizospheres on Living Roots (C3) _____ Drift Deposits (B3) _____ Presence of Reduced Iron (C4) _____ Algal Mat or Crust (B4) _____ Recent Iron Reduction in Tilled Soils (C6) _____ Iron Deposits (B5) _____ Thin Muck Surface (C7) _____ Inundation Visible on Aerial Imagery (B7) _____ Other (Explain in Remarks) _____ Sparsely Vegetated Concave Surface (B8)	<u>Secondary Indicators (minimum of two required)</u> _____ Surface Soil Cracks (B6) _____ Drainage Patterns (B10) _____ Moss Trim Lines (B16) _____ Dry-Season Water Table (C2) _____ Crayfish Burrows (C8) _____ Saturation Visible on Aerial Imagery (C9) _____ Stunted or Stressed Plants (D1) _____ Geomorphic Position (D2) _____ Shallow Aquitard (D3) _____ Microtopographic Relief (D4) _____ FAC-Neutral Test (D5)
--	---

Field Observations: Surface Water Present? Yes _____ No <u>X</u> Depth (inches): _____ Water Table Present? Yes <u>X</u> No _____ Depth (inches): <u>4</u> Saturation Present? Yes <u>X</u> No _____ Depth (inches): <u>0</u> (includes capillary fringe)	Wetland Hydrology Present? Yes <u>X</u> No _____
--	---

Describe Recorded Data (stream gauge, monitoring well, aerial photos, previous inspections), if available:

Remarks:

VEGETATION – Use scientific names of plants.

Sampling Point: 3

	Absolute % Cover	Dominant Species?	Indicator Status
Tree Stratum (Plot size: _____)			
1. <u><i>Pinus strobus</i></u>	<u>40</u>	<u>Yes</u>	<u>FACU</u>
2. <u><i>Acer rubrum</i></u>	<u>10</u>	<u>Yes</u>	<u>FAC</u>
3. _____	_____	_____	_____
4. _____	_____	_____	_____
5. _____	_____	_____	_____
6. _____	_____	_____	_____
7. _____	_____	_____	_____
	<u>50</u>	=Total Cover	
Sapling/Shrub Stratum (Plot size: _____)			
1. <u><i>Kalmia latifolia</i></u>	<u>5</u>	<u>Yes</u>	<u>FACU</u>
2. <u><i>Cornus alba</i></u>	<u>15</u>	<u>Yes</u>	<u>FACW</u>
3. _____	_____	_____	_____
4. _____	_____	_____	_____
5. _____	_____	_____	_____
6. _____	_____	_____	_____
7. _____	_____	_____	_____
	<u>20</u>	=Total Cover	
Herb Stratum (Plot size: _____)			
1. _____	_____	_____	_____
2. _____	_____	_____	_____
3. _____	_____	_____	_____
4. _____	_____	_____	_____
5. _____	_____	_____	_____
6. _____	_____	_____	_____
7. _____	_____	_____	_____
8. _____	_____	_____	_____
9. _____	_____	_____	_____
10. _____	_____	_____	_____
11. _____	_____	_____	_____
12. _____	_____	_____	_____
	_____	=Total Cover	
Woody Vine Stratum (Plot size: _____)			
1. _____	_____	_____	_____
2. _____	_____	_____	_____
3. _____	_____	_____	_____
4. _____	_____	_____	_____
	_____	=Total Cover	

Dominance Test worksheet:

Number of Dominant Species That Are OBL, FACW, or FAC: 2 (A)

Total Number of Dominant Species Across All Strata: 4 (B)

Percent of Dominant Species That Are OBL, FACW, or FAC: 50.0% (A/B)

Prevalence Index worksheet:

Total % Cover of:	Multiply by:
OBL species <u>0</u>	x 1 = <u>0</u>
FACW species <u>15</u>	x 2 = <u>30</u>
FAC species <u>10</u>	x 3 = <u>30</u>
FACU species <u>45</u>	x 4 = <u>180</u>
UPL species <u>0</u>	x 5 = <u>0</u>
Column Totals: <u>70</u> (A)	<u>240</u> (B)
Prevalence Index = B/A = <u>3.43</u>	

- Hydrophytic Vegetation Indicators:**
- 1 - Rapid Test for Hydrophytic Vegetation
 - 2 - Dominance Test is >50%
 - 3 - Prevalence Index is ≤3.0¹
 - 4 - Morphological Adaptations¹ (Provide supporting data in Remarks or on a separate sheet)
 - Problematic Hydrophytic Vegetation¹ (Explain)
- ¹Indicators of hydric soil and wetland hydrology must be present, unless disturbed or problematic.

Definitions of Vegetation Strata:

Tree – Woody plants 3 in. (7.6 cm) or more in diameter at breast height (DBH), regardless of height.

Sapling/shrub – Woody plants less than 3 in. DBH and greater than or equal to 3.28 ft (1 m) tall.

Herb – All herbaceous (non-woody) plants, regardless of size, and woody plants less than 3.28 ft tall.

Woody vines – All woody vines greater than 3.28 ft in height.

Hydrophytic Vegetation Present? Yes No X

Remarks: (Include photo numbers here or on a separate sheet.)

SOIL

Sampling Point: 3

Profile Description: (Describe to the depth needed to document the indicator or confirm the absence of indicators.)								
Depth (inches)	Matrix		Redox Features				Texture	Remarks
	Color (moist)	%	Color (moist)	%	Type ¹	Loc ²		
0-3	10YR 2/1	100					Mucky Peat	
3-5	10YR 2/2	100					Loamy/Clayey	
5-9	10YR 2/2	93	7.5YR 4/6	5	C	M	Loamy/Clayey	Prominent redox concentrations
			10YR 5/6	2	C	M		Prominent redox concentrations
9-12	10YR 5/6	93	10YR 5/3	2	D	M	Loamy/Clayey	
			5YR 4/6	5	C	M		Distinct redox concentrations

¹Type: C=Concentration, D=Depletion, RM=Reduced Matrix, CS=Covered or Coated Sand Grains. ²Location: PL=Pore Lining, M=Matrix.

Hydric Soil Indicators:

- Histosol (A1)
- Histic Epipedon (A2)
- Black Histic (A3)
- Hydrogen Sulfide (A4)
- Stratified Layers (A5)
- Depleted Below Dark Surface (A11)
- Thick Dark Surface (A12)
- Sandy Mucky Mineral (S1)
- Sandy Gleyed Matrix (S4)
- Sandy Redox (S5)
- Stripped Matrix (S6)
- Dark Surface (S7)

- Polyvalue Below Surface (S8) (LRR R, MLRA 149B)
- Thin Dark Surface (S9) (LRR R, MLRA 149B)
- High Chroma Sands (S11) (LRR K, L)
- Loamy Mucky Mineral (F1) (LRR K, L)
- Loamy Gleyed Matrix (F2)
- Depleted Matrix (F3)
- Redox Dark Surface (F6)
- Depleted Dark Surface (F7)
- Redox Depressions (F8)
- Marl (F10) (LRR K, L)

Indicators for Problematic Hydric Soils³:

- 2 cm Muck (A10) (LRR K, L, MLRA 149B)
- Coast Prairie Redox (A16) (LRR K, L, R)
- 5 cm Mucky Peat or Peat (S3) (LRR K, L, R)
- Polyvalue Below Surface (S8) (LRR K, L)
- Thin Dark Surface (S9) (LRR K, L)
- Iron-Manganese Masses (F12) (LRR K, L, R)
- Piedmont Floodplain Soils (F19) (MLRA 149B)
- Mesic Spodic (TA6) (MLRA 144A, 145, 149B)
- Red Parent Material (F21)
- Very Shallow Dark Surface (TF12)
- Other (Explain in Remarks)

³Indicators of hydrophytic vegetation and wetland hydrology must be present, unless disturbed or problematic.

Restrictive Layer (if observed):

Type: Rock
 Depth (inches): 12

Hydric Soil Present? Yes X No

Remarks:

This data form is revised from Northcentral and Northeast Regional Supplement Version 2.0 to reflect the NRCS Field Indicators of Hydric Soils version 7.0 March 2013 Errata. (http://www.nrcs.usda.gov/Internet/FSE_DOCUMENTS/nrcs142p2_051293.docx)

WETLAND DETERMINATION DATA FORM – Northcentral and Northeast Region

Project/Site: New Bedford Industrial Park Infrastructure Installation City/County: New Bedford Sampling Date: 2/21/2022
 Applicant/Owner: Eversource Energy State: MA Sampling Point: 4
 Investigator(s): Sara Berryman, Olivia Footit Section, Township, Range: _____
 Landform (hillside, terrace, etc.): Hillside Local relief (concave, convex, none): Convex Slope (%): 3
 Subregion (LRR or MLRA): LRR R, MLRA 144A Lat: 41.718399 Long: -70.962601 Datum: WGS
 Soil Map Unit Name: Whitman fine sandy loam, 0 to 3 percent slopes, extremely stony NWI classification: PFO4

Are climatic / hydrologic conditions on the site typical for this time of year? Yes X No _____ (If no, explain in Remarks.)
 Are Vegetation _____, Soil _____, or Hydrology _____ significantly disturbed? Are "Normal Circumstances" present? Yes X No _____
 Are Vegetation _____, Soil _____, or Hydrology _____ naturally problematic? (If needed, explain any answers in Remarks.)

SUMMARY OF FINDINGS – Attach site map showing sampling point locations, transects, important features, etc.

Hydrophytic Vegetation Present?	Yes _____	No <u>X</u>	Is the Sampled Area within a Wetland? Yes <u>X</u> No _____ If yes, optional Wetland Site ID: <u>W03</u>
Hydric Soil Present?	Yes _____	No <u>X</u>	
Wetland Hydrology Present?	Yes <u>X</u>	No _____	
Remarks: (Explain alternative procedures here or in a separate report.)			

HYDROLOGY

Wetland Hydrology Indicators: <u>Primary Indicators (minimum of one is required; check all that apply)</u> _____ Surface Water (A1) _____ Water-Stained Leaves (B9) _____ High Water Table (A2) _____ Aquatic Fauna (B13) <u>X</u> Saturation (A3) _____ Marl Deposits (B15) _____ Water Marks (B1) _____ Hydrogen Sulfide Odor (C1) _____ Sediment Deposits (B2) _____ Oxidized Rhizospheres on Living Roots (C3) _____ Drift Deposits (B3) _____ Presence of Reduced Iron (C4) _____ Algal Mat or Crust (B4) _____ Recent Iron Reduction in Tilled Soils (C6) _____ Iron Deposits (B5) _____ Thin Muck Surface (C7) _____ Inundation Visible on Aerial Imagery (B7) _____ Other (Explain in Remarks) _____ Sparsely Vegetated Concave Surface (B8)	<u>Secondary Indicators (minimum of two required)</u> _____ Surface Soil Cracks (B6) _____ Drainage Patterns (B10) _____ Moss Trim Lines (B16) _____ Dry-Season Water Table (C2) _____ Crayfish Burrows (C8) _____ Saturation Visible on Aerial Imagery (C9) _____ Stunted or Stressed Plants (D1) _____ Geomorphic Position (D2) _____ Shallow Aquitard (D3) _____ Microtopographic Relief (D4) <u>X</u> FAC-Neutral Test (D5)
---	--

Field Observations: Surface Water Present? Yes _____ No <u>X</u> Depth (inches): _____ Water Table Present? Yes _____ No <u>X</u> Depth (inches): _____ Saturation Present? Yes <u>X</u> No _____ Depth (inches): <u>4</u> (includes capillary fringe)	Wetland Hydrology Present? Yes <u>X</u> No _____
---	---

Describe Recorded Data (stream gauge, monitoring well, aerial photos, previous inspections), if available:

Remarks:

VEGETATION – Use scientific names of plants.

Sampling Point: 4

Tree Stratum (Plot size: _____)	Absolute % Cover	Dominant Species?	Indicator Status
1. <u>Pinus strobus</u>	<u>10</u>	<u>Yes</u>	<u>FACU</u>
2. _____	_____	_____	_____
3. _____	_____	_____	_____
4. _____	_____	_____	_____
5. _____	_____	_____	_____
6. _____	_____	_____	_____
7. _____	_____	_____	_____
	<u>10</u> =Total Cover		
Sapling/Shrub Stratum (Plot size: _____)			
1. <u>Alnus incana</u>	<u>15</u>	<u>Yes</u>	<u>FACW</u>
2. _____	_____	_____	_____
3. _____	_____	_____	_____
4. _____	_____	_____	_____
5. _____	_____	_____	_____
6. _____	_____	_____	_____
7. _____	_____	_____	_____
	<u>15</u> =Total Cover		
Herb Stratum (Plot size: _____)			
1. <u>Onoclea sensibilis</u>	<u>15</u>	<u>Yes</u>	<u>FACW</u>
2. <u>Setaria pumila</u>	<u>2</u>	<u>No</u>	<u>FAC</u>
3. _____	_____	_____	_____
4. _____	_____	_____	_____
5. _____	_____	_____	_____
6. _____	_____	_____	_____
7. _____	_____	_____	_____
8. _____	_____	_____	_____
9. _____	_____	_____	_____
10. _____	_____	_____	_____
11. _____	_____	_____	_____
12. _____	_____	_____	_____
	<u>17</u> =Total Cover		
Woody Vine Stratum (Plot size: _____)			
1. <u>Smilax</u>	<u>20</u>	<u>Yes</u>	_____
2. _____	_____	_____	_____
3. _____	_____	_____	_____
4. _____	_____	_____	_____
	<u>20</u> =Total Cover		

Dominance Test worksheet:

Number of Dominant Species That Are OBL, FACW, or FAC: 2 (A)

Total Number of Dominant Species Across All Strata: 4 (B)

Percent of Dominant Species That Are OBL, FACW, or FAC: 50.0% (A/B)

Prevalence Index worksheet:

Total % Cover of:	Multiply by:
OBL species <u>0</u>	x 1 = <u>0</u>
FACW species <u>30</u>	x 2 = <u>60</u>
FAC species <u>2</u>	x 3 = <u>6</u>
FACU species <u>10</u>	x 4 = <u>40</u>
UPL species <u>0</u>	x 5 = <u>0</u>
Column Totals: <u>42</u> (A)	<u>106</u> (B)
Prevalence Index = B/A = <u>2.52</u>	

Hydrophytic Vegetation Indicators:

1 - Rapid Test for Hydrophytic Vegetation

2 - Dominance Test is >50%

3 - Prevalence Index is ≤3.0¹

4 - Morphological Adaptations¹ (Provide supporting data in Remarks or on a separate sheet)

 Problematic Hydrophytic Vegetation¹ (Explain)

¹Indicators of hydric soil and wetland hydrology must be present, unless disturbed or problematic.

Definitions of Vegetation Strata:

Tree – Woody plants 3 in. (7.6 cm) or more in diameter at breast height (DBH), regardless of height.

Sapling/shrub – Woody plants less than 3 in. DBH and greater than or equal to 3.28 ft (1 m) tall.

Herb – All herbaceous (non-woody) plants, regardless of size, and woody plants less than 3.28 ft tall.

Woody vines – All woody vines greater than 3.28 ft in height.

Hydrophytic Vegetation Present? Yes No X

Remarks: (Include photo numbers here or on a separate sheet.)

SOIL

Sampling Point: 4

Profile Description: (Describe to the depth needed to document the indicator or confirm the absence of indicators.)

Depth (inches)	Matrix		Redox Features				Texture	Remarks
	Color (moist)	%	Color (moist)	%	Type ¹	Loc ²		

¹Type: C=Concentration, D=Depletion, RM=Reduced Matrix, CS=Covered or Coated Sand Grains. ²Location: PL=Pore Lining, M=Matrix.

Hydric Soil Indicators:

- Histosol (A1)
- Histic Epipedon (A2)
- Black Histic (A3)
- Hydrogen Sulfide (A4)
- Stratified Layers (A5)
- Depleted Below Dark Surface (A11)
- Thick Dark Surface (A12)
- Sandy Mucky Mineral (S1)
- Sandy Gleyed Matrix (S4)
- Sandy Redox (S5)
- Stripped Matrix (S6)
- Dark Surface (S7)

- Polyvalue Below Surface (S8) (**LRR R, MLRA 149B**)
- Thin Dark Surface (S9) (**LRR R, MLRA 149B**)
- High Chroma Sands (S11) (**LRR K, L**)
- Loamy Mucky Mineral (F1) (**LRR K, L**)
- Loamy Gleyed Matrix (F2)
- Depleted Matrix (F3)
- Redox Dark Surface (F6)
- Depleted Dark Surface (F7)
- Redox Depressions (F8)
- Marl (F10) (**LRR K, L**)

Indicators for Problematic Hydric Soils³:

- 2 cm Muck (A10) (**LRR K, L, MLRA 149B**)
- Coast Prairie Redox (A16) (**LRR K, L, R**)
- 5 cm Mucky Peat or Peat (S3) (**LRR K, L, R**)
- Polyvalue Below Surface (S8) (**LRR K, L**)
- Thin Dark Surface (S9) (**LRR K, L**)
- Iron-Manganese Masses (F12) (**LRR K, L, R**)
- Piedmont Floodplain Soils (F19) (**MLRA 149B**)
- Mesic Spodic (TA6) (**MLRA 144A, 145, 149B**)
- Red Parent Material (F21)
- Very Shallow Dark Surface (TF12)
- Other (Explain in Remarks)

³Indicators of hydrophytic vegetation and wetland hydrology must be present, unless disturbed or problematic.

Restrictive Layer (if observed):

Type: _____
 Depth (inches): _____

Hydric Soil Present? Yes No

Remarks:
 This data form is revised from Northcentral and Northeast Regional Supplement Version 2.0 to reflect the NRCS Field Indicators of Hydric Soils version 7.0 March 2013 Errata. (http://www.nrcs.usda.gov/Internet/FSE_DOCUMENTS/nrcs142p2_051293.docx)

WETLAND DETERMINATION DATA FORM – Northcentral and Northeast Region

Project/Site: New Bedford Industrial Park Infrastructure Installation City/County: New Bedford Sampling Date: 2/21/2022
 Applicant/Owner: Eversource Energy State: MA Sampling Point: 5
 Investigator(s): Sara Berryman, Olivia Footit Section, Township, Range: _____
 Landform (hillside, terrace, etc.): Hillside Local relief (concave, convex, none): Convex Slope (%): 3
 Subregion (LRR or MLRA): LRR R, MLRA 144A Lat: 41.718374 Long: -70.962769 Datum: WGS
 Soil Map Unit Name: Whitman fine sandy loam, 0 to 3 percent slopes, extremely stony NWI classification: PFO4

Are climatic / hydrologic conditions on the site typical for this time of year? Yes No (If no, explain in Remarks.)
 Are Vegetation , Soil , or Hydrology significantly disturbed? Are "Normal Circumstances" present? Yes No
 Are Vegetation , Soil , or Hydrology naturally problematic? (If needed, explain any answers in Remarks.)

SUMMARY OF FINDINGS – Attach site map showing sampling point locations, transects, important features, etc.

Hydrophytic Vegetation Present?	Yes <input type="checkbox"/>	No <input checked="" type="checkbox"/>	Is the Sampled Area within a Wetland? Yes <input checked="" type="checkbox"/> No <input type="checkbox"/> If yes, optional Wetland Site ID: <u>W04</u>
Hydric Soil Present?	Yes <input type="checkbox"/>	No <input checked="" type="checkbox"/>	
Wetland Hydrology Present?	Yes <input checked="" type="checkbox"/>	No <input type="checkbox"/>	
Remarks: (Explain alternative procedures here or in a separate report.)			

HYDROLOGY

Wetland Hydrology Indicators: <u>Primary Indicators (minimum of one is required; check all that apply)</u> ___ Surface Water (A1) ___ Water-Stained Leaves (B9) ___ High Water Table (A2) ___ Aquatic Fauna (B13) <input checked="" type="checkbox"/> Saturation (A3) ___ Marl Deposits (B15) ___ Water Marks (B1) ___ Hydrogen Sulfide Odor (C1) ___ Sediment Deposits (B2) ___ Oxidized Rhizospheres on Living Roots (C3) ___ Drift Deposits (B3) ___ Presence of Reduced Iron (C4) ___ Algal Mat or Crust (B4) ___ Recent Iron Reduction in Tilled Soils (C6) ___ Iron Deposits (B5) ___ Thin Muck Surface (C7) ___ Inundation Visible on Aerial Imagery (B7) ___ Other (Explain in Remarks) ___ Sparsely Vegetated Concave Surface (B8)	<u>Secondary Indicators (minimum of two required)</u> ___ Surface Soil Cracks (B6) ___ Drainage Patterns (B10) ___ Moss Trim Lines (B16) ___ Dry-Season Water Table (C2) ___ Crayfish Burrows (C8) ___ Saturation Visible on Aerial Imagery (C9) ___ Stunted or Stressed Plants (D1) ___ Geomorphic Position (D2) ___ Shallow Aquitard (D3) ___ Microtopographic Relief (D4) <input checked="" type="checkbox"/> FAC-Neutral Test (D5)
--	---

Field Observations: Surface Water Present? Yes <input type="checkbox"/> No <input checked="" type="checkbox"/> Depth (inches): _____ Water Table Present? Yes <input type="checkbox"/> No <input checked="" type="checkbox"/> Depth (inches): _____ Saturation Present? Yes <input checked="" type="checkbox"/> No <input type="checkbox"/> Depth (inches): <u>4</u> (includes capillary fringe)	Wetland Hydrology Present? Yes <input checked="" type="checkbox"/> No <input type="checkbox"/>
---	---

Describe Recorded Data (stream gauge, monitoring well, aerial photos, previous inspections), if available:

Remarks:

VEGETATION – Use scientific names of plants.

Sampling Point: 5

Tree Stratum (Plot size: _____)	Absolute % Cover	Dominant Species?	Indicator Status
1. <u>Pinus strobus</u>	<u>10</u>	<u>Yes</u>	<u>FACU</u>
2. _____	_____	_____	_____
3. _____	_____	_____	_____
4. _____	_____	_____	_____
5. _____	_____	_____	_____
6. _____	_____	_____	_____
7. _____	_____	_____	_____
	<u>10</u> =Total Cover		
Sapling/Shrub Stratum (Plot size: _____)			
1. <u>Alnus incana</u>	<u>15</u>	<u>Yes</u>	<u>FACW</u>
2. _____	_____	_____	_____
3. _____	_____	_____	_____
4. _____	_____	_____	_____
5. _____	_____	_____	_____
6. _____	_____	_____	_____
7. _____	_____	_____	_____
	<u>15</u> =Total Cover		
Herb Stratum (Plot size: _____)			
1. <u>Onoclea sensibilis</u>	<u>15</u>	<u>Yes</u>	<u>FACW</u>
2. <u>Setaria pumila</u>	<u>2</u>	<u>No</u>	<u>FAC</u>
3. _____	_____	_____	_____
4. _____	_____	_____	_____
5. _____	_____	_____	_____
6. _____	_____	_____	_____
7. _____	_____	_____	_____
8. _____	_____	_____	_____
9. _____	_____	_____	_____
10. _____	_____	_____	_____
11. _____	_____	_____	_____
12. _____	_____	_____	_____
	<u>17</u> =Total Cover		
Woody Vine Stratum (Plot size: _____)			
1. <u>Smilax</u>	<u>20</u>	<u>Yes</u>	_____
2. _____	_____	_____	_____
3. _____	_____	_____	_____
4. _____	_____	_____	_____
	<u>20</u> =Total Cover		

Dominance Test worksheet:

Number of Dominant Species That Are OBL, FACW, or FAC: 2 (A)

Total Number of Dominant Species Across All Strata: 4 (B)

Percent of Dominant Species That Are OBL, FACW, or FAC: 50.0% (A/B)

Prevalence Index worksheet:

Total % Cover of:	Multiply by:
OBL species <u>0</u>	x 1 = <u>0</u>
FACW species <u>30</u>	x 2 = <u>60</u>
FAC species <u>2</u>	x 3 = <u>6</u>
FACU species <u>10</u>	x 4 = <u>40</u>
UPL species <u>0</u>	x 5 = <u>0</u>
Column Totals: <u>42</u> (A)	<u>106</u> (B)
Prevalence Index = B/A = <u>2.52</u>	

Hydrophytic Vegetation Indicators:

1 - Rapid Test for Hydrophytic Vegetation

2 - Dominance Test is >50%

3 - Prevalence Index is ≤3.0¹

4 - Morphological Adaptations¹ (Provide supporting data in Remarks or on a separate sheet)

 Problematic Hydrophytic Vegetation¹ (Explain)

¹Indicators of hydric soil and wetland hydrology must be present, unless disturbed or problematic.

Definitions of Vegetation Strata:

Tree – Woody plants 3 in. (7.6 cm) or more in diameter at breast height (DBH), regardless of height.

Sapling/shrub – Woody plants less than 3 in. DBH and greater than or equal to 3.28 ft (1 m) tall.

Herb – All herbaceous (non-woody) plants, regardless of size, and woody plants less than 3.28 ft tall.

Woody vines – All woody vines greater than 3.28 ft in height.

Hydrophytic Vegetation Present? Yes No X

Remarks: (Include photo numbers here or on a separate sheet.)

Profile Description: (Describe to the depth needed to document the indicator or confirm the absence of indicators.)

Depth (inches)	Matrix		Redox Features				Texture	Remarks
	Color (moist)	%	Color (moist)	%	Type ¹	Loc ²		

¹Type: C=Concentration, D=Depletion, RM=Reduced Matrix, CS=Covered or Coated Sand Grains. ²Location: PL=Pore Lining, M=Matrix.

Hydric Soil Indicators:			Indicators for Problematic Hydric Soils³:		
<input type="checkbox"/> Histosol (A1)	<input type="checkbox"/> Polyvalue Below Surface (S8) (LRR R, MLRA 149B)	<input type="checkbox"/> 2 cm Muck (A10) (LRR K, L, MLRA 149B)			
<input type="checkbox"/> Histic Epipedon (A2)	<input type="checkbox"/> Thin Dark Surface (S9) (LRR R, MLRA 149B)	<input type="checkbox"/> Coast Prairie Redox (A16) (LRR K, L, R)			
<input type="checkbox"/> Black Histic (A3)	<input type="checkbox"/> High Chroma Sands (S11) (LRR K, L)	<input type="checkbox"/> 5 cm Mucky Peat or Peat (S3) (LRR K, L, R)			
<input type="checkbox"/> Hydrogen Sulfide (A4)	<input type="checkbox"/> Loamy Mucky Mineral (F1) (LRR K, L)	<input type="checkbox"/> Polyvalue Below Surface (S8) (LRR K, L)			
<input type="checkbox"/> Stratified Layers (A5)	<input type="checkbox"/> Loamy Gleyed Matrix (F2)	<input type="checkbox"/> Thin Dark Surface (S9) (LRR K, L)			
<input type="checkbox"/> Depleted Below Dark Surface (A11)	<input type="checkbox"/> Depleted Matrix (F3)	<input type="checkbox"/> Iron-Manganese Masses (F12) (LRR K, L, R)			
<input type="checkbox"/> Thick Dark Surface (A12)	<input type="checkbox"/> Redox Dark Surface (F6)	<input type="checkbox"/> Piedmont Floodplain Soils (F19) (MLRA 149B)			
<input type="checkbox"/> Sandy Mucky Mineral (S1)	<input type="checkbox"/> Depleted Dark Surface (F7)	<input type="checkbox"/> Mesic Spodic (TA6) (MLRA 144A, 145, 149B)			
<input type="checkbox"/> Sandy Gleyed Matrix (S4)	<input type="checkbox"/> Redox Depressions (F8)	<input type="checkbox"/> Red Parent Material (F21)			
<input type="checkbox"/> Sandy Redox (S5)	<input type="checkbox"/> Marl (F10) (LRR K, L)	<input type="checkbox"/> Very Shallow Dark Surface (TF12)			
<input type="checkbox"/> Stripped Matrix (S6)		<input type="checkbox"/> Other (Explain in Remarks)			
<input type="checkbox"/> Dark Surface (S7)					

³Indicators of hydrophytic vegetation and wetland hydrology must be present, unless disturbed or problematic.

Restrictive Layer (if observed): Type: _____ Depth (inches): _____	Hydric Soil Present? Yes ___ No <u>X</u>
---	--

Remarks:
 This data form is revised from Northcentral and Northeast Regional Supplement Version 2.0 to reflect the NRCS Field Indicators of Hydric Soils version 7.0 March 2013 Errata. (http://www.nrcs.usda.gov/Internet/FSE_DOCUMENTS/nrcs142p2_051293.docx)

WETLAND DETERMINATION DATA FORM – Northcentral and Northeast Region

Project/Site: New Bedford Industrial Park Infrastructure Installation City/County: New Bedford Sampling Date: 2/21/2022
 Applicant/Owner: Eversource Energy State: MA Sampling Point: 6
 Investigator(s): Sara Berryman, Olivia Footit Section, Township, Range: _____
 Landform (hillside, terrace, etc.): Terrace Local relief (concave, convex, none): None Slope (%): 0
 Subregion (LRR or MLRA): LRR R, MLRA 144A Lat: 41.718281 Long: -70.963552 Datum: WGS
 Soil Map Unit Name: Whiteman fine sandy loam, 0 to 3 percent slopes, extremely stony NWI classification: PSS2

Are climatic / hydrologic conditions on the site typical for this time of year? Yes No _____ (If no, explain in Remarks.)
 Are Vegetation _____, Soil _____, or Hydrology _____ significantly disturbed? Are "Normal Circumstances" present? Yes No _____
 Are Vegetation _____, Soil _____, or Hydrology _____ naturally problematic? (If needed, explain any answers in Remarks.)

SUMMARY OF FINDINGS – Attach site map showing sampling point locations, transects, important features, etc.

Hydrophytic Vegetation Present? Yes <input checked="" type="checkbox"/> No _____ Hydric Soil Present? Yes <input checked="" type="checkbox"/> No _____ Wetland Hydrology Present? Yes <input checked="" type="checkbox"/> No _____	Is the Sampled Area within a Wetland? Yes <input checked="" type="checkbox"/> No _____ If yes, optional Wetland Site ID: <u>W05</u>
Remarks: (Explain alternative procedures here or in a separate report.) 	

HYDROLOGY

Wetland Hydrology Indicators: <u>Primary Indicators (minimum of one is required; check all that apply)</u> _____ Surface Water (A1) <input checked="" type="checkbox"/> Water-Stained Leaves (B9) <input checked="" type="checkbox"/> High Water Table (A2) _____ Aquatic Fauna (B13) <input checked="" type="checkbox"/> Saturation (A3) _____ Marl Deposits (B15) _____ Water Marks (B1) _____ Hydrogen Sulfide Odor (C1) _____ Sediment Deposits (B2) _____ Oxidized Rhizospheres on Living Roots (C3) _____ Drift Deposits (B3) _____ Presence of Reduced Iron (C4) _____ Algal Mat or Crust (B4) _____ Recent Iron Reduction in Tilled Soils (C6) _____ Iron Deposits (B5) _____ Thin Muck Surface (C7) _____ Inundation Visible on Aerial Imagery (B7) _____ Other (Explain in Remarks) _____ Sparsely Vegetated Concave Surface (B8)	<u>Secondary Indicators (minimum of two required)</u> _____ Surface Soil Cracks (B6) _____ Drainage Patterns (B10) _____ Moss Trim Lines (B16) _____ Dry-Season Water Table (C2) _____ Crayfish Burrows (C8) _____ Saturation Visible on Aerial Imagery (C9) _____ Stunted or Stressed Plants (D1) _____ Geomorphic Position (D2) _____ Shallow Aquitard (D3) _____ Microtopographic Relief (D4) <input checked="" type="checkbox"/> FAC-Neutral Test (D5)
---	---

Field Observations: Surface Water Present? Yes _____ No <input checked="" type="checkbox"/> Depth (inches): _____ Water Table Present? Yes <input checked="" type="checkbox"/> No _____ Depth (inches): <u>4</u> Saturation Present? Yes <input checked="" type="checkbox"/> No _____ Depth (inches): <u>0</u> (includes capillary fringe)	Wetland Hydrology Present? Yes <input checked="" type="checkbox"/> No _____
---	--

Describe Recorded Data (stream gauge, monitoring well, aerial photos, previous inspections), if available:

Remarks:

VEGETATION – Use scientific names of plants.

Sampling Point: 6

Tree Stratum (Plot size: _____)	Absolute % Cover	Dominant Species?	Indicator Status
1. <u>Pinus strobus</u>	10	Yes	FACU
2. _____	_____	_____	_____
3. _____	_____	_____	_____
4. _____	_____	_____	_____
5. _____	_____	_____	_____
6. _____	_____	_____	_____
7. _____	_____	_____	_____
	10 =Total Cover		
Sapling/Shrub Stratum (Plot size: _____)			
1. <u>Alnus incana</u>	15	Yes	FACW
2. _____	_____	_____	_____
3. _____	_____	_____	_____
4. _____	_____	_____	_____
5. _____	_____	_____	_____
6. _____	_____	_____	_____
7. _____	_____	_____	_____
	15 =Total Cover		
Herb Stratum (Plot size: _____)			
1. <u>Onoclea sensibilis</u>	15	Yes	FACW
2. <u>Setaria pumila</u>	2	No	FAC
3. _____	_____	_____	_____
4. _____	_____	_____	_____
5. _____	_____	_____	_____
6. _____	_____	_____	_____
7. _____	_____	_____	_____
8. _____	_____	_____	_____
9. _____	_____	_____	_____
10. _____	_____	_____	_____
11. _____	_____	_____	_____
12. _____	_____	_____	_____
	17 =Total Cover		
Woody Vine Stratum (Plot size: _____)			
1. <u>Smilax</u>	20	Yes	
2. _____	_____	_____	_____
3. _____	_____	_____	_____
4. _____	_____	_____	_____
	20 =Total Cover		

Dominance Test worksheet:

Number of Dominant Species That Are OBL, FACW, or FAC: 2 (A)

Total Number of Dominant Species Across All Strata: 4 (B)

Percent of Dominant Species That Are OBL, FACW, or FAC: 50.0% (A/B)

Prevalence Index worksheet:

Total % Cover of:	Multiply by:
OBL species <u>0</u>	x 1 = <u>0</u>
FACW species <u>30</u>	x 2 = <u>60</u>
FAC species <u>2</u>	x 3 = <u>6</u>
FACU species <u>10</u>	x 4 = <u>40</u>
UPL species <u>0</u>	x 5 = <u>0</u>
Column Totals: <u>42</u> (A)	<u>106</u> (B)
Prevalence Index = B/A = <u>2.52</u>	

- Hydrophytic Vegetation Indicators:**
- 1 - Rapid Test for Hydrophytic Vegetation
 - 2 - Dominance Test is >50%
 - 3 - Prevalence Index is ≤3.0¹
 - 4 - Morphological Adaptations¹ (Provide supporting data in Remarks or on a separate sheet)
 - Problematic Hydrophytic Vegetation¹ (Explain)
- ¹Indicators of hydric soil and wetland hydrology must be present, unless disturbed or problematic.

Definitions of Vegetation Strata:

Tree – Woody plants 3 in. (7.6 cm) or more in diameter at breast height (DBH), regardless of height.

Sapling/shrub – Woody plants less than 3 in. DBH and greater than or equal to 3.28 ft (1 m) tall.

Herb – All herbaceous (non-woody) plants, regardless of size, and woody plants less than 3.28 ft tall.

Woody vines – All woody vines greater than 3.28 ft in height.

Hydrophytic Vegetation Present? Yes X No

Remarks: (Include photo numbers here or on a separate sheet.)

Profile Description: (Describe to the depth needed to document the indicator or confirm the absence of indicators.)

Depth (inches)	Matrix		Redox Features				Texture	Remarks
	Color (moist)	%	Color (moist)	%	Type ¹	Loc ²		
0-6	10YR 2/1	100					Mucky Peat	
6-12	10YR 4/1	93	10YR 5/6	2	C	PL	Loamy/Clayey	
			10YR 2/2	5				
12-14	10YR 3/3	100					Loamy/Clayey	

¹Type: C=Concentration, D=Depletion, RM=Reduced Matrix, CS=Covered or Coated Sand Grains. ²Location: PL=Pore Lining, M=Matrix.

Hydric Soil Indicators:

- Histosol (A1)
- Histic Epipedon (A2)
- Black Histic (A3)
- Hydrogen Sulfide (A4)
- Stratified Layers (A5)
- Depleted Below Dark Surface (A11)
- Thick Dark Surface (A12)
- Sandy Mucky Mineral (S1)
- Sandy Gleyed Matrix (S4)
- Sandy Redox (S5)
- Stripped Matrix (S6)
- Dark Surface (S7)

- Polyvalue Below Surface (S8) (LRR R, MLRA 149B)
- Thin Dark Surface (S9) (LRR R, MLRA 149B)
- High Chroma Sands (S11) (LRR K, L)
- Loamy Mucky Mineral (F1) (LRR K, L)
- Loamy Gleyed Matrix (F2)
- Depleted Matrix (F3)
- Redox Dark Surface (F6)
- Depleted Dark Surface (F7)
- Redox Depressions (F8)
- Marl (F10) (LRR K, L)

Indicators for Problematic Hydric Soils³:

- 2 cm Muck (A10) (LRR K, L, MLRA 149B)
- Coast Prairie Redox (A16) (LRR K, L, R)
- 5 cm Mucky Peat or Peat (S3) (LRR K, L, R)
- Polyvalue Below Surface (S8) (LRR K, L)
- Thin Dark Surface (S9) (LRR K, L)
- Iron-Manganese Masses (F12) (LRR K, L, R)
- Piedmont Floodplain Soils (F19) (MLRA 149B)
- Mesic Spodic (TA6) (MLRA 144A, 145, 149B)
- Red Parent Material (F21)
- Very Shallow Dark Surface (TF12)
- Other (Explain in Remarks)

³Indicators of hydrophytic vegetation and wetland hydrology must be present, unless disturbed or problematic.

Restrictive Layer (if observed):

Type: Rock
 Depth (inches): 14

Hydric Soil Present? Yes No

Remarks:

This data form is revised from Northcentral and Northeast Regional Supplement Version 2.0 to reflect the NRCS Field Indicators of Hydric Soils version 7.0 March 2013 Errata. (http://www.nrcs.usda.gov/Internet/FSE_DOCUMENTS/nrcs142p2_051293.docx)

WETLAND DETERMINATION DATA FORM – Northcentral and Northeast Region

Project/Site: New Bedford Industrial Park Infrastructure Installation City/County: New Bedford Sampling Date: 3/1/2022
 Applicant/Owner: Eversource Energy State: MA Sampling Point: 7
 Investigator(s): Sara Berryman, Olivia Footit Section, Township, Range: _____
 Landform (hillside, terrace, etc.): Terrace Local relief (concave, convex, none): Concave Slope (%): 1
 Subregion (LRR or MLRA): LRR R, MLRA 144A Lat: 41.718348 Long: -70.959808 Datum: WGS
 Soil Map Unit Name: Sudbury fine sandy loam, 0 to 3 percent slopes NWI classification: PFO4

Are climatic / hydrologic conditions on the site typical for this time of year? Yes No _____ (If no, explain in Remarks.)
 Are Vegetation _____, Soil _____, or Hydrology _____ significantly disturbed? Are "Normal Circumstances" present? Yes No _____
 Are Vegetation _____, Soil _____, or Hydrology _____ naturally problematic? (If needed, explain any answers in Remarks.)

SUMMARY OF FINDINGS – Attach site map showing sampling point locations, transects, important features, etc.

Hydrophytic Vegetation Present? Yes <input checked="" type="checkbox"/> No _____ Hydric Soil Present? Yes <input checked="" type="checkbox"/> No _____ Wetland Hydrology Present? Yes <input checked="" type="checkbox"/> No _____	Is the Sampled Area within a Wetland? Yes <input checked="" type="checkbox"/> No _____ If yes, optional Wetland Site ID: <u>W06</u>
Remarks: (Explain alternative procedures here or in a separate report.) 	

HYDROLOGY

Wetland Hydrology Indicators: <u>Primary Indicators (minimum of one is required; check all that apply)</u> _____ Surface Water (A1) <input checked="" type="checkbox"/> Water-Stained Leaves (B9) <input checked="" type="checkbox"/> High Water Table (A2) _____ Aquatic Fauna (B13) <input checked="" type="checkbox"/> Saturation (A3) _____ Marl Deposits (B15) _____ Water Marks (B1) _____ Hydrogen Sulfide Odor (C1) _____ Sediment Deposits (B2) _____ Oxidized Rhizospheres on Living Roots (C3) _____ Drift Deposits (B3) _____ Presence of Reduced Iron (C4) _____ Algal Mat or Crust (B4) _____ Recent Iron Reduction in Tilled Soils (C6) _____ Iron Deposits (B5) _____ Thin Muck Surface (C7) _____ Inundation Visible on Aerial Imagery (B7) _____ Other (Explain in Remarks) _____ Sparsely Vegetated Concave Surface (B8)	<u>Secondary Indicators (minimum of two required)</u> _____ Surface Soil Cracks (B6) _____ Drainage Patterns (B10) _____ Moss Trim Lines (B16) _____ Dry-Season Water Table (C2) _____ Crayfish Burrows (C8) _____ Saturation Visible on Aerial Imagery (C9) _____ Stunted or Stressed Plants (D1) _____ Geomorphic Position (D2) _____ Shallow Aquitard (D3) _____ Microtopographic Relief (D4) <input checked="" type="checkbox"/> FAC-Neutral Test (D5)
---	---

Field Observations: Surface Water Present? Yes _____ No <input checked="" type="checkbox"/> Depth (inches): _____ Water Table Present? Yes <input checked="" type="checkbox"/> No _____ Depth (inches): <u>1</u> Saturation Present? Yes <input checked="" type="checkbox"/> No _____ Depth (inches): <u>4</u> (includes capillary fringe)	Wetland Hydrology Present? Yes <input checked="" type="checkbox"/> No _____
---	--

Describe Recorded Data (stream gauge, monitoring well, aerial photos, previous inspections), if available:

Remarks:

VEGETATION – Use scientific names of plants.

Sampling Point: 7

Tree Stratum (Plot size: _____)	Absolute % Cover	Dominant Species?	Indicator Status
1. <u>Acer rubrum</u>	<u>10</u>	<u>Yes</u>	<u>FAC</u>
2. _____	_____	_____	_____
3. _____	_____	_____	_____
4. _____	_____	_____	_____
5. _____	_____	_____	_____
6. _____	_____	_____	_____
7. _____	_____	_____	_____
		<u>10</u> =Total Cover	
Sapling/Shrub Stratum (Plot size: _____)			
1. <u>Spiraea tomentosa</u>	<u>20</u>	<u>Yes</u>	<u>FACW</u>
2. <u>Cornus alba</u>	<u>60</u>	<u>Yes</u>	<u>FACW</u>
3. _____	_____	_____	_____
4. _____	_____	_____	_____
5. _____	_____	_____	_____
6. _____	_____	_____	_____
7. _____	_____	_____	_____
		<u>80</u> =Total Cover	
Herb Stratum (Plot size: _____)			
1. <u>Andropogon glomeratus</u>	<u>20</u>	<u>Yes</u>	<u>FACW</u>
2. _____	_____	_____	_____
3. _____	_____	_____	_____
4. _____	_____	_____	_____
5. _____	_____	_____	_____
6. _____	_____	_____	_____
7. _____	_____	_____	_____
8. _____	_____	_____	_____
9. _____	_____	_____	_____
10. _____	_____	_____	_____
11. _____	_____	_____	_____
12. _____	_____	_____	_____
		<u>20</u> =Total Cover	
Woody Vine Stratum (Plot size: _____)			
1. _____	_____	_____	_____
2. _____	_____	_____	_____
3. _____	_____	_____	_____
4. _____	_____	_____	_____
		_____ =Total Cover	

Dominance Test worksheet:

Number of Dominant Species That Are OBL, FACW, or FAC: 4 (A)

Total Number of Dominant Species Across All Strata: 4 (B)

Percent of Dominant Species That Are OBL, FACW, or FAC: 100.0% (A/B)

Prevalence Index worksheet:

Total % Cover of:	Multiply by:
OBL species <u>0</u>	x 1 = <u>0</u>
FACW species <u>100</u>	x 2 = <u>200</u>
FAC species <u>10</u>	x 3 = <u>30</u>
FACU species <u>0</u>	x 4 = <u>0</u>
UPL species <u>0</u>	x 5 = <u>0</u>
Column Totals: <u>110</u> (A)	<u>230</u> (B)
Prevalence Index = B/A = <u>2.09</u>	

Hydrophytic Vegetation Indicators:

 1 - Rapid Test for Hydrophytic Vegetation

X 2 - Dominance Test is >50%

X 3 - Prevalence Index is ≤3.0¹

 4 - Morphological Adaptations¹ (Provide supporting data in Remarks or on a separate sheet)

 Problematic Hydrophytic Vegetation¹ (Explain)

¹Indicators of hydric soil and wetland hydrology must be present, unless disturbed or problematic.

Definitions of Vegetation Strata:

Tree – Woody plants 3 in. (7.6 cm) or more in diameter at breast height (DBH), regardless of height.

Sapling/shrub – Woody plants less than 3 in. DBH and greater than or equal to 3.28 ft (1 m) tall.

Herb – All herbaceous (non-woody) plants, regardless of size, and woody plants less than 3.28 ft tall.

Woody vines – All woody vines greater than 3.28 ft in height.

Hydrophytic Vegetation Present? Yes X No

Remarks: (Include photo numbers here or on a separate sheet.)

SOIL

Sampling Point: 7

Profile Description: (Describe to the depth needed to document the indicator or confirm the absence of indicators.)

Depth (inches)	Matrix		Redox Features				Texture	Remarks
	Color (moist)	%	Color (moist)	%	Type ¹	Loc ²		
0-2	10YR 2/2	100					Loamy/Clayey	
2-6	2.5YR 5/3	90	10YR 2/2	10			Loamy/Clayey	
6-10	2.5YR 4/3	100					Loamy/Clayey	
10-12	2.5YR 6/1	80	10Y 2.5/1	20				

¹Type: C=Concentration, D=Depletion, RM=Reduced Matrix, CS=Covered or Coated Sand Grains. ²Location: PL=Pore Lining, M=Matrix.

Hydric Soil Indicators:

- Histosol (A1)
- Histic Epipedon (A2)
- Black Histic (A3)
- Hydrogen Sulfide (A4)
- Stratified Layers (A5)
- Depleted Below Dark Surface (A11)
- Thick Dark Surface (A12)
- Sandy Mucky Mineral (S1)
- Sandy Gleyed Matrix (S4)
- Sandy Redox (S5)
- Stripped Matrix (S6)
- Dark Surface (S7)

- Polyvalue Below Surface (S8) (LRR R, MLRA 149B)
- Thin Dark Surface (S9) (LRR R, MLRA 149B)
- High Chroma Sands (S11) (LRR K, L)
- Loamy Mucky Mineral (F1) (LRR K, L)
- Loamy Gleyed Matrix (F2)
- Depleted Matrix (F3)
- Redox Dark Surface (F6)
- Depleted Dark Surface (F7)
- Redox Depressions (F8)
- Marl (F10) (LRR K, L)

Indicators for Problematic Hydric Soils³:

- 2 cm Muck (A10) (LRR K, L, MLRA 149B)
- Coast Prairie Redox (A16) (LRR K, L, R)
- 5 cm Mucky Peat or Peat (S3) (LRR K, L, R)
- Polyvalue Below Surface (S8) (LRR K, L)
- Thin Dark Surface (S9) (LRR K, L)
- Iron-Manganese Masses (F12) (LRR K, L, R)
- Piedmont Floodplain Soils (F19) (MLRA 149B)
- Mesic Spodic (TA6) (MLRA 144A, 145, 149B)
- Red Parent Material (F21)
- Very Shallow Dark Surface (TF12)
- Other (Explain in Remarks)

³Indicators of hydrophytic vegetation and wetland hydrology must be present, unless disturbed or problematic.

Restrictive Layer (if observed):

Type: Rock
 Depth (inches): 14

Hydric Soil Present? Yes X No

Remarks:
 This data form is revised from Northcentral and Northeast Regional Supplement Version 2.0 to reflect the NRCS Field Indicators of Hydric Soils version 7.0 March 2013 Errata. (http://www.nrcs.usda.gov/Internet/FSE_DOCUMENTS/nrcs142p2_051293.docx)

WETLAND DETERMINATION DATA FORM – Northcentral and Northeast Region

Project/Site: New Bedford Industrial Park Infrastructure Installation City/County: New Bedford Sampling Date: 3/1/2022
 Applicant/Owner: Eversource Energy State: MA Sampling Point: W07
 Investigator(s): Sara Berryman, Olivia Footit Section, Township, Range: _____
 Landform (hillside, terrace, etc.): Terrace Local relief (concave, convex, none): Concave Slope (%): 1
 Subregion (LRR or MLRA): LRR R, MLRA 144A Lat: 41.718128 Long: -70.961822 Datum: WGS
 Soil Map Unit Name: Swansea muck, 0 to 1 percent slopes NWI classification: PFO4

Are climatic / hydrologic conditions on the site typical for this time of year? Yes No _____ (If no, explain in Remarks.)
 Are Vegetation _____, Soil _____, or Hydrology _____ significantly disturbed? Are "Normal Circumstances" present? Yes No _____
 Are Vegetation _____, Soil _____, or Hydrology _____ naturally problematic? (If needed, explain any answers in Remarks.)

SUMMARY OF FINDINGS – Attach site map showing sampling point locations, transects, important features, etc.

Hydrophytic Vegetation Present? Yes <input checked="" type="checkbox"/> No _____ Hydric Soil Present? Yes <input checked="" type="checkbox"/> No _____ Wetland Hydrology Present? Yes <input checked="" type="checkbox"/> No _____	Is the Sampled Area within a Wetland? Yes <input checked="" type="checkbox"/> No _____ If yes, optional Wetland Site ID: <u>W07</u>
Remarks: (Explain alternative procedures here or in a separate report.) 	

HYDROLOGY

Wetland Hydrology Indicators: <u>Primary Indicators (minimum of one is required; check all that apply)</u> _____ Surface Water (A1) <input checked="" type="checkbox"/> Water-Stained Leaves (B9) <input checked="" type="checkbox"/> High Water Table (A2) _____ Aquatic Fauna (B13) <input checked="" type="checkbox"/> Saturation (A3) _____ Marl Deposits (B15) _____ Water Marks (B1) _____ Hydrogen Sulfide Odor (C1) _____ Sediment Deposits (B2) <input checked="" type="checkbox"/> Oxidized Rhizospheres on Living Roots (C3) _____ Drift Deposits (B3) _____ Presence of Reduced Iron (C4) _____ Algal Mat or Crust (B4) _____ Recent Iron Reduction in Tilled Soils (C6) _____ Iron Deposits (B5) _____ Thin Muck Surface (C7) _____ Inundation Visible on Aerial Imagery (B7) _____ Other (Explain in Remarks) _____ Sparsely Vegetated Concave Surface (B8)	<u>Secondary Indicators (minimum of two required)</u> _____ Surface Soil Cracks (B6) _____ Drainage Patterns (B10) _____ Moss Trim Lines (B16) _____ Dry-Season Water Table (C2) _____ Crayfish Burrows (C8) _____ Saturation Visible on Aerial Imagery (C9) _____ Stunted or Stressed Plants (D1) _____ Geomorphic Position (D2) _____ Shallow Aquitard (D3) _____ Microtopographic Relief (D4) <input checked="" type="checkbox"/> FAC-Neutral Test (D5)
---	---

Field Observations: Surface Water Present? Yes _____ No <input checked="" type="checkbox"/> Depth (inches): _____ Water Table Present? Yes <input checked="" type="checkbox"/> No _____ Depth (inches): <u>10</u> Saturation Present? Yes <input checked="" type="checkbox"/> No _____ Depth (inches): <u>0</u> (includes capillary fringe)	Wetland Hydrology Present? Yes <input checked="" type="checkbox"/> No _____
--	--

Describe Recorded Data (stream gauge, monitoring well, aerial photos, previous inspections), if available:

Remarks:

VEGETATION – Use scientific names of plants.

Sampling Point: W07

	Absolute % Cover	Dominant Species?	Indicator Status
Tree Stratum (Plot size: _____)			
1. <u><i>Acer rubrum</i></u>	<u>15</u>	<u>Yes</u>	<u>FAC</u>
2. <u><i>Ulmus americana</i></u>	<u>10</u>	<u>Yes</u>	<u>FACW</u>
3. _____	_____	_____	_____
4. _____	_____	_____	_____
5. _____	_____	_____	_____
6. _____	_____	_____	_____
7. _____	_____	_____	_____
	<u>25</u>	=Total Cover	
Sapling/Shrub Stratum (Plot size: _____)			
1. <u><i>Rosa multiflora</i></u>	<u>10</u>	<u>Yes</u>	<u>FACU</u>
2. <u><i>Spiraea tomentosa</i></u>	<u>5</u>	<u>Yes</u>	<u>FACW</u>
3. _____	_____	_____	_____
4. _____	_____	_____	_____
5. _____	_____	_____	_____
6. _____	_____	_____	_____
7. _____	_____	_____	_____
	<u>15</u>	=Total Cover	
Herb Stratum (Plot size: _____)			
1. <u><i>Phragmites australis</i></u>	<u>80</u>	<u>Yes</u>	<u>FACW</u>
2. _____	_____	_____	_____
3. _____	_____	_____	_____
4. _____	_____	_____	_____
5. _____	_____	_____	_____
6. _____	_____	_____	_____
7. _____	_____	_____	_____
8. _____	_____	_____	_____
9. _____	_____	_____	_____
10. _____	_____	_____	_____
11. _____	_____	_____	_____
12. _____	_____	_____	_____
	<u>80</u>	=Total Cover	
Woody Vine Stratum (Plot size: _____)			
1. _____	_____	_____	_____
2. _____	_____	_____	_____
3. _____	_____	_____	_____
4. _____	_____	_____	_____
	_____	=Total Cover	

Dominance Test worksheet:

Number of Dominant Species That Are OBL, FACW, or FAC: 4 (A)

Total Number of Dominant Species Across All Strata: 5 (B)

Percent of Dominant Species That Are OBL, FACW, or FAC: 80.0% (A/B)

Prevalence Index worksheet:

Total % Cover of:	Multiply by:
OBL species <u>0</u>	x 1 = <u>0</u>
FACW species <u>95</u>	x 2 = <u>190</u>
FAC species <u>15</u>	x 3 = <u>45</u>
FACU species <u>10</u>	x 4 = <u>40</u>
UPL species <u>0</u>	x 5 = <u>0</u>
Column Totals: <u>120</u> (A)	<u>275</u> (B)
Prevalence Index = B/A = <u>2.29</u>	

- Hydrophytic Vegetation Indicators:**
- 1 - Rapid Test for Hydrophytic Vegetation
 - 2 - Dominance Test is >50%
 - 3 - Prevalence Index is ≤3.0¹
 - 4 - Morphological Adaptations¹ (Provide supporting data in Remarks or on a separate sheet)
 - Problematic Hydrophytic Vegetation¹ (Explain)
- ¹Indicators of hydric soil and wetland hydrology must be present, unless disturbed or problematic.

Definitions of Vegetation Strata:

Tree – Woody plants 3 in. (7.6 cm) or more in diameter at breast height (DBH), regardless of height.

Sapling/shrub – Woody plants less than 3 in. DBH and greater than or equal to 3.28 ft (1 m) tall.

Herb – All herbaceous (non-woody) plants, regardless of size, and woody plants less than 3.28 ft tall.

Woody vines – All woody vines greater than 3.28 ft in height.

Hydrophytic Vegetation Present? Yes No

Remarks: (Include photo numbers here or on a separate sheet.)

SOIL

Sampling Point: W07

Profile Description: (Describe to the depth needed to document the indicator or confirm the absence of indicators.)								
Depth (inches)	Matrix		Redox Features				Texture	Remarks
	Color (moist)	%	Color (moist)	%	Type ¹	Loc ²		
0-1	10YR 2/1	100					Mucky Peat	
1-7	10YR 3/2	80	10YR 5/1	10	D	M	Loamy/Clayey	
			10YR 2/1	10		M		
7-10	10YR 4/2	100					Sandy	
10-15	10YR 2/1	50	10YR 2/2	50			Loamy/Clayey	Oxidized Rhysopheres

¹Type: C=Concentration, D=Depletion, RM=Reduced Matrix, CS=Covered or Coated Sand Grains. ²Location: PL=Pore Lining, M=Matrix.

Hydric Soil Indicators:

- Histosol (A1)
- Histic Epipedon (A2)
- Black Histic (A3)
- Hydrogen Sulfide (A4)
- Stratified Layers (A5)
- Depleted Below Dark Surface (A11)
- Thick Dark Surface (A12)
- Sandy Mucky Mineral (S1)
- Sandy Gleyed Matrix (S4)
- Sandy Redox (S5)
- Stripped Matrix (S6)
- Dark Surface (S7)

- Polyvalue Below Surface (S8) (LRR R, MLRA 149B)
- Thin Dark Surface (S9) (LRR R, MLRA 149B)
- High Chroma Sands (S11) (LRR K, L)
- Loamy Mucky Mineral (F1) (LRR K, L)
- Loamy Gleyed Matrix (F2)
- Depleted Matrix (F3)
- Redox Dark Surface (F6)
- Depleted Dark Surface (F7)
- Redox Depressions (F8)
- Marl (F10) (LRR K, L)

Indicators for Problematic Hydric Soils³:

- 2 cm Muck (A10) (LRR K, L, MLRA 149B)
- Coast Prairie Redox (A16) (LRR K, L, R)
- 5 cm Mucky Peat or Peat (S3) (LRR K, L, R)
- Polyvalue Below Surface (S8) (LRR K, L)
- Thin Dark Surface (S9) (LRR K, L)
- Iron-Manganese Masses (F12) (LRR K, L, R)
- Piedmont Floodplain Soils (F19) (MLRA 149B)
- Mesic Spodic (TA6) (MLRA 144A, 145, 149B)
- Red Parent Material (F21)
- Very Shallow Dark Surface (TF12)
- Other (Explain in Remarks)

³Indicators of hydrophytic vegetation and wetland hydrology must be present, unless disturbed or problematic.

Restrictive Layer (if observed):

Type: Rock
 Depth (inches): 15

Hydric Soil Present? Yes X No

Remarks:

This data form is revised from Northcentral and Northeast Regional Supplement Version 2.0 to reflect the NRCS Field Indicators of Hydric Soils version 7.0 March 2013 Errata. (http://www.nrcs.usda.gov/Internet/FSE_DOCUMENTS/nrcs142p2_051293.docx)

WETLAND DETERMINATION DATA FORM – Northcentral and Northeast Region

Project/Site: New Bedford Industrial Park Infrastructure Installation City/County: New Bedford Sampling Date: 3/1/2022
 Applicant/Owner: Eversource Energy State: MA Sampling Point: 9
 Investigator(s): Sara Berryman, Olivia Footit Section, Township, Range: _____
 Landform (hillside, terrace, etc.): Terrace Local relief (concave, convex, none): Concave Slope (%): 1
 Subregion (LRR or MLRA): LRR R, MLRA 144A Lat: 41.718135 Long: -70.963118 Datum: WGS
 Soil Map Unit Name: Whitman fine sandy loam, 0 to 3 percent slopes, extremely stony NWI classification: PFO4

Are climatic / hydrologic conditions on the site typical for this time of year? Yes No (If no, explain in Remarks.)
 Are Vegetation , Soil , or Hydrology significantly disturbed? Are "Normal Circumstances" present? Yes No
 Are Vegetation , Soil , or Hydrology naturally problematic? (If needed, explain any answers in Remarks.)

SUMMARY OF FINDINGS – Attach site map showing sampling point locations, transects, important features, etc.

Hydrophytic Vegetation Present? Yes <input checked="" type="checkbox"/> No <input type="checkbox"/> Hydric Soil Present? Yes <input checked="" type="checkbox"/> No <input type="checkbox"/> Wetland Hydrology Present? Yes <input checked="" type="checkbox"/> No <input type="checkbox"/>	Is the Sampled Area within a Wetland? Yes <input checked="" type="checkbox"/> No <input type="checkbox"/> If yes, optional Wetland Site ID: <u>W08</u>
Remarks: (Explain alternative procedures here or in a separate report.) 	

HYDROLOGY

Wetland Hydrology Indicators: <u>Primary Indicators (minimum of one is required; check all that apply)</u> <input type="checkbox"/> Surface Water (A1) <input checked="" type="checkbox"/> Water-Stained Leaves (B9) <input checked="" type="checkbox"/> High Water Table (A2) <input type="checkbox"/> Aquatic Fauna (B13) <input checked="" type="checkbox"/> Saturation (A3) <input type="checkbox"/> Marl Deposits (B15) <input type="checkbox"/> Water Marks (B1) <input type="checkbox"/> Hydrogen Sulfide Odor (C1) <input type="checkbox"/> Sediment Deposits (B2) <input type="checkbox"/> Oxidized Rhizospheres on Living Roots (C3) <input type="checkbox"/> Drift Deposits (B3) <input type="checkbox"/> Presence of Reduced Iron (C4) <input type="checkbox"/> Algal Mat or Crust (B4) <input type="checkbox"/> Recent Iron Reduction in Tilled Soils (C6) <input type="checkbox"/> Iron Deposits (B5) <input type="checkbox"/> Thin Muck Surface (C7) <input type="checkbox"/> Inundation Visible on Aerial Imagery (B7) <input type="checkbox"/> Other (Explain in Remarks) <input type="checkbox"/> Sparsely Vegetated Concave Surface (B8)	<u>Secondary Indicators (minimum of two required)</u> <input type="checkbox"/> Surface Soil Cracks (B6) <input type="checkbox"/> Drainage Patterns (B10) <input type="checkbox"/> Moss Trim Lines (B16) <input type="checkbox"/> Dry-Season Water Table (C2) <input type="checkbox"/> Crayfish Burrows (C8) <input type="checkbox"/> Saturation Visible on Aerial Imagery (C9) <input type="checkbox"/> Stunted or Stressed Plants (D1) <input type="checkbox"/> Geomorphic Position (D2) <input type="checkbox"/> Shallow Aquitard (D3) <input type="checkbox"/> Microtopographic Relief (D4) <input checked="" type="checkbox"/> FAC-Neutral Test (D5)
---	---

Field Observations: Surface Water Present? Yes <input type="checkbox"/> No <input checked="" type="checkbox"/> Depth (inches): _____ Water Table Present? Yes <input checked="" type="checkbox"/> No <input type="checkbox"/> Depth (inches): <u>4</u> Saturation Present? Yes <input checked="" type="checkbox"/> No <input type="checkbox"/> Depth (inches): <u>4</u> (includes capillary fringe)	Wetland Hydrology Present? Yes <input checked="" type="checkbox"/> No <input type="checkbox"/>
--	---

Describe Recorded Data (stream gauge, monitoring well, aerial photos, previous inspections), if available:

Remarks:

VEGETATION – Use scientific names of plants.

Sampling Point: 9

Tree Stratum (Plot size: _____)	Absolute % Cover	Dominant Species?	Indicator Status
1. <u>Acer rubrum</u>	10	Yes	FAC
2. _____	_____	_____	_____
3. _____	_____	_____	_____
4. _____	_____	_____	_____
5. _____	_____	_____	_____
6. _____	_____	_____	_____
7. _____	_____	_____	_____
	10 =Total Cover		
Sapling/Shrub Stratum (Plot size: _____)			
1. <u>Cornus alba</u>	40	Yes	FACW
2. <u>Spiraea tomentosa</u>	10	No	FACW
3. <u>Rosa multiflora</u>	10	No	FACU
4. <u>Solidago altissima</u>	10	No	FACU
5. _____	_____	_____	_____
6. _____	_____	_____	_____
7. _____	_____	_____	_____
	70 =Total Cover		
Herb Stratum (Plot size: _____)			
1. _____	_____	_____	_____
2. _____	_____	_____	_____
3. _____	_____	_____	_____
4. _____	_____	_____	_____
5. _____	_____	_____	_____
6. _____	_____	_____	_____
7. _____	_____	_____	_____
8. _____	_____	_____	_____
9. _____	_____	_____	_____
10. _____	_____	_____	_____
11. _____	_____	_____	_____
12. _____	_____	_____	_____
	_____ =Total Cover		
Woody Vine Stratum (Plot size: _____)			
1. <u>smilax</u>	10	Yes	
2. _____	_____	_____	_____
3. _____	_____	_____	_____
4. _____	_____	_____	_____
	10 =Total Cover		

Dominance Test worksheet:

Number of Dominant Species That Are OBL, FACW, or FAC: 2 (A)

Total Number of Dominant Species Across All Strata: 3 (B)

Percent of Dominant Species That Are OBL, FACW, or FAC: 66.7% (A/B)

Prevalence Index worksheet:

Total % Cover of:	Multiply by:
OBL species <u>0</u>	x 1 = <u>0</u>
FACW species <u>50</u>	x 2 = <u>100</u>
FAC species <u>10</u>	x 3 = <u>30</u>
FACU species <u>20</u>	x 4 = <u>80</u>
UPL species <u>0</u>	x 5 = <u>0</u>
Column Totals: <u>80</u> (A)	<u>210</u> (B)
Prevalence Index = B/A = <u>2.63</u>	

- Hydrophytic Vegetation Indicators:**
- 1 - Rapid Test for Hydrophytic Vegetation
 - 2 - Dominance Test is >50%
 - 3 - Prevalence Index is ≤3.0¹
 - 4 - Morphological Adaptations¹ (Provide supporting data in Remarks or on a separate sheet)
 - Problematic Hydrophytic Vegetation¹ (Explain)
- ¹Indicators of hydric soil and wetland hydrology must be present, unless disturbed or problematic.

Definitions of Vegetation Strata:

Tree – Woody plants 3 in. (7.6 cm) or more in diameter at breast height (DBH), regardless of height.

Sapling/shrub – Woody plants less than 3 in. DBH and greater than or equal to 3.28 ft (1 m) tall.

Herb – All herbaceous (non-woody) plants, regardless of size, and woody plants less than 3.28 ft tall.

Woody vines – All woody vines greater than 3.28 ft in height.

Hydrophytic Vegetation Present? Yes No

Remarks: (Include photo numbers here or on a separate sheet.)

Profile Description: (Describe to the depth needed to document the indicator or confirm the absence of indicators.)

Depth (inches)	Matrix		Redox Features				Texture	Remarks
	Color (moist)	%	Color (moist)	%	Type ¹	Loc ²		
0-4	10YR 2/2	85	7.5YR 4/6	15	C	PL	Loamy/Clayey	Prominent redox concentrations
4-9	10YR 2/1	100					Muck	
9-12	10YR 5/2	100					Sandy	

¹Type: C=Concentration, D=Depletion, RM=Reduced Matrix, CS=Covered or Coated Sand Grains. ²Location: PL=Pore Lining, M=Matrix.

Hydric Soil Indicators:

- Histosol (A1)
- Histic Epipedon (A2)
- Black Histic (A3)
- Hydrogen Sulfide (A4)
- Stratified Layers (A5)
- Depleted Below Dark Surface (A11)
- Thick Dark Surface (A12)
- Sandy Mucky Mineral (S1)
- Sandy Gleyed Matrix (S4)
- Sandy Redox (S5)
- Stripped Matrix (S6)
- Dark Surface (S7)

- Polyvalue Below Surface (S8) (LRR R, MLRA 149B)
- Thin Dark Surface (S9) (LRR R, MLRA 149B)
- High Chroma Sands (S11) (LRR K, L)
- Loamy Mucky Mineral (F1) (LRR K, L)
- Loamy Gleyed Matrix (F2)
- Depleted Matrix (F3)
- Redox Dark Surface (F6)
- Depleted Dark Surface (F7)
- Redox Depressions (F8)
- Marl (F10) (LRR K, L)

Indicators for Problematic Hydric Soils³:

- 2 cm Muck (A10) (LRR K, L, MLRA 149B)
- Coast Prairie Redox (A16) (LRR K, L, R)
- 5 cm Mucky Peat or Peat (S3) (LRR K, L, R)
- Polyvalue Below Surface (S8) (LRR K, L)
- Thin Dark Surface (S9) (LRR K, L)
- Iron-Manganese Masses (F12) (LRR K, L, R)
- Piedmont Floodplain Soils (F19) (MLRA 149B)
- Mesic Spodic (TA6) (MLRA 144A, 145, 149B)
- Red Parent Material (F21)
- Very Shallow Dark Surface (TF12)
- Other (Explain in Remarks)

³Indicators of hydrophytic vegetation and wetland hydrology must be present, unless disturbed or problematic.

Restrictive Layer (if observed):

Type: Rock
 Depth (inches): 12

Hydric Soil Present? Yes X No

Remarks:

This data form is revised from Northcentral and Northeast Regional Supplement Version 2.0 to reflect the NRCS Field Indicators of Hydric Soils version 7.0 March 2013 Errata. (http://www.nrcs.usda.gov/Internet/FSE_DOCUMENTS/nrcs142p2_051293.docx)

APPENDIX B

PHOTOGRAPHS

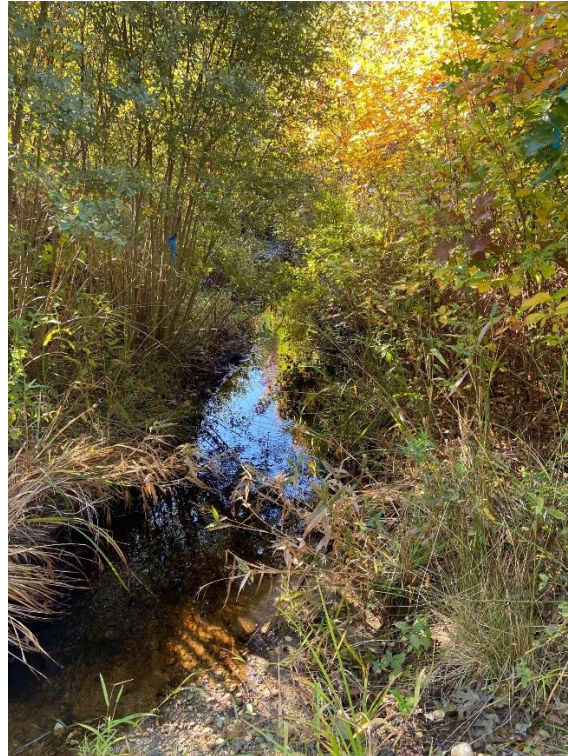

Downstream view of stream 1



Upstream view of stream 1

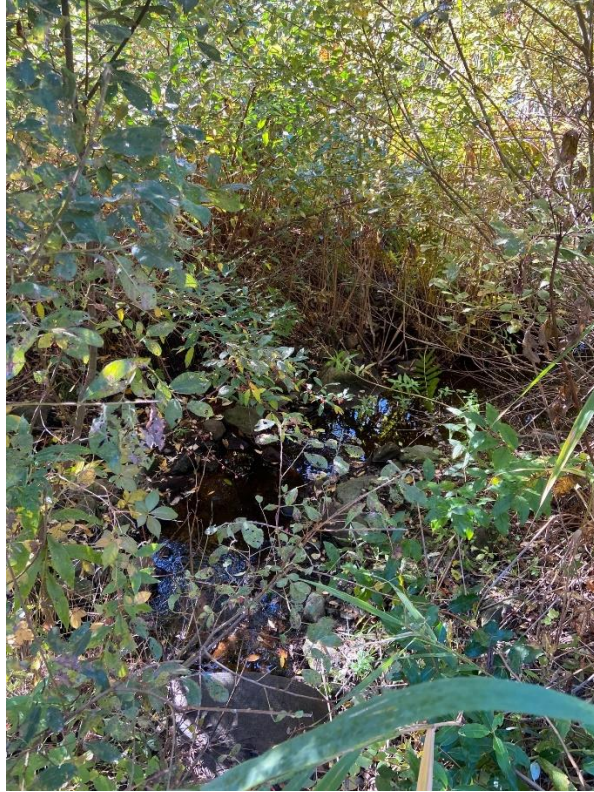

Downstream view of stream 2

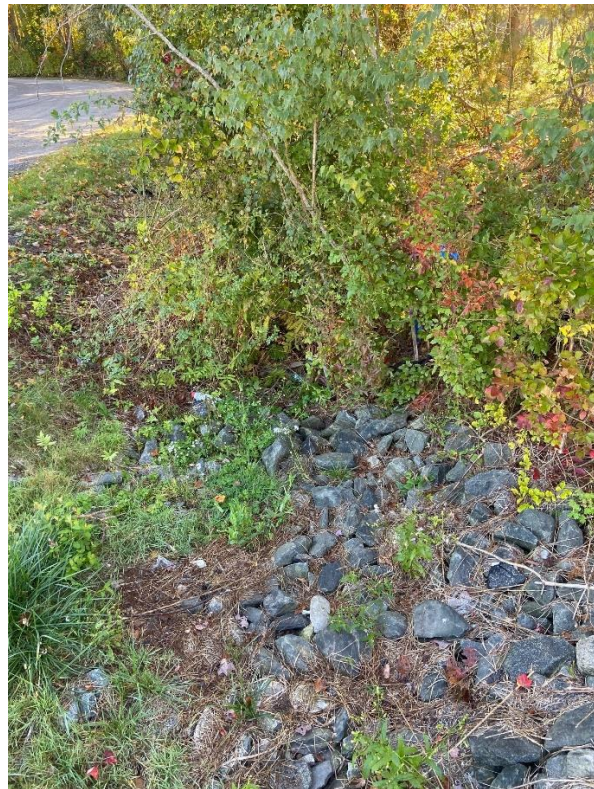

Downstream view of intermittent stream 2



Upstream view of stream 2



View of Wetland 1



View of Wetland 2



View of Wetland 3

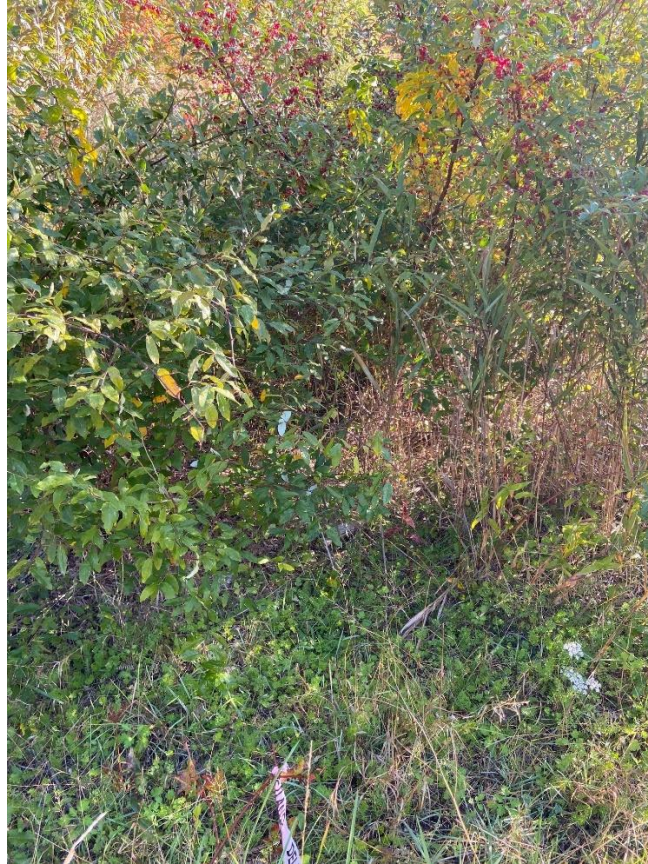

View of Wetland 4



View of Wetland 5



View of Wetland 6



View of Wetland 7



View of Wetland 8



ATTACHMENT D
Abutter Notification

**NOTIFICATION TO ABUTTERS UNDER THE CITY OF NEW BEDFORD WETLANDS
ORDINANCE AND THE MA WETLANDS PROTECTION ACT**

In accordance with the City of New Bedford Wetlands Ordinance (New Bedford Code of Ordinances Sections 15-101 through 15-112) and the MA Wetlands Protection Act (M.G.L. c. 131 S.40) you are hereby notified of the following:

The name of the applicant Eversource

The applicant has filed a Notice of Intent for the municipality of New Bedford, Massachusetts seeking permission to remove, fill, dredge or alter an area subject to protection under the City of New Bedford Wetlands Ordinance and MA Wetlands Protection Act.

The address of the lot where the activity is proposed is: Flaherty Drive
Assessors Map 133 ; Lot 62, 12, 10, 54, 66

Copies of the Notice of Intent may be examined at the New Bedford Conservation Commission, Room 304 – City Hall, 133 William St. New Bedford, MA 02740 between the hours of 8:00 AM and 4:00 PM, Monday through Friday. For more information contact the New Bedford Conservation Commission at 508-991-6188.

Copies of the Notice of Intent may be obtained from either (check one) the applicant _____ or the applicant's representative X by calling this telephone number 508-270-6505 between the hours of 8:00 AM and 4:00 PM Monday through Friday.

Information regarding the date, time and place of the Public Hearing may be obtained from the New Bedford Conservation Commission by calling 508-991-6188 between the hours of 8:00 AM and 4:00 PM Monday through Friday.

Note: Notice of the Public Hearing, including its date, time and place will be posted in the City Hall not less than forty eight (48) hours in advance of the meeting.

Note: Notice of the Public Hearing including its date, time and place will be published at least five (5) days in advance of the Public Hearing in the Standard Times newspaper.

Note: You may also contact the New Bedford Conservation Commission at 508-991-6188 for more information about this publication, the City of New Bedford Wetlands Ordinance or the MA Wetlands Protection Act.



City of New Bedford
REQUEST for a CERTIFIED ABUTTERS LIST

This information is needed so that an official abutters list as required by MA General Law may be created and used in notifying abutters. You, as applicant, are responsible for picking up and paying for the certified abutters list from the assessor's office (city hall, room #109).

SUBJECT PROPERTY			
MAP #	133	LOT(S)#	54, 66
ADDRESS: John Vertente Boulevard			
OWNER INFORMATION			
NAME: Acushnet Company, Consolidated Edison			
MAILING ADDRESS: PO Box 965, Fairhaven, MA 02719 100 Summit Lake Drive, Valhalla, NY 10595			
APPLICANT/CONTACT PERSON INFORMATION			
NAME (IF DIFFERENT): Eileen Piskura			
MAILING ADDRESS (IF DIFFERENT): 4 Technology Drive Suite 110 Westborough, MA 0158			
TELEPHONE #	508-270-6505		
EMAIL ADDRESS:	episkura@kleinfelder.com		
REASON FOR THIS REQUEST: <i>Check appropriate</i>			
<input type="checkbox"/>	ZONING BOARD OF APPEALS APPLICATION		
<input type="checkbox"/>	PLANNING BOARD APPLICATION		
<input checked="" type="checkbox"/>	CONSERVATION COMMISSION APPLICATION		
<input type="checkbox"/>	LICENSING BOARD APPLICATION		
<input type="checkbox"/>	OTHER (<i>Please explain</i>):		

Once obtained, the Certified List of Abutters must be attached to this Certification Letter.
Submit this form to the Department of City Planning, Room 303 in City Hall, 133 William Street, or Email to Angela.Goncalves@newbedford-ma.gov. The applicant is responsible for picking up and paying for the certified abutters list from the Assessor's Office (city hall, room #109).

Official Use Only:

As Assistant City Assessor to the City of New Bedford's Board of Assessors, I do hereby certify that the names and addresses as identified on the attached "abutters list" are duly recorded and appear on the most recent tax.

Judith M. Serdahl

Printed Name

Judith M. Serdahl

Signature

9/19/2022

Date

Amount Due

\$5.00

Date Paid

9/16/2022

Confirmation Number

Check-1403

CITY OF NEW BEDFORD

Schedule of Departmental Payments to Treasurer
Single Charge Code

Department/Contact: ASSESSORS
GL String: 01411160-439020
Treasury: TW05-101009

Date: Paid - 9/16/22
9/15/2022
Charge Code: ASSFEE

From Whom	Source (cash, check, etc)	Amount	Total
DEPARTMENTAL RECEIPT	CC	\$ 5.00	
ABUTTERS LIST	Check - 1403		
133-54,66			
John Vertente Boulevard			
Eileen Piskura			

To the City Treasurer:

The above is a detailed list of revenue collected by me, amounting in the aggregate of

_____ Dollars

Receipt# 4077699

Signature: 
Title: PRINCIPAL CLERK

CITY OF NEW BEDFORD

Schedule of Departmental Payments to Treasurer
Single Charge Code

Department/Contact: ASSESSORS
GL String: 01411160-439020
Treasury: TW05-101009

Date: 9/15/2022
Charge Code: ASSFEE

From Whom	Source (cash, check, etc)	Amount	Total
DEPARTMENTAL RECEIPT	CC	\$ 5.00	
ABUTTERS LIST	CHECK-1403		
133-54,66			
John Vertente Boulevard			
Eileen Piskura			

To the Departmental Officer making the Payment

Received in Treasurer's Office _____, the sum of
_____ Dollars

for collections, as per schedule of this date, filed in my office

Receipt# 4077699

City Treasurer
By _____

September 15, 2022
Dear Applicant,

Please find below the List of Abutters within 100 feet of the property known as John Vertente Blvd (Map: 133, Lot: 54,66). The current ownership listed herein must be checked and verified by the City of New Bedford Assessor's Office. Following said verification, the list shall be considered a Certified List of Abutters.

Please note that multiple listed properties with identical owner name and mailing address shall be considered duplicates and shall require only 1 mailing. Additionally, City of New Bedford-Owned properties shall not require mailed notice.

<u>Parcel</u>	<u>Location</u>	<u>Owner and Mailing Address</u>
133-66	SS JOHN VERTENTE BLVD	CONSOLIDATED EDISON DEVELOPMENT INC, 100 SUMMIT LAKE DRIVE - SUITE 410 VALHALLA, NY 10595-1373
133-7	960 FLAHERTY DR	AFC CABLE SYSTEMS INC, 260 DUCHAINE BOULEVARD NEW BEDFORD, MA 02745
133-54	SS JOHN VERTENTE BLVD	ACUSHNET COMPANY, C/O SUE BRENNER P O BOX 965 FAIRHAVEN, MA 02719-0965
133-55	214 SAMUEL BARNETT BLVD	EASTERN FISHERIES INC, 14 HERVEY TICHON AVENUE NEW BEDFORD, MA 02740

Note: This map was developed using the best available data and serves as a guide rather than a determination. Data should be confirmed in the field to ensure accuracy.

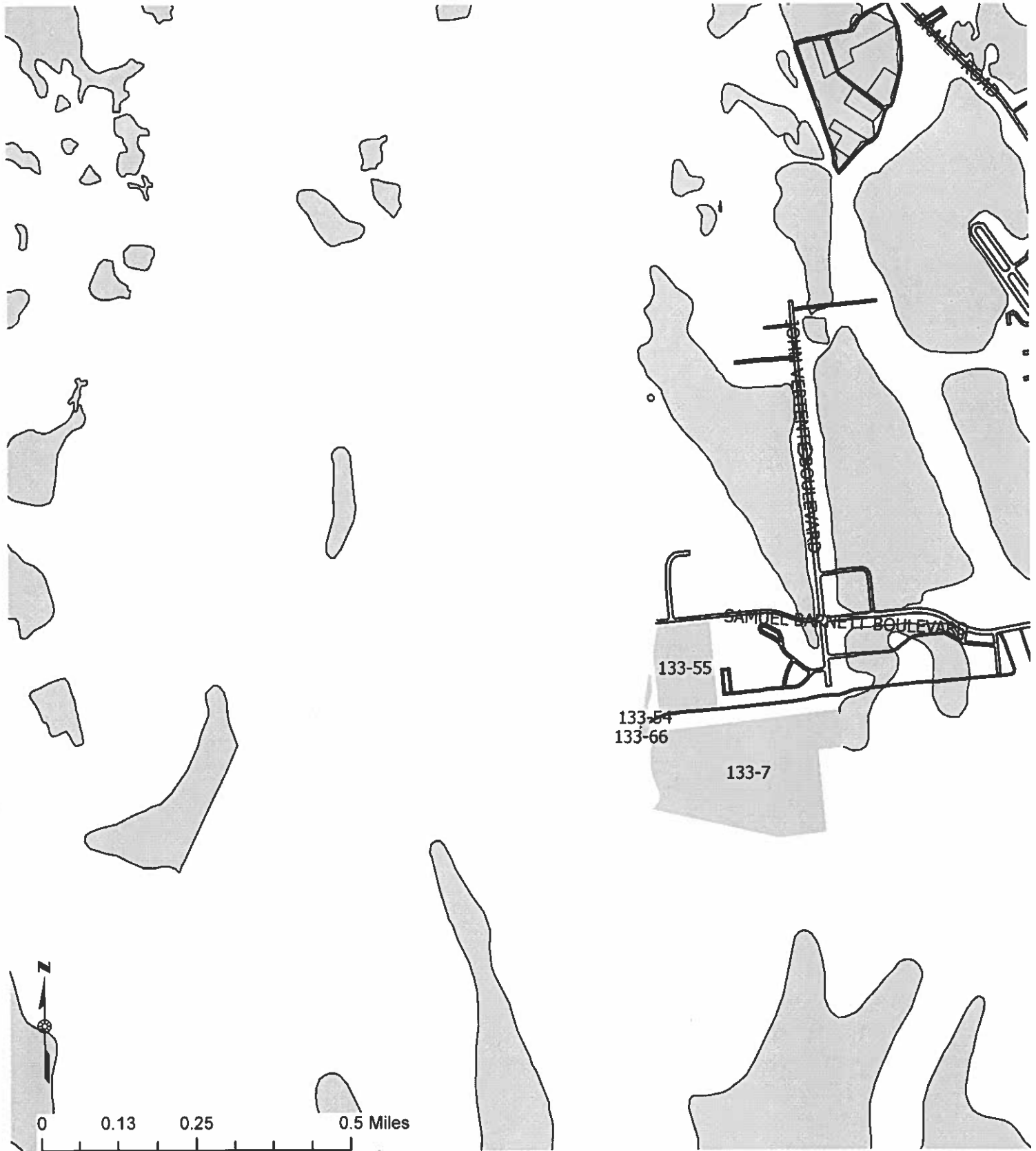

City of New Bedford, Massachusetts
Department of City Planning

Parcels within 100FT

- Road Edge
- Water
- Street Names
- 133-54,66

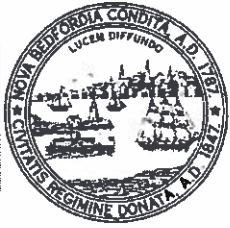

City of New Bedford
REQUEST for a CERTIFIED ABUTTERS LIST

This information is needed so that an official abutters list as required by MA General Law may be created and used in notifying abutters. You, as applicant, are responsible for picking up and paying for the certified abutters list from the assessor's office (city hall, room #109).

SUBJECT PROPERTY	
MAP #	133
LOT(S)#	62, 10, 12
ADDRESS: Samuel Barnett Boulevard, Right Of Way	
OWNER INFORMATION	
NAME: GNBIF/Polaroid LLC, Penn Central Co	
MAILING ADDRESS: 1213 Purchase Street, New Bedford, MA 02740 500 Water Street, Jacksonville, FL 32202	
APPLICANT/CONTACT PERSON INFORMATION	
NAME (IF DIFFERENT): Eileen Piskura	
MAILING ADDRESS (IF DIFFERENT): 4 Technology Drive Suite 110 Westborough, MA 0158	
TELEPHONE #	508-270-6505
EMAIL ADDRESS:	episkura@kleinfelder.com
REASON FOR THIS REQUEST: <i>Check appropriate</i>	
<input type="checkbox"/>	ZONING BOARD OF APPEALS APPLICATION
<input type="checkbox"/>	PLANNING BOARD APPLICATION
<input checked="" type="checkbox"/>	CONSERVATION COMMISSION APPLICATION
<input type="checkbox"/>	LICENSING BOARD APPLICATION
<input type="checkbox"/>	OTHER (<i>Please explain</i>):

Once obtained, the Certified List of Abutters must be attached to this Certification Letter.
 Submit this form to the Department of City Planning, Room 303 in City Hall, 133 William Street, or Email to
 Angela.Goncalves@newbedford-ma.gov. The applicant is responsible for picking up and paying for the certified abutters list from the
 Assessor's Office (city hall, room #109).

Official Use Only:

As Assistant City Assessor to the City of New Bedford's Board of Assessors, I do hereby certify that the names and addresses as identified on the attached "abutters list" are duly recorded and appear on the most recent tax.

Judith M. Serdahl	<i>Judith M Serdahl</i>	9/19/2022
Printed Name	Signature	Date

Amount Due	\$7.00
Date Paid	9/16/2022
Confirmation Number	Check- 1403

CITY OF NEW BEDFORD

Schedule of Departmental Payments to Treasurer
Single Charge Code

Department/Contact: ASSESSORS
GL String: 01411160-439020
Treasury: TW05-101009

Date: 9/15/2022

Charge Code: ASSFEE

From Whom	Source (cash, check, etc)	Amount	Total
DEPARTMENTAL RECEIPT	CC	\$ 7.00	
ABUTTERS LIST	check - 1403		
133-62,10,12			
Samuel Barnett Blvd, Right Of Way			
Eileen Piskura			
		\$ 7.00	

To the City Treasurer:

The above is a detailed list of revenue collected by me, amounting in the aggregate of

_____ Dollars

Receipt# 4077699

Signature: 

Title: PRINCIPAL CLERK

CITY OF NEW BEDFORD

Schedule of Departmental Payments to Treasurer
Single Charge Code

Department/Contact: ASSESSORS
GL String: 01411160-439020
Treasury: TW05-101009

Date: 9/15/2022

Charge Code: ASSFEE

From Whom	Source (cash, check, etc)	Amount	Total
DEPARTMENTAL RECEIPT	CC	\$ 7.00	
ABUTTERS LIST	CHECK - 1403		
133-62,10,12			
Samuel Barnett Blvd, Right Of Way			
Eileen Piskura			
		\$ 7.00	

To the Departmental Officer making the Payment

Received in Treasurer's Office _____ the sum of

_____ Dollars

for collections, as per schedule of this date, filed in my office

City Treasurer

Receipt# 4077699

By _____

September 15, 2022

Dear Applicant,

Please find below the List of Abutters within 100 feet of the property known as Samuel Barnett Blvd, Right of Way (Map: 133, Lot: 62,10,12). The current ownership listed herein must be checked and verified by the City of New Bedford Assessor's Office. Following said verification, the list shall be considered a Certified List of Abutters.

Please note that multiple listed properties with identical owner name and mailing address shall be considered duplicates and shall require only 1 mailing. Additionally, City of New Bedford-Owned properties shall not require mailed notice.

<u>Parcel</u>	<u>Location</u>	<u>Owner and Mailing Address</u>
133-2	ES JOHN VERTENTE BLVD	COMMONWEALTH OF MASSACHUSETTS, 251 CAUSEWAY STREET BOSTON, MA 02114
133-7	960 FLAHERTY DR	AFC CABLE SYSTEMS INC, 260 DUCHAINE BOULEVARD NEW BEDFORD, MA 02745
132-57	RIGHT OF WAY	PENN CENTRAL CO, CONSOLIDATED RAIL CORP 500 WATER STREET DEPT J910 JACKSONVILLE, FL 32202
133-45	50 SAMUEL BARNETT BLVD	C P BOURG INC, 50 SAMUEL BARNET BLV NEW BEDFORD, MA 02745
132-14	200 WELBY RD	WELBY ROAD LLC, 71 MAPLE STREET MANSFIELD, MA 02048
134-455	107 DUCHAINE BLVD	CITY OF NEW BEDFORD, 133 WILLIAM STREET NEW BEDFORD, MA 02740
133-62	SS SAMUEL BARNETT BLVD	GNBIF/POLAROID LLC, C/O CORPORATE REAL ESTATE 1213 PURCHASE STREET NEW BEDFORD, MA 02740
133-35	WS RAILROAD	CITY OF NEW BEDFORD, INTERCEPTING SEWER 131 WILLIAM ST NEW BEDFORD, MA 02740
133-40	ES JOHN VERTENTE BLVD	CITY OF NEW BEDFORD, INTERCEPTING SEWER 131 WILLIAM ST NEW BEDFORD, MA 02740
133-12	R ES SAMUEL BARNETT BLVD	GREATER NEW BEDFORD, INDUSTRIAL FOUNDATION 1213 PURCHASE STREET UNIT 2 NEW BEDFORD, MA 02740
133-10	RIGHT OF WAY	PENN CENTRAL CO, CONSOLIDATED RAIL CORP 500 WATER STREET DEPT J910 JACKSONVILLE, FL 32202
133-50	30 SAMUEL BARNETT BLVD	IMTRA CORPORATION, 30 SAMUEL BARNET BLVD NEW BEDFORD, MA 02745
133-37	64 JOHN VERTENTE BLVD	H & M DARTMOUTH REALTY LLC, 861 PINE HILL DRIVE NEW BEDFORD, MA 02745

September 15, 2022
 Dear Applicant,

Please find below the List of Abutters within 100 feet of the property known as Samuel Barnett Blvd, Right of Way (Map: 133, Lot: 62,10,12). The current ownership listed herein must be checked and verified by the City of New Bedford Assessor's Office. Following said verification, the list shall be considered a Certified List of Abutters.

Please note that multiple listed properties with identical owner name and mailing address shall be considered duplicates and shall require only 1 mailing. Additionally, City of New Bedford-Owned properties shall not require mailed notice.

Parcel	Location	Owner and Mailing Address
133-21	127 127R DUCHAINE BLVD	MILHENCH LLC 127-127 D DUCHAINE BLVD NEW BEDFORD, MA 02745
133-63	NS SAMUEL BARNETT BLVD	H & P INVESTMENTS, LLC, 1942 BROADWAY STREET STE 314 C Boulder, CO 80302
135-8	RIGHT OF WAY	PENN CENTRAL CO, CONSOLIDATED RAIL CORP 500 WATER STREET DEPT J910 JACKSONVILLE, FL 32202
134-456	R WS DUCHAINE BLVD	SM REAL ESTATE LLC, 401 INDUSTRY ROAD - SUITE 100 LOUISVILLE, KY 40208
134-458	R WS PHILLIPS RD	SM REAL ESTATE LLC, 401 INDUSTRY ROAD - SUITE 100 LOUISVILLE, KY 40208

DARTMOUTH



MASSACHUSETTS

OFFICE OF BOARD OF ASSESSORS
400 SLOCUM ROAD
DARTMOUTH, MA 02747-0985

ADMINISTRATOR OF ASSESSING
RICHARD GONSALVES
TEL: 508-910-1809 * FAX: 508 -910-1867

CERTIFIED ABUTTER'S LIST

I, Richard Gonsalves, Assessor for the Town of Dartmouth, certify that the attached list complies with M.G.L. Chapter 40A, Section 11 on this 28th day of September, 2022.

Subject parcel: Flaherty Drive
of abutters certified: 4 Abutters \$25.00

Shown on Map 83

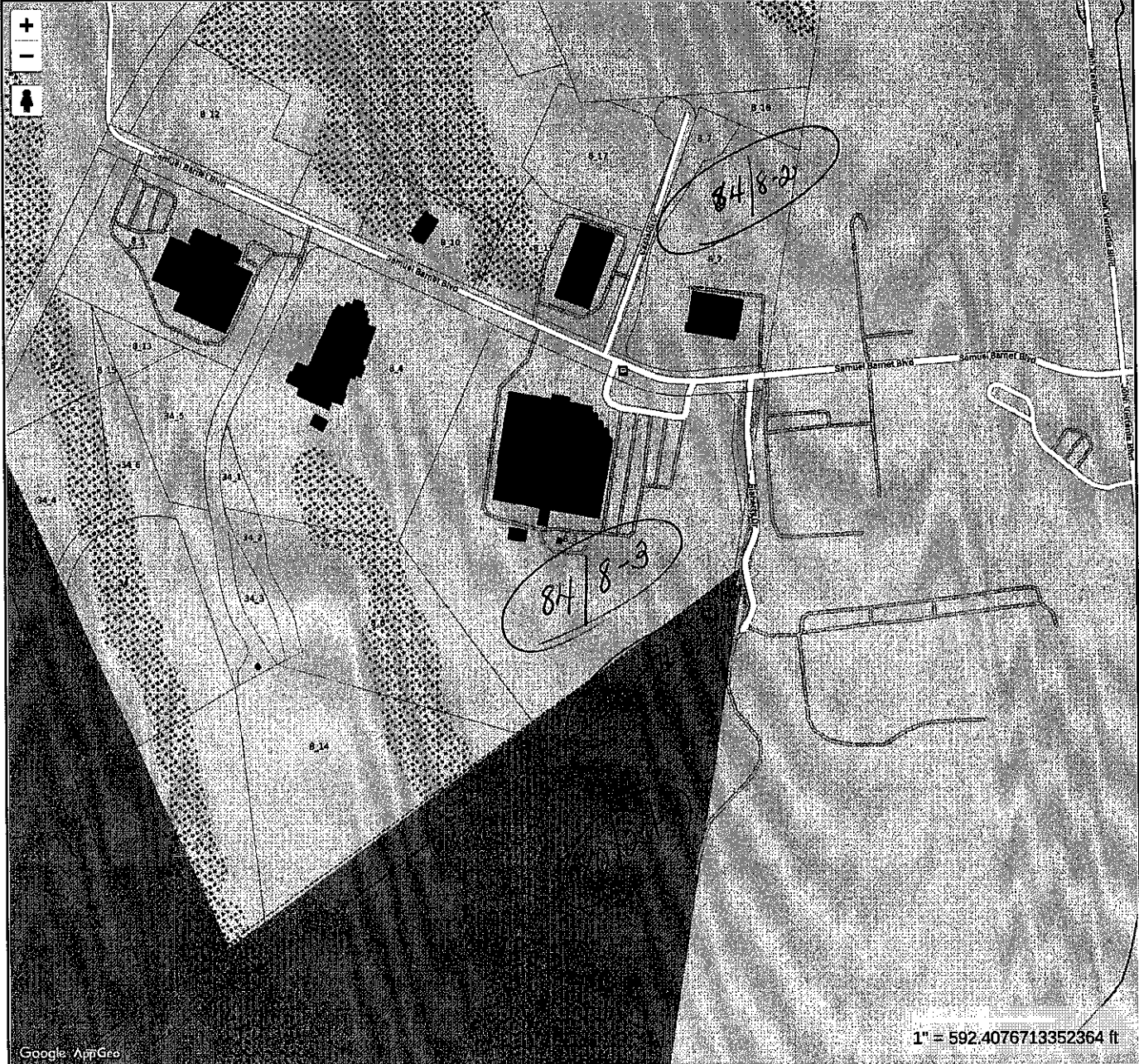

**MAP FOR REFERENCE ONLY
NOT A LEGAL DOCUMENT**

Town of Dartmouth, MA makes no claims and no warranties, expressed or implied, concerning the validity or accuracy of the GIS data presented on this map.

Geometry updated 1/1/2018
Data updated 12/1/2021

Print map scale is approximate. Critical layout or measurement activities should not be done using this resource.

84/8-2
G E C Durham Industries Inc.
255 Samuel Barnet Blvd
N Dartmouth, MA 02747

84/8-3
Acushnet Company
Attn: Tax Department
333 Bridge Street
P O Box 965
Fairhaven, MA 02719-0965

84/8-14
Consolidated Edison Development
100 Summit Lake Dr Ste 410
Valhalla, NY 10595

80/24
Massachusetts Commonwealth of
(Dept of Natural Resources)
100 Cambridge St
Boston, MA 02114

SENDER: COMPLETE THIS SECTION

- Complete items 1, 2, and 3.
- Print your name and address on the reverse so that we can return the card to you.
- Attach this card to the back of the mailpiece, or on the front if space permits.

1. Article Addressed to:

GNBIF/Polaroid LLC, C/O Corporate Real Estate
1213 Purchase St
New Bedford, MA 02740



9590 9402 3206 7166 5347 60

2. Article Number (Transfer from service label)

7017 1450 0001 3379 0783

PS Form 3811, July 2015 PSN 7530-02-000-9053

COMPLETE THIS SECTION ON DELIVERY

A. Signature Agent Addressee

X *Nancy DeWalt*

B. Received by (Printed Name) C. Date of Delivery

Nancy DeWalt D. Is delivery address different from item 1? Yes No
If YES, enter delivery address below:

3. Service Type
- | | |
|--|---|
| <input type="checkbox"/> Adult Signature | <input type="checkbox"/> Priority Mail Express® |
| <input type="checkbox"/> Adult Signature Restricted Delivery | <input type="checkbox"/> Registered Mail™ |
| <input type="checkbox"/> Certified Mail® | <input type="checkbox"/> Registered Mail Restricted Delivery |
| <input type="checkbox"/> Certified Mail Restricted Delivery | <input type="checkbox"/> Return Receipt for Merchandise |
| <input type="checkbox"/> Collect on Delivery | <input type="checkbox"/> Signature Confirmation™ |
| <input type="checkbox"/> Collect on Delivery Restricted Delivery | <input type="checkbox"/> Signature Confirmation Restricted Delivery |
| <input type="checkbox"/> Insured Mail | |
| <input type="checkbox"/> Insured Mail Restricted Delivery (00) | |

Domestic Return Receipt

SENDER: COMPLETE THIS SECTION

- Complete items 1, 2, and 3.
- Print your name and address on the reverse so that we can return the card to you.
- Attach this card to the back of the mailpiece, or on the front if space permits.

1. Article Addressed to:

H&M Dartmouth Realty LLC
861 Pine Hill Dr
New Bedford MA, 02745



9590 9402 3206 7166 5349 68

2. Article Number (Transfer from service label)

7017 1450 0001 3379 0684

PS Form 3811, July 2015 PSN 7530-02-000-9053

COMPLETE THIS SECTION ON DELIVERY

A. Signature Agent Addressee

Horacio Rojas

B. Received by (Printed Name) C. Date of Delivery

HORACIO ROJAS D. Is delivery address different from item 1? Yes No
If YES, enter delivery address below:

3. Service Type
- | | |
|--|---|
| <input type="checkbox"/> Adult Signature | <input type="checkbox"/> Priority Mail Express® |
| <input type="checkbox"/> Adult Signature Restricted Delivery | <input type="checkbox"/> Registered Mail™ |
| <input type="checkbox"/> Certified Mail® | <input type="checkbox"/> Registered Mail Restricted Delivery |
| <input type="checkbox"/> Certified Mail Restricted Delivery | <input type="checkbox"/> Return Receipt for Merchandise |
| <input type="checkbox"/> Collect on Delivery | <input type="checkbox"/> Signature Confirmation™ |
| <input type="checkbox"/> Collect on Delivery Restricted Delivery | <input type="checkbox"/> Signature Confirmation Restricted Delivery |
| <input type="checkbox"/> Insured Mail | |
| <input type="checkbox"/> Insured Mail Restricted Delivery (00) | |

Domestic Return Receipt

SENDER: COMPLETE THIS SECTION

- Complete items 1, 2, and 3.
- Print your name and address on the reverse so that we can return the card to you.
- Attach this card to the back of the mailpiece, or on the front if space permits.

Article Addressed to:

GEC Durham Industries Inc
 255 Samuel Barnet Blvd
 N Dartmouth, MA 02747
New Bedford 02745



9590 9402 6559 1028 6844 88

Article Number (Transfer from service label)

7017 1450 0001 3379 0615

COMPLETE THIS SECTION ON DELIVERY

A. Signature

X *[Handwritten Signature]*

- Agent
- Addressee

B. Received by (Printed Name)

C. Date of Delivery

- D. Is delivery address different from item 1? Yes
- or delivery address below: No

- Adult Signature
- Adult Signature Restricted Delivery
- Certified Mail®
- Certified Mail Restricted Delivery
- Collect on Delivery
- Collect on Delivery Restricted Delivery

- Priority Mail Express®
- Registered Mail™
- Registered Mail Restricted Delivery
- Signature Confirmation™
- Signature Confirmation Restricted Delivery

Mail
 Mail Restricted Delivery
 0)